

ISOMAG

The friendly magmeter

OPERATING AND INSTALLATION MANUAL

CONVERTER

ML 210

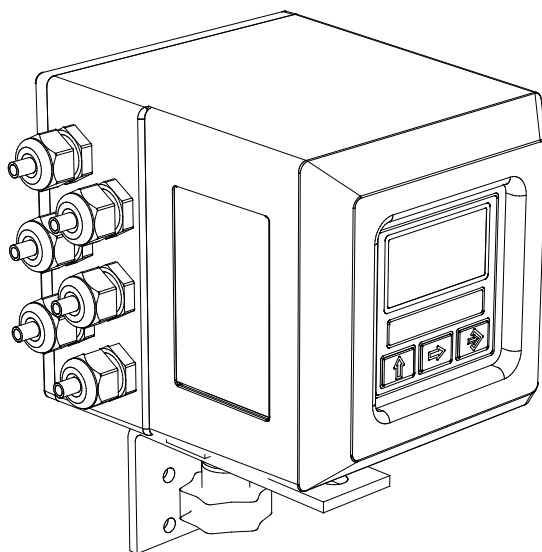

CE

ISOIL 
INDUSTRIA
The solutions that count

Release number: 210_EN_IS_R8_3_9X – The last three digits of file name identify the software version which the manual refers to; it is visualized at the instrument start up, or by specific function on DIAGNOSTIC menu.

INDEX

Introduction	3
Safety informations	3
Safety conventions	4
Technical characteristics	5
Electric characteristics	5
Environmental use conditions	5
Ambient temperature	5
Data plate	5
Overall dimensions	6
Electrical connections	7
Grounding instructions	7
Converter power supply	7
Compact/separate version M1 terminal block	8
Panel version M1 terminal block	8
Converter to sensor electrical connections	9
Optional modules	10
Inputs/outputs	12
Digital input	12
Input operation stage (generic functions)	13
Operation stage on input 1 or 2 (batch function)	14
Operation stage on input 1 and 2 (batch function)	15
Output wirings	16
Converter access	17
Flags and led interpretation	17
Keyboard	18
Blind version	18
Start-up visualization pages	19
Flow rate visualization	20
Access codes	21
Quick start menu	22
Access to the configuration menu	23
Examples	24
Programming functions	26
Functions description	29
Batch function configuration	38
Alarm messages	40
Appendix: Display rotation procedure	41
Service: return form for instrument repair or calibration	45
Conformity declaration	47
Addresses	48

INTRODUCTION

These operating instructions and description of device functions are provided for the scope of supply. They could be modified without prior notice. The improper use, possible tampering of the instrument or parts of it and substitutions of any components not original, makes the warranty to decay automatically.

The converter is to be used only to be coupled with a sensor to realize a measuring device, flow meter, that is to be used for measuring the flow of conductive liquids in closed pipes with conductivity greater than $5\mu\text{S}/\text{cm}$.

The converter could be coupled directly on the sensor (compact version) or coupled to the sensor by cable supplied with it (remote version).

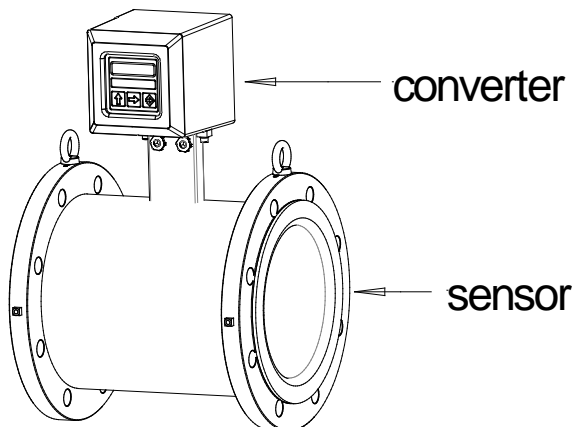

It is forbidden the reproduction of the present manual and of possible software supplied.

SAFETY INFORMATIONS

Any use other than described here affects the protection provided by the manufacturer and compromises the safety of people and the entire measuring system and is, therefore, not permitted.

The manufacturer is not liable for damaged caused by improper or non-designated use.

- 1) Transport the measuring device to the measuring point in the original packaging. Do not remove covers or caps until immediately before installation. In case of cartons package it is possible to place one above the other but no more than three cartons. In case of wooden package do not place one above the other.
- 2) Disposal of this product or parts of it must be carried out according to the local public or private waste collection service.
- 3) The converter must only be installed, connected and maintained by qualified and authorized specialists (e.g. electrical technicians) in full compliance with the instructions in these Operating Instructions, the applicable norms, legal regulations and certificates (depending on the application).
- 4) The specialists must have read and understood these Operating Instructions and must follow the instructions they contain. If you are unclear on anything in these Operating Instructions, you must call the ISOIL service. The Operating Instructions provide detailed information on the converter.

- 5) The converter should only be installed after have verified technical data provided in this operating instructions and on the data plate.
- 6) Specialists must be carefully during installation and use personal protective equipment as provided by their security plan about risk assessment.
- 7) Never mount or wire the converter while it is connected to the power supply and avoid any liquid contact with the instrument internal components. To connect remove the terminals from the terminal block.
- 8) Before connecting the power supply check the safety equipment.
- 9) Repairs may only be performed if a genuine spare parts kit is available and this repair work is expressly permitted.
- 10) For the cleaning of the device use only a damp cloth, and for the maintenance/repairs contact the service center (for details see the last page).
- 11) To deliver the converter back to the service workshop use and fill the form in the last pages of this operating instructions.

Before starting up the equipment please verify the following:

- Power supply voltage must correspond to that specified on the data plate
- Electric connections must be completed as described
- Ground (earth) connections must be completed as specified

Verify periodically (every 3-4 months):

- The power supply cables integrity, wiring and other connected electrical parts
- The converter housing integrity
- The suitable tightness of the sealing elements
- The front panel integrity (display and keyboard)
- The mechanical fixing of the converter to the pipe or wall stand.

SAFETY CONVENTIONS

DANGER



Warning indicates an action or procedure which, if not performed correctly, can result in injury or a safety hazard. Comply strictly with the instructions and proceed with care.

WARNING



Caution indicates an action or procedure which, if not performed correctly, can result in incorrect operation or destruction of the device. Comply strictly with the instructions.

NOTES



Note indicates an action or procedure which, if not performed correctly, can have an indirect effect on operation or trigger an unexpected response on the part of the device.

TECHNICAL CHARACTERISTICS



ELECTRIC CHARACTERISTICS

Instrument classification: class I, IP67 for compact/separate version, IP54 for panel version (IP65 with optional transparent frontal cover), installation category II, rated pollution degree 2.

Power supply versions	Power supply voltage	Power supply frequency	Pmax
HV	100-240V~	44-66Hz	25VA
LV	18-45V~		
		18-45V---	//
LLV	10-35V---		

- Voltage changes must not exceed $\pm 10\%$ of the nominal one.
- All instrument versions can be equipped with all power supply versions.
- Input/output are insulated up to 500V
- The output 4-20 mA (optional) and the output 24V--- are electrically connected.



ENVIRONMENTAL USE CONDITIONS

- The instrument can be installed inside or outside buildings
- Altitude: from -200m to 2000m (from -656 to 5602 feet)
- Humidity range: 0-100% (IP 67), 0-90% without condensation (IP54) for panel version

AMBIENT TEMPERATURE

	Min. *	Max
°C	-20	60
°F	-4	140

If the converter is supplied in compact version to the sensor, consider the ambient temperatures more restrictive, otherwise refer to the respective manuals.

* For discontinuous use, a thermostat heat source installation may be necessary.

Data plate

On the data plate there is some technical information:

- **MODEL:** Converter Model
- **S/N:** Serial Number of the converter
- **P.S.:** Power Supply
- **POWER:** Maximum power consumption
- **Hz:** Frequency (AC)
- **T:** Operating temperature
- **IP:** Protection grade
- **COUPLING:** Serial number of sensor coupled
- **ITEM:** free for user

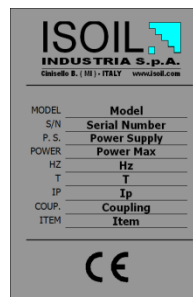

OVERALL DIMENSIONS

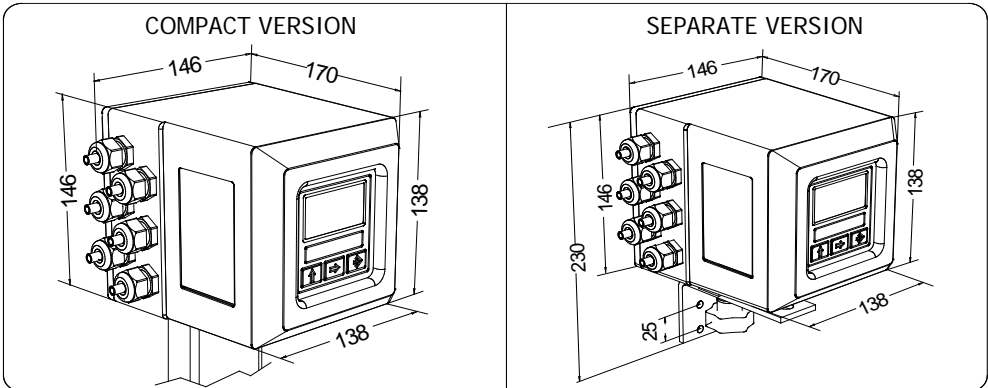

WEIGHT

	Compact	Separate
INOX AISI 304	3kg	3.5kg
Alluminum	2.5kg	3kg

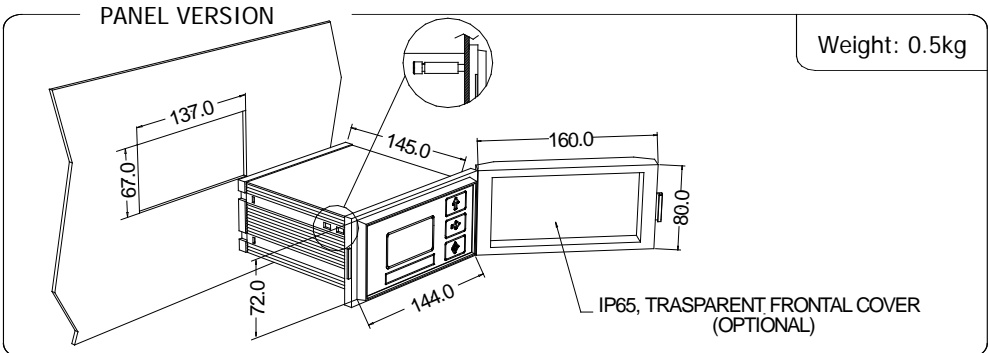

TORQUES

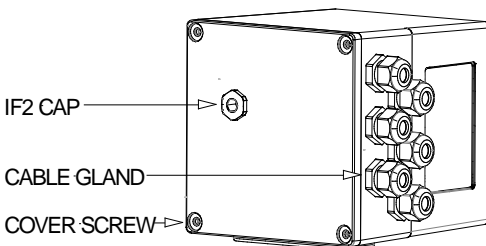

To guarantee the compact/separate housing's IP degree the following torques are required:

- ❑ cover screws: 1.5Nm
- ❑ cable glands: 4Nm (in reference conditions)
- ❑ IF2 cap: 4Nm

ELECTRICAL CONNECTIONS



GROUNDING INSTRUCTIONS

ALWAYS ensure that the converter and the sensor are grounded (earthed) correctly. The grounding of the sensor and converter ensures that the equipment and liquid are equipotential.



CONVERTER POWER SUPPLY

Compact/separate version

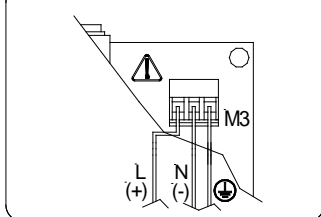

Panel version

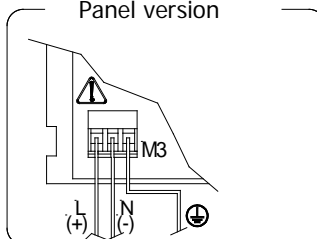

- ❑ Before connecting the power supply, verify that the mains voltage are within the limits indicated on data plate.
- ❑ For the connections use only approved conductors, with fire-proof properties, whose section varies from 0.25mm^2 to 2.50mm^2 , based on distance/power; as well fix the power supply wires with a additional fastening system located close to the terminal.
- ❑ The power supply line must be equipped with an external protection for overload current (fuse or automatic line breaker).
- ❑ Provide nearness the converter a circuit breaker easily accessible for the operator and clearly identified; whose symbols must conform to the electrical safety and local electrical requirements.
- ❑ Ensure that the component complies with the requirements of the standard for electrical safety distance.
- ❑ Check the materials chemical compatibility used in the connection security systems in order to minimize the electrochemical corrosion.
- ❑ The sensor, hardwired inputs and outputs are connected to the converter through a terminal blocks located inside the converter.
- ❑ To locate the compact/separate version terminal block loosen the 4 screws on the back cover. When the front cover is lifted, the terminal block is visible. The terminal block is the hardwire connection of the converter to external equipment, including the sensor.

The following pages give informations on the terminal block numbering, and the respective connecting of the sensor cables, and inputs/outputs.

COMPACT/SEPARATE VERSION M1 TERMINAL BLOCK

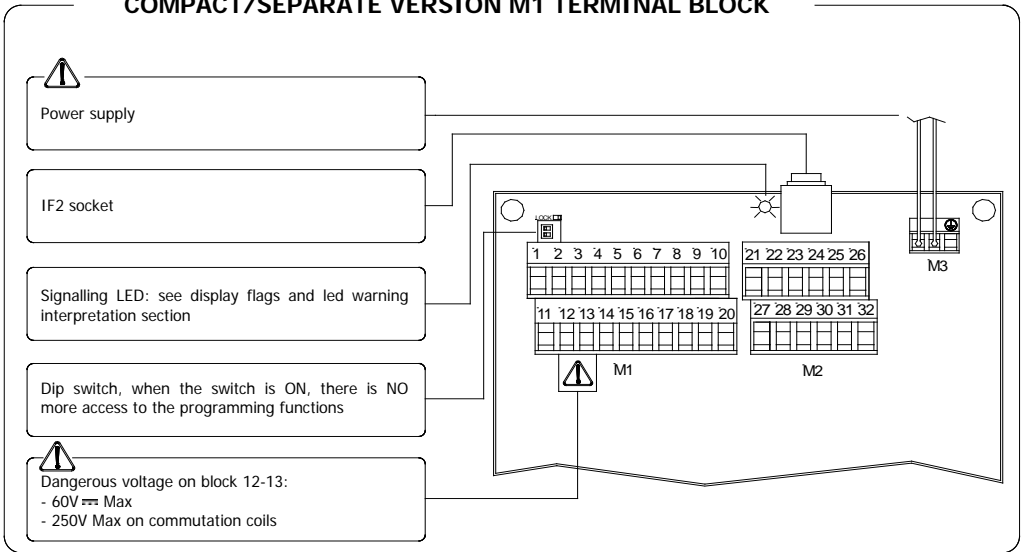

PANEL VERSION M1 TERMINAL BLOCK

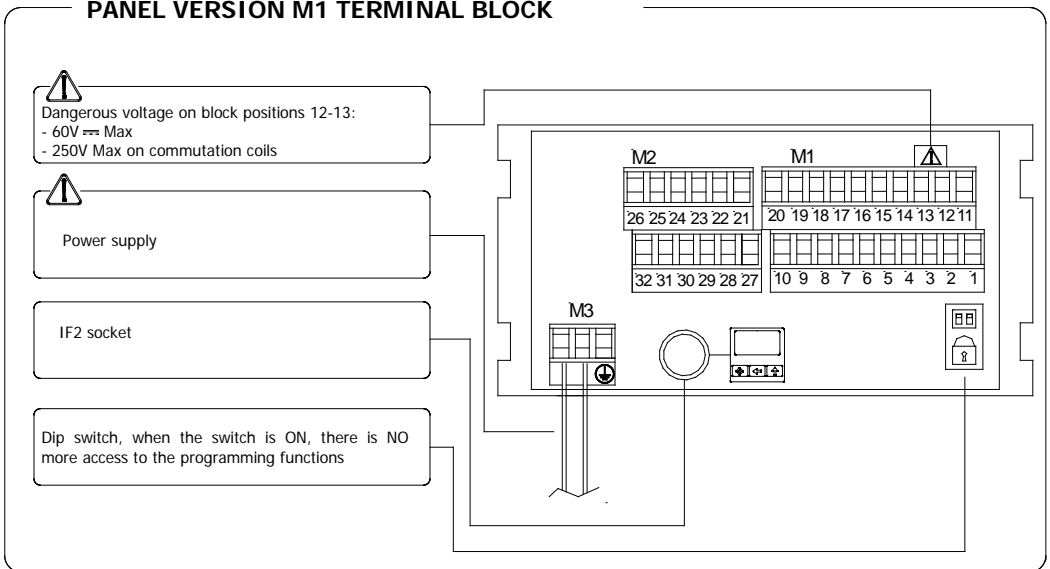

CONVERTER TO SENSOR ELECTRICAL CONNECTIONS

SEPARATE VERSION

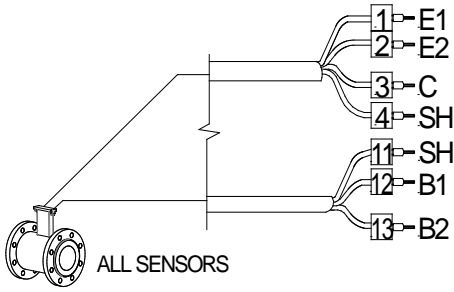

Sudden movements of the electrodes cable, can cause noise on measure.
Max cables length: 20m.

TERMINAL BLOCK M1

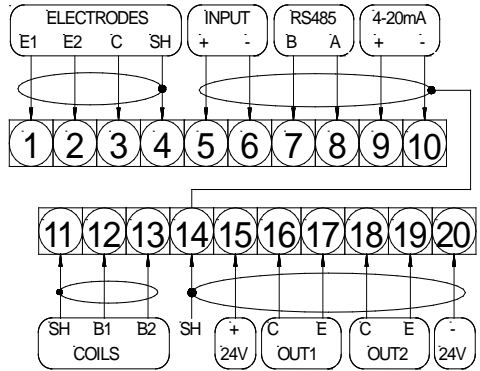

SENSOR WITH PREAMPLIFIER

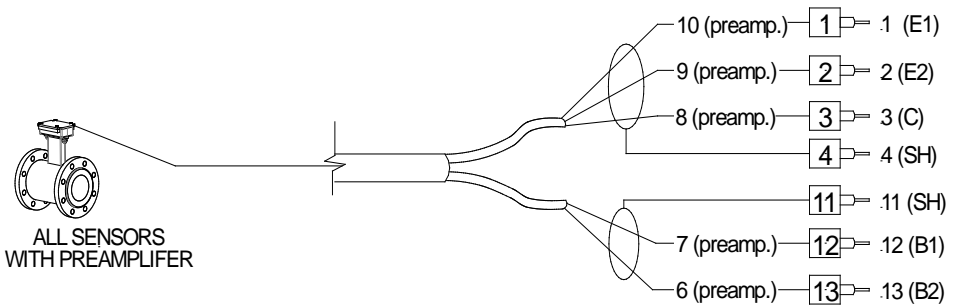
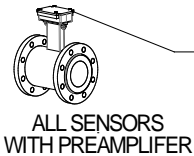

Max cable length: 500m

OPTIONAL RELÈ MODULES

- ❑ **ME205:** 2 relay outputs with 1 NO contact + 1 NC contact each, 2A 60V~, 60W/125VA
- ❑ **ME207:** 2 relay outputs with 1 NO contact + 1 NC contact each, 2A 250V~, 60W/125VA

LEGEND

- ❑ **SH:** Cable shield, electrically connected to ground and to the casing
- ❑ **C:** Relay – common
- ❑ **NC:** Normally closed contact
- ❑ **NO:** Normally open contact

Terminal block on compact/separate version

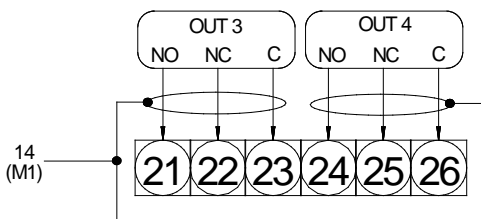

M2 position on separate/compact version

Terminal block on panel version

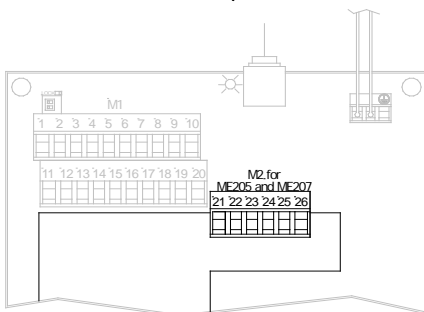
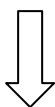
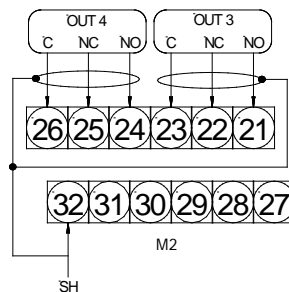

NOTE: On panel version the terminal block **M2** is the same than other modules.

INPUTS/OUTPUTS

DIGITAL INPUT

External power supply

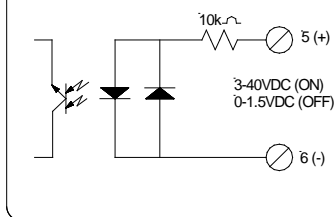

Internal power supply

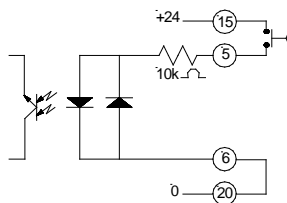

The functions referring to the inputs could be divided in three groups:

- 1) only assignable functions to the input 1
- 2) functions that act directly on the inputs independently from the select input
- 3) only assignable functions to the input 1 and only to the input 2 which interact between them

For details see the following pages.

Remember that the activation of any functions of batch automatically disable the other. The list of such functions is suitable in the table of the batch function configuration section.

OPERATION ON INPUT ON/OFF

INPUT OPERATION STAGE (GENERIC FUNCTIONS)

Auto-calibration

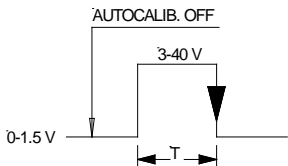

$T_{min} < T < 1 \text{ sec.} = \text{autocalibration}$
$T > 1 \text{ sec.} = \text{Auto zero}$
Necessary conditions for enabling the function
POS. 5.7 ENABLED (Autozero calibration external command)
POS. 5.9 DISABLED (batch on input 1)
POS. 5.10 DISABLED (batch functions assign to input 2 (optional))

Reset totalizers

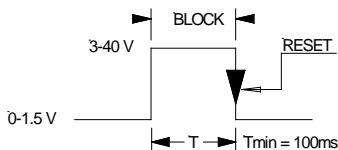

Necessary conditions for enabling the function
POS. 5.1 to 5.4 ENABLED (partial positive or reverse flow totalizers reset enable).
N.B.: This function is even assignable to the input 2

Block totalizers

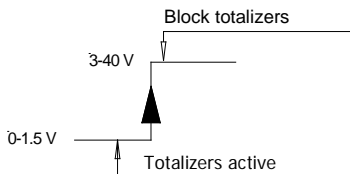

Necessary conditions for enabling the function
POS. 5.6 ENABLED (totalizers counting lock command)
POS. 12.5 DISABLED (auto-batch)
POS. 12.7 DISABLED (batch consent)

Range change

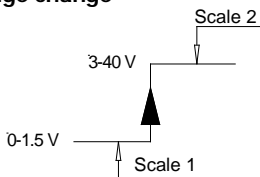

Necessary conditions for enabling the function
POS. 5.8 ENABLED (range change)
POS. 5.9 DISABLED (batch on input 1)
POS. 5.10 DISABLED (batch functions assign to input 2 (optional))
POS. 6.1-4 DISABLED (end-batch functions assign to output 2)

Speed rate

T_{min}

10Hz	220ms
20Hz	110ms
50Hz	45ms
80Hz	30ms
150Hz	15ms



ATTENTION: time T must be \geq to T_{min}



Note: THE FUNCTIONS ABOVE ARE ENABLED ONLY ON INPUT 1

OPERATION STAGE ON INPUT 1 OR 2 (BATCH FUNCTION)

Start batch from remote input

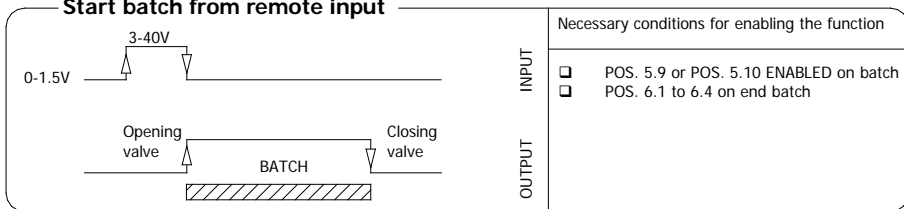

Start batch from consent (remote)

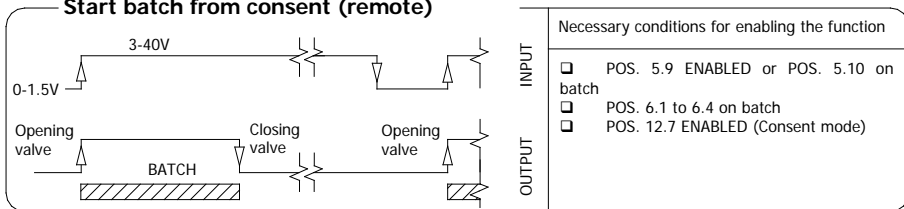

Start batch from remote input with auto-batch enabled

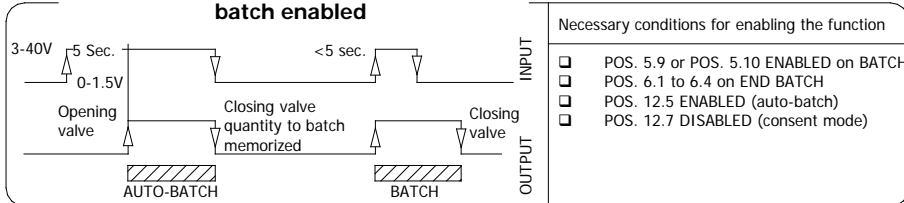

Start batch from remote input with automatic selection of formula 00/03

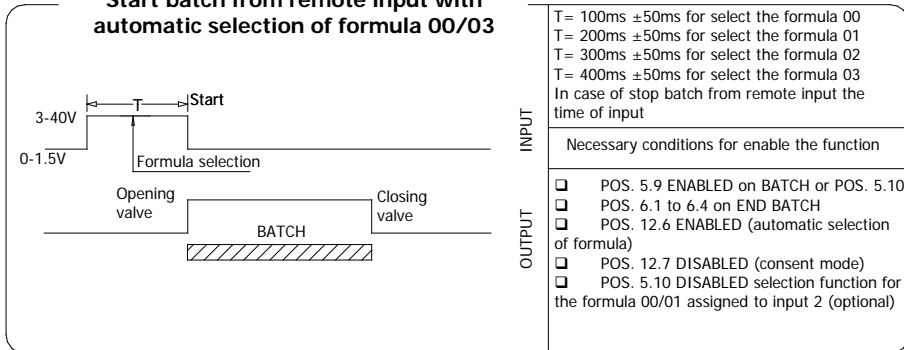

Start batch from remote input 1 reset p+ enabled on remote input 1

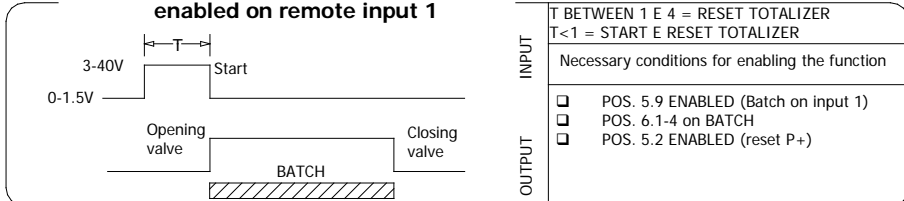

N.B.: THE ACTIVATION OF BATCH FUNCTIONS ON INPUT 2 PREVENTS THE ACTIVATION OF BATCH FUNCTIONS ON INPUT 1

OPERATION STAGE ON INPUT 1 AND 2 (BATCH FUNCTION)

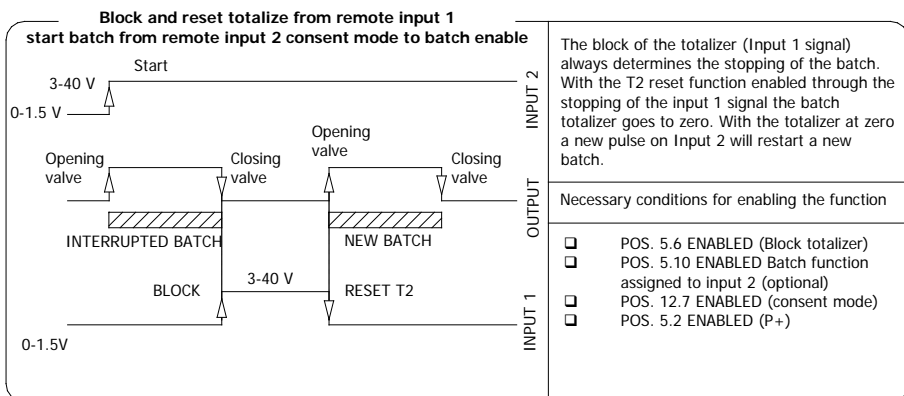
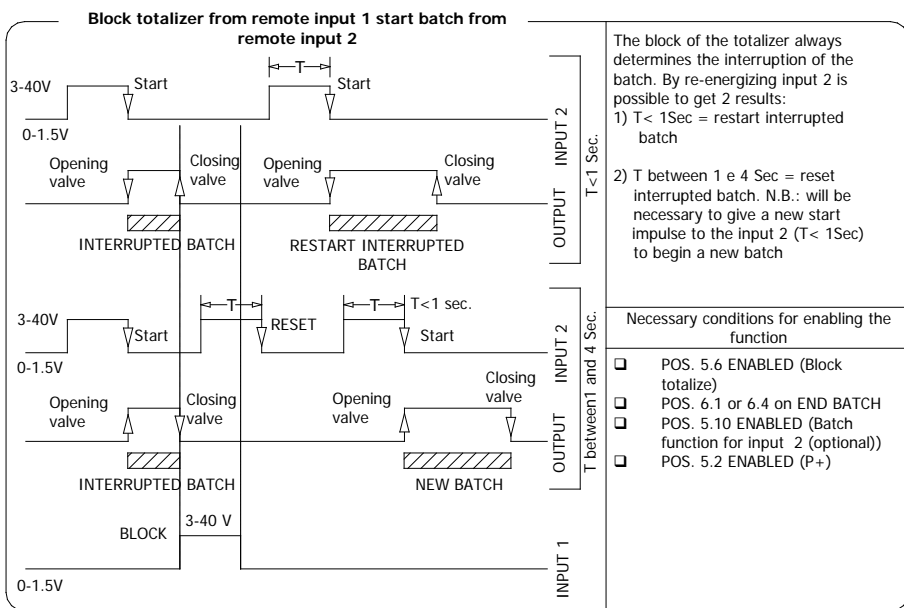
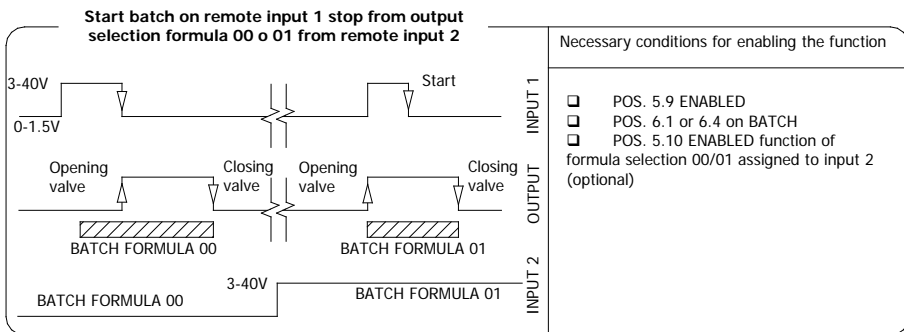

OUTPUT WIRINGS

Output on/off 1250Hz

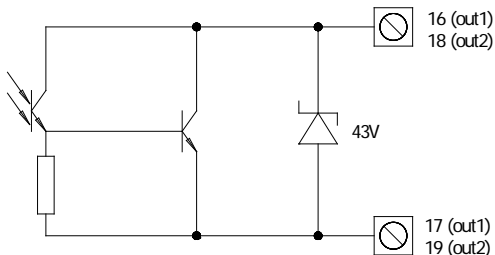

- ❑ Opto-insulated output with collector and emitter terminals floating and freely connectable
- ❑ Maximum switching voltage: 40V
- ❑ Maximum switching current: 100mA
- ❑ Maximum saturation voltage between collector and emitter @100mA: 1.2V
- ❑ Maximum switching frequency (load on the collector or emitter, $R_L=470\Omega$, $V_{OUT}=24V$): 1250Hz
- ❑ Maximum reverse current bearable on the input during and accidental polarity reversion (VEC): 100mA
- ❑ Insulation from other secondary circuits: 500V



OUTPUT 1/2 standard - OUTPUT 3/4 with modules

Output on/off 12500 Hz

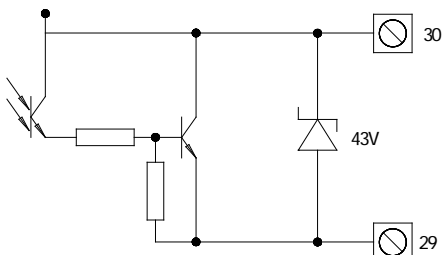

- ❑ Opto-insulated output with collector and emitter terminals floating and freely connectable. In order to get the maximum speed performances it is necessary to connect the emitter to the common terminal of the outputs (0V), while the load has to be on the collector. This output is internally connected to the power supply source 24V available on the terminal block.
- ❑ Maximum switching voltage: 40V
- ❑ Maximum switching current: 100mA
- ❑ Maximum saturation voltage between collector and emitter 100mA, load on the collector and internal power supply: 0.3V
- ❑ Maximum saturation voltage between collector and emitter 100mA, load on the emitter and internal power supply: 3V
- ❑ Maximum switching frequency, load on the collector and internal power supply: ($R_L=470\Omega$, $V_{OUT}=24V$): 12500Hz
- ❑ Maximum switching frequency, load on the emitter or external power supply: ($R_L=470\Omega$, $V_{OUT}=24V$): 2500Hz
- ❑ Insulation from the other secondary circuits (except 24V and 4-20mA outputs): 500V



Only with ME 201 module

4-20mA output

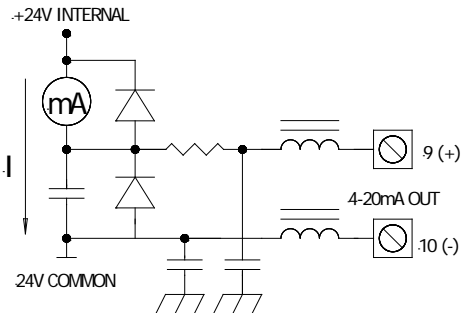

- ❑ Opto-insulated output
- ❑ Maximum load 1000 Ω
- ❑ Maximum voltage without load 27V
- ❑ Refresh frequency equal to the sample frequency of the connected sensor
- ❑ Protected against persistent over voltages up to 30V



The converter detect a loss of load on the 4 to 20mA output; to disable this function set the value "mA val. fault" to 0 (Pos. 4.6)

NOTE: for the inputs and outputs wirings is recommended the use of shielded cables.

CONVERTER ACCESS

FLAGS AND LED INTERPRETATION

FLAGS

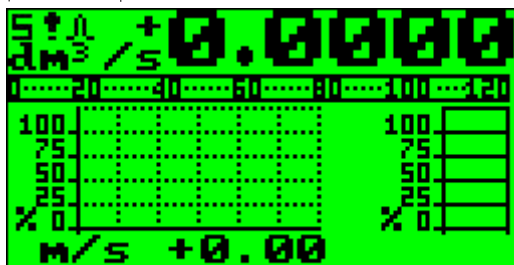

FLAGS INTERPRETATION	
FLAG	DESCRIPTION
↕	Alarm max/min activated
!	- Interruption coils circuit - Segnal error - Empty pipe
C	Calibration running
S	Simulation
	Pulse output saturation (reduce TIME PULSE)

LED

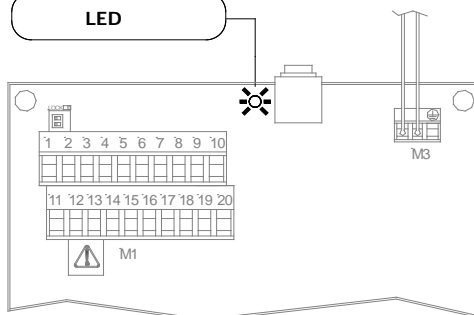

LED INTERPRETATION

PERMANENT LIGHT: initialization

FLASHING LIGHT (1 sec.): normal function

FLASHING LIGHT (<1 sec.): alarm on

The LED signals the real alarm status only if the display visualizes one of the visualization pages

ATTENTION: The LED is not visible in the panel version of the converter

KEYBOARD



SHORT PRESSING (< 1 SECOND):

Increases the numeric figure or the parameter selected by the cursor
Returns to the previous subject on the menu
Batch start/stop (when enabled)

LONG PRESSING (> 1 SECOND):

Decreases the numeric figure or the parameter selected by the cursor.
Proceeds to the next subject on the menu



SHORT PRESSING (< 1 SECOND):

Moves/positions the cursor rightward on the input field
Proceeds to the following subject of the menu
Change the display of the process data

LONG PRESSING (> 1 SECOND):

Moves/positions the cursor leftward on the input field
Returns to the previous subject on the menu



SHORT PRESSING (< 1 SECOND):

Enter /leave the selected function
Enables the main menu for the instrument configuration
Cancels the selected function under progress

LONG PRESSING (> 1 SECOND):

Leaves the current menu
Enables the totalizer reset request (when enabled)
Confirms the selected function

BLIND CONFIGURATION

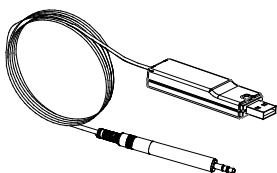

For the converters without keyboard (blind version), the programming is made through ISOCON (cable and software needed).
Being the housing closure dependent by the installer, the IP degree may be compromised, so follow the torques mentioned.

START-UP VISUALIZATION PAGES

The direct exposure of the converter to the solar rays, could damage the liquid crystals display. For the contrast set see pos. 8.3

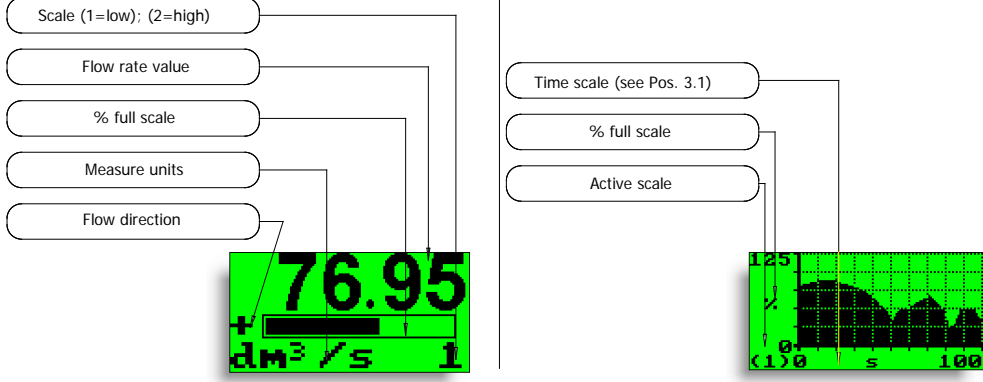
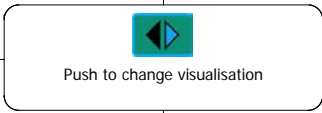
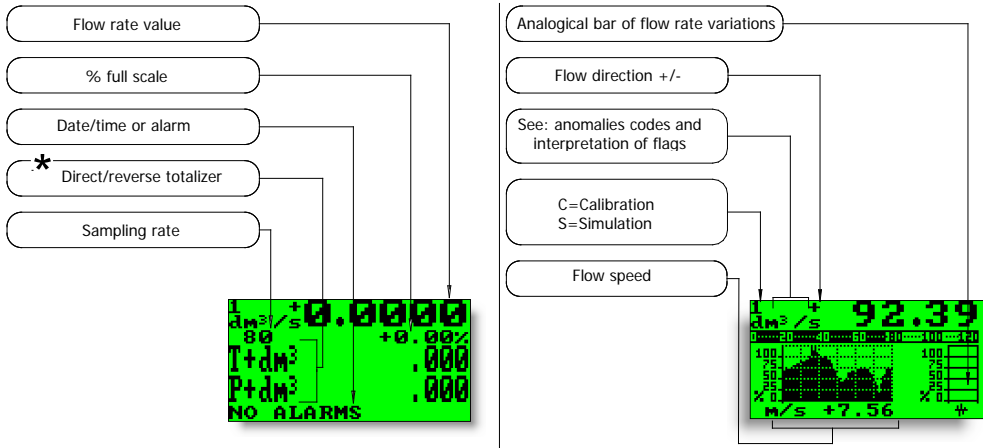

* The maximum digit shown from the totalizer is 999999999 independently from the number of selected decimals. Beyond this value the totalizer are reset.

CONVERTER VISUALIZATION PAGE WITH CURRENCY FUNCTION ENABLE

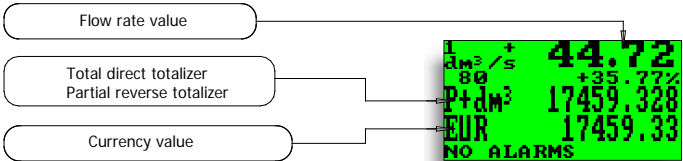

NOTE

The visualization of the pages can be change respect to some functions enabled o disabled (Pos. 8.4÷7÷8 and batch functions)



FLOW RATE VISUALIZATION

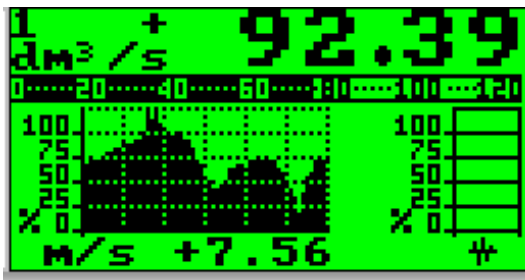

The ML 210 allows to show a 5 digit character display for flow rate units; this mean the maximum flow rate value that can be represented on the display is **99999** (no matter the positioning of the decimal point). The minimum one is **0.0025**.

The representable measure unit depends from sensor flow rate and diameter; the permitted units are those, set the instrument full scale value, allow to be represented with a numerical field which the maximum value do not exceed **99999**.

Example for DN 300:

- Full scale value: 3m/s
- **PERMITTED** measure unit (example): l/s (216.00); m³/h (777.60); m³/s (0.2160)
- **NOT PERMITTED** measure unit (example): l/h (777600)..

ACCESS CODES

Functions in the main menu converter are enabled by the access codes. The information of this manual is related to all the functions available with the L2 level. All higher level functions are reserved for servicing and not available.

Description of the L2 access code

(menu "11 Internal data" pos. 11.1)

- **with code L2 = 00000** (only with this code) you can disable the L2 code request
 - * **with L2 customized** (freely chosen by the user) you can program all the functions up to L2 security level, entering this code whenever you enter the Main menu.
- * **ATTENTION:** take careful note of the customized code you have chosen, there is no way for the user to retrieve or reset it if lost.

Factory preset access codes

The converter is delivered with the default L2 (level 2) access code:

11111

BLOCK DIP-SWITCH

The block dip-switch **disables** the access to the converter's functions.

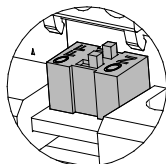

To activate this block move both switch to the ON position

NOTE: with block enabled is possible to view all visualization pages pressing the key 

Factory pre-setting: DIP-SWITCH **OFF**

QUICK START MENU

The user has immediate access to the Quick Start menu when the converter is powered up by pressing the **Enter** key. If access to the quick start menu does not occur, then it has been disabled through function 8.6

```

0-QUICK START
Fs1=dm³/s 500.00
Fs2=dm³/s 500.00
Tot.MU= 1 01.00
Pls1= 1 1.00000
Pls2= 1 1000.00
Tpls1=ms 0032.00
Tpls2=ms 0250.00
Contrast= 6
Language= EN
Batching setup
Regulat.setup
Flow meas.setup
SMART meas.set.
Main menu
  
```

See programming functions section

Automatic parameters optimization (see below)

Access to all functions

The set up functions (batching, regulation, flow and SMART measure) regulate automatically the values of filters for the operation set modifying optimally the parameters related to the function chosen.

To enable one of four types operation press the key **Enter** while the function is highlighted, to confirm the changes press long the **Enter** key.

Filters settings for different S.rate (sensor menu, not user modifiable):

	Batching		Regulation		Flow measure		SMART measure	
	MFSLN	MFFLN	MFSLN	MFFLN	MFSLN	MFFLN	MFSLN	MFFLN
10Hz	0	0	10	0	20	0	100	10
20Hz	0	0	5	0	10	0	50	5
50Hz	0	0	2	0	4	0	20	2
80Hz	0	0	1.3	0	2.5	0	12.5	1.25
150Hz	0	0	0.7	0	1.3	0	6.7	0.67

See the **functions description** section for more details over the filters.

ACCESS TO THE CONFIGURATION MENU

The converter configuration menu can be accessed in two different ways:

- 1) by **ISOCON** interface
- 2) by **keyboard** of converter

ACCESS TO THE CONFIGURATION MENU BY ISOCON INTERFACE

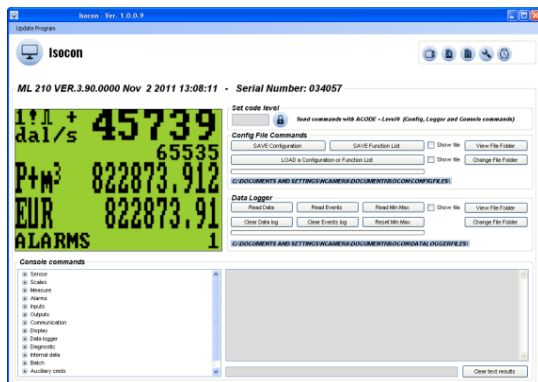

Isocon is a Windows® software that allows to set all the converter functions and personalize the menu (IF2X is required), see suitable manual for details

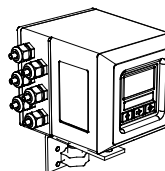

ACCESS TO THE CONFIGURATION MENU BY THE KEYBOARD

Functions can be accessed by the keyboard in two different ways:

- ❑ The **Quick start menu** makes possible to access directly a range of principal functions for setting the scale reading and display characteristics of the sensor. Quick start menu can be enabled by function 8.6 (menu display)

```

0-QUICK START
Fs1=dm³/s 5.0000
Fs2=dm³/s 8.1920
Tot.MU=dm³ 1.000
Iconst=s 0001.0
ND=mm 00032
Simulation= OFF
Contrast= 7
  
```

Factory pre-setting: QUICK START MENU=ON

- ❑ Through the **Main menu** it is possible to access functions with the access code level 2. These control the sensor's monitoring, data processing, input/output as well further display options.

```

MAIN MENU
1-Sensor
2-Scales
3-Measure
4-Alarms
5-Inputs
6-Outputs
7-Communication
  
```

The following example shows how to change the Full scale by Quick Start menu; the second illustrates how to change the function by the Main menu.

EXAMPLE: modifying the full scale value from 4dm³/s to 5dm³/s, from "Quick start menu"

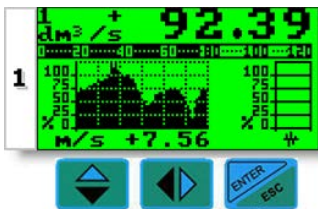

Enter in the "Quick start menu"



Access to the function "Fs1"



Push repeatedly



Change the value



Confirm the new value



Long push



Main page

EXAMPLE: modifying the full scale value from 4dm³/s to 5dm³/s, from "Main Menu" (quick start menu enabled)

1  Enter in the "Quick start menu"

2  **3**  Access to the "Main Menu"

4  **5**  Confirm the keycode

6  X 5 TIMES

7  Access to the "Scale" menu

8  Access to the function "Fs1"

9  Push repeatedly

10  Change the value

11  Confirm the new value

12  Long push

13  Long push

14  Main page

PROGRAMMING FUNCTIONS

(functions with access code < 3, those with symbol "*" see the next section)

Attention: The function in grey colour are visualized on display only with other active functions or with optional modules

```
MAIN MENU
1-Sensor
```

```
1-SENSOR
ND=mm 10000
KA= +01.0000
Sens.type= 014
Ins.position= 1
Ki= 1.0015
Kp= 0.8865
Cable len.=m 000
E.P.detect= ON
E.cleaning= OFF
E.p.thr.= 250
Autozero cal.
```

- 1.1 Insert ND of sensor (0-3000mm)
- 1.2 Sensor calibration data, visualized on sensor's label
- 1.3 Type of sensor: Enter the first two characters of the sensor serial number
- 1.4 Position for insertion sensors: 0=1/8DN, 1=1/2DN, 2=7/8DN
- 1.5 Factory parameters automatically calculated (ONLY for insertion sensors)
- 1.6 Length of the cable connecting the sensor to the converter
- 1.7 Enables the empty pipe detection feature
- 1.8* Electrodes cleaning
- 1.9* Value of empty pipe sensibility detection
- 1.10* Enables the automatic procedure of zero calibration

```
MAIN MENU
1-Sensor
2-Scales
```

```
2-SCALES
Fs1=dm³/s 5.0000
Fs2=dm³/s 8.1920
Tot.MU=dm³ 1.000
Pls1=dm³ 1.00000
Pls2=dm³ 1.00000
Ipls1=ms 0050.00
Ipls2=ms 0050.00
Frg1=Hz 1000.00
Frg2=Hz 1000.00
Mass units= ON
Sg=kg/dm³ 01.0000
```

- 2.1* Full scale value set for range N.1
- 2.2* Full scale value set for range N.2
- 2.3* Unit of measure and number of decimal place
- 2.4* Pulse value on channel 1
- 2.5* Pulse value on channel 2
- 2.6* Duration of the pulse generated on channel 1
- 2.7* Duration of the pulse generated on channel 2
- 2.8 Full scale freq. for channel 1 (0.1Hz-1000.0Hz) (0.1Hz-10000Hz with opt. module)
- 2.9 Full scale freq. for channel 2 (0.1Hz-1000.0Hz) (0.1Hz-10000Hz with opt. module)
- 2.10 Enable/disable the selection of mass units on full scale set
- 2.11 Specific gravity set in kg/dm³

```
MAIN MENU
1-Sensor
2-Scales
3-Measure
```

```
3-MEASURE
AC Filter=s 0.1
M.filter=s 020.0
Cut-off=s 00.7
Autocal.= OFF
Autorange= OFF
E.saving= OFF
12-Batch
```

- 3.1* Main frequency filter
- 3.2* Measure filter
- 3.3 Low flow zero threshold: 0-25% of full scale value
- 3.4 Enable every hour an internal cycle of calibration. Measurement stopped for 8-15 sec.
- 3.5* Automatic change of scale
- 3.6* Energy saving mode

```
MAIN MENU
1-Sensor
2-Scales
3-Measure
4-Alarms
```

```
4-ALARMS
Max thr+=% 000
Max thr-=% 000
Min thr+=% 000
Min thr-=% 000
Hyst.=% 03
mA v.fault=% 000
Hz v.fault=% 125
Timeout=s 00.0
```

- 4.1 Maximum value alarm set for direct flow rate
- 4.2 Maximum value alarm set for reverse flow rate
- 4.3 Minimum value alarm set for direct flow rate
- 4.4 Minimum value alarm set for reverse flow rate
- 4.5 Hysteresis threshold set for the minimum and maximum flow rate alarms
- 4.6* Current output value in case of failure
- 4.7* Frequency output value in case of failure
- 4.8* Batch safety timer

MAIN MENU

```

1-Sensor
2-Scales
3-Measure
4-Alarms
5-Inputs

```

5-INPUTS

```

I+ RESE1= ON
P+ RESE1= ON
I- RESE1= OFF
P- RESE1= ON
Puls. reset= OFF
Count lock= ON
Calibration= OFF
Range change= OFF
Batch= OFF
Inp. 2= OFF

```

- 5.1* Total direct (positive) flow totalizers reset enable
- 5.2* Partial direct (positive) flow totalizers reset enable
- 5.3* Total reverse (negative) flow totalizers reset enable
- 5.4* Partial reverse (negative) flow totalizers reset enable
- 5.5 Reset totalizers of pulse from digital input (see page 13)
- 5.6 Totalizers counting lock command (see page 13)
- 5.7* Autozero calibration external command
- 5.8 Range change external command (see function 3.5)
- 5.9 Batch start/stop external command (see batch functions)
- 5.10* Functions assigned to input 2

4-alarms

5-Inputs

6-Outputs

```

6-OUTPUTS
Out1= #1 IMP+
Out2= SIGN
Out3=
Out4= #2 IMP+
Out mA1=4-22
Out mA2=4-22

```

- 6.1* Output 1 functions
- 6.2* Output 2 functions
- 6.3* Output 3 functions
- 6.4* Output 4 functions
- 6.5* Choice of the function and the range of current output n.1
- 6.6* Choice of the function and the range of current output n.2

6-Outputs

7-COMMUNICATION

```

7-COMMUNICATION
IF2 pr.= DPP
RS232 pr.= DPP
RS485 bps= 19200
RS232 bps= 19200
Printer= OFF
Print batch= OFF
Print data= OFF
Print events= OFF
A.delay=ms 20
Parity= NONE
Address= 000
Rem. addr.= 000
Remote u.conn.

```

- 7.1 Choice of the communication protocol for the IF2 device
- 7.2 Choice of the communication protocol for the RS232 port
- 7.3 Speed of the RS485 output (possible choices: 4800, 9600, 19200, 38400 bps)
- 7.4 Speed of the RS232 output (possible choices: 4800, 9600, 19200, 38400 bps)
- 7.5 Print function enable (optional)
- 7.6 Print of the performed batch
- 7.7 Print of the data process on regular intervals
- 7.8 Print of events
- 7.9 Instrument answer delay
- 7.10 RS485 parity
- 7.11 Address value of converter (range 0 - 255)
- 7.12 Address of a further converter connected like a terminal
- 7.13 Start remote connection to the terminal. Connection interrupted after 10sec. of inactivity

8-DISPLAY

```

Language= EN
D.rate=Hz 1
Contrast= 7
P. totaliz.= ON
Date/time= OFF
Quick start= OFF
Net total.= OFF
Currency= ON
Curr. decim.= 2
EUR/dm=+ 1.00000
EUR/dm=- 1.00000
Reset video= OFF
I+ reset
P+ reset
I- reset
P- reset

```

- 8.1 Choice of the language: EN= English, IT=italian, FR= French, SP= Spanish, DE=German
- 8.2 Updating frequency on the display: 1-2-5-10 Hz
- 8.3* Display contrast
- 8.4 Partial totalizer visualization (with batch enable the function is always on)
- 8.5 Date and time visualization with data logger enable
- 8.6 Quick start menu visualization
- 8.7 Enable the page of net totalizer (difference between direct and reverse)
- 8.8 Visualizes the values of the partial totalizers in the unit of selected currency
- 8.9 Choice of the numbers of decimals for the visualization currency value: From 0 to 3
- 8.10* Value of conversion/currency for direct totalizer
- 8.11* Value of conversion/currency for reverse totalizer
- 8.12 Reset the processor of the display (useful in case of particular badly operations of the display)
- 8.13* Total direct (positive) flow totalizer reset
- 8.14* Partial direct (positive) flow totalizer reset
- 8.15* Total reverse (negative) flow totalizer reset
- 8.16* Partial reverse (negative) flow totalizer reset

7-Communication

8-Display

```

9-Data logger
10-Diagnostic
11-Internal data
12-Batch

```

```

9-DATA LOGGER
1992/05/10 15:03
Acquisition= ON
Interval=h 24
Display data
Display events
Disp.min/max
Clear data
Clear events
Reset min/max

```

- 9.1* Date and time set
- 9.2 Automatic data logger enable
- 9.3 Interval time for the data logging function: 1, 2, 3, 6, 8, 12, 24, 48 hours
- 9.4 Displaying of the data stored in the data logger
- 9.5 Displaying of the last 64 alarms stored in the data logger
- 9.6 Visualization function of minimum and maximum peak of flow rate
- 9.7 Logged data cancel function
- 9.8 Reset all alarm events
- 9.9 Reset all minimum and maximum peak of flow rate stored

```

MAIN MENU
10-DIAGNOSTIC
Calibration
Self test
Simulation= OFF
Firmware rev.

```

- 10.1* Calibration of the converter
- 10.2* Autotest converter
- 10.3* Flow rate simulation enabling
- 10.4 Firmware revision/version

```

MAIN MENU
11-INTERNAL DATA
L2 keycode=00000
Load fact.pres.
Load user pres.
Save user pres.
Ign.cal.err= OFF
KS= +1.0000

```

- 11.1 Level 2 access code enter
- 11.2 Load factory data pre-set
- 11.3 Load user data saved
- 11.4 Save user data
- 11.5 Ignore the calibration error during the switch on test
- 11.6 KS coefficient (only for service purposes)

Menu 12: Menu visualized only with batch active (see from batch function configuration section)

```

12-BATCH
N.samples= 000
Diff.thr=% 010
V.com=dm³ 00.000
V.pre=dm³ 00.000
Auto batch= OFF
BM auto sel= OFF
Cons.mode= OFF

```

- 12.1* Number of batch cycles to define the value of compensation. Value 0=OFF
- 12.2* % limit of compensation threshold
- 12.3* Compensation value
- 12.4* Prebatch value
- 12.5* Auto-batch
- 12.6* Automatic selection of batch formula
- 12.7* Static consent of batch

FUNCTIONS DESCRIPTION

(description of the functions with access code < 3)

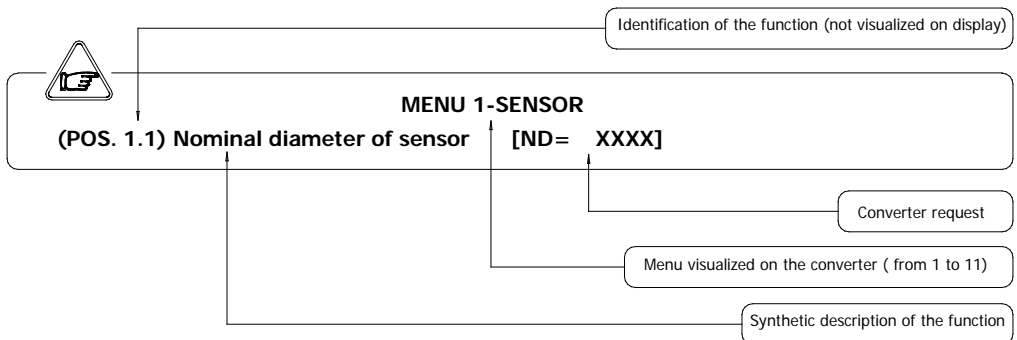

The following pages give a description of the most important functions and how they can be changed or enabled/disabled by the user

MENU 1 - SENSOR

(POS. 1.8) Electrodes cleaning

[El. Cleaning=MIN]

Selectable options: OFF, minimum, average and maximum. It is not recommended the use of this function (let OFF) when the liquid has a conductivity less than 100 μ S/cm.

(POS. 1.9) Empty pipe threshold

[E.P. thr.=XXX]

This value represents the threshold of measure block to zero in empty pipe condition; the span function is 20-250. Since the sensibility of empty pipe detection could be changed by the liquid conductivity, ground connections, type of lining, in case of needed it is possible to adjust manually the preset threshold. It is recommended to check periodically its proper functioning. Value increasing means sensibility decreasing.

(POS. 1.10) Autozero calibration

[Autozero cal.]

This function activates the zero calibration automatic system. To perform this operation, it is necessary for the sensor to be full of liquid, and the liquid be perfectly still. Even minimal movement of the liquid may affect the result, and consequently, the accuracy of the system. Once you are sure the above conditions have been fulfilled (and the percentage flow rate value is stable) press long the key  and automatically activates the zeroing procedure, after which it is necessary to check that the percentage value showed goes to zero, repeat the operation otherwise. When the value is stable at zero, then press the key **Enter**.

MENU 2 - SCALES

(POS. 2.1-2) Full scale n° 1-2

[Fs1-2=dm³/S X.XXXX]

The full scale is used to indicate to the maximum meter's flow rate; a volume per time is required. The full scale should be chosen carefully as its parameters are used for several other parameters (Pls1-2, and 3 Measure). There are four fields to fill in order to set this parameter, from left to right: 1) volume unit of measure, 2) type of unit, 3) time unit of measure and 4) numeric value. The selection is made by positioning the cursor on the field to modify. To change the type of unit of measure (metric, British or American, mass or volume) the cursor has to be positioned on the symbol "/" (field N. 2). When the nominal diameter is set to zero it is possible to modify only the numeric field, since the unit of measure stays at m/sec. The following tables show the units of measure available and the conversion factor by comparison with 1dm³ and 1kg. The converter accepts any kind of combination of units of measure satisfying both the following conditions:

- Numeric field value ≤ 99999
- $1/25 f_{s_{max}} \leq \text{numeric field value} \leq f_{s_{max}}$.

where $f_{s_{max}}$ is the maximum full scale value corresponding to the sensor, equal to a 10m/s liquid speed. The measure units are shown as appear on the display. The British and American units are diversified by using capital and small characters.

cm³	Cubic centimetre
ml	Millilitre
l	Liter
dm³	Cubic decimeter
dal	Decalitre
hl	Hectolitre
m³	Cubic metre

in³	Cubic inch
Gal	American gallon
GAL	British gallon
ft³	Cubic foot
Bbl	Standard barrel
BBL	Oil barrel
yd³	Cubic yard
kgl	KAmerican gallon
KGL	KBritish gallon

G	Gram
Kg	Kilogram
T	Ton

Oz	Ounce
Lb	Pound
Ton	short tons

When a measure mass unit is set, the specific gravity function is automatically enabled by the system. Please, note that the mass measure is heavily affected by the temperature. With certain liquids this may cause significant measurement errors. The following measure of time units can be selected: **s** = second, **m** = minute, **h** = hour, **d** = day.

(POS. 2.3) Measure unit and decimal totalizers number **[Tot.MU:dm³X.XXX]**

Setting the measure unit and decimals number for visualized totalizers or the volumes to batch. Setting the measure unit and decimals places number displayed for the volumes. To set the measure unit, position the cursor on field of the measure unit. To set the unit type, position the cursor on the blank space between the measure unit and the numeric value; the number decimal places can be selected by placing the cursor on numeric field and choosing one of the possible combinations: 1000-01.00-001.0-00001.

(POS. 2.4-5) Pulse value channel 1-2 and unit of measure of tot. **[Pls1-2=dm³X.XXXXX]**

This function allows the user to set a signal (a pulse) to be given from the converter when a defined amount of liquid has passed through the sensor. To set the parameter, complete the three fields, from left to right: 1) measure unit, 2) unit type and 3) numeric value. The selection is performed by positioning the cursor in the field to be modified. To change the unit type (metric, British or American, mass or volume) position the cursor on the blank space between the measure unit and the numeric value. When the nominal diameter is set to zero it is possible to modify only the numeric field since the measure unit stays at meters (m) or feet (ft). Only those units described above are available to be selected.

(POS. 2.6-7) Pulse duration channel 1-2 **[Tpls1-2=msXXXX.XX]**

With the liquid volume to generate the pulse value (pos 2.4-2.5) set by the user. The user must set the corresponding duration of the pulse to be outputted. This value is expressed in milliseconds and has to be between 0.4 and 9999.99. When the high frequency output is present, then the minimum value can type of device is connected to the converter, the user must verify that the set pulse duration is compatible with the external device processing such pulses. If, for example, an electro-mechanical pulse counter is connected, one of be set to a minimum of 0.04 milliseconds. ATTENTION: since the converter can not detect which two problems may occur; firstly, if the pulse is too long the coils may burn out, secondly, if the pulse is too short, the counter may not be able to function, with the possibility of causing damage of the output.

MENU 3 - MEASURE

(POS. 3.1) Main frequency filter **[AC filter=s XX.X]**

This function allow to filter electrical noise on the liquid coming from the main frequency. The allowed values are: 0.1s, 0.2s, 1.0s, OFF; 0.1s=ready measure, 0.2s=liquid noise filter, 0.5s=liquid STRONG noise filter.

(POS. 3.2) Measure filter**[M. filter=s XXX.X]**

This section of the manual is extremely important because the right settings of filters allow to get a proper meter reaction according to the flow rate behaviour.

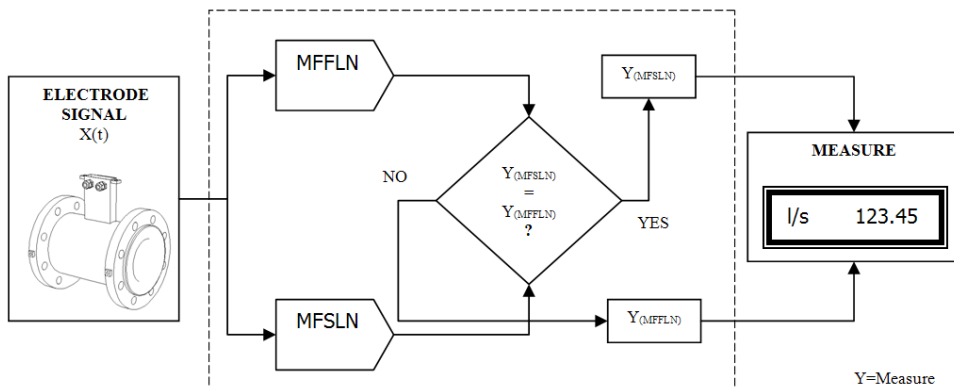
WORKING PRINCIPLE

There are two filters:

- MFSLN (Measure Filter Slow LeNght): available via ETP and through the display, in menu 3. Measure, function "M. filter"

The M. filter function effects the converter response time while measuring (it is like LOW PASS filter); the value needs to be chosen carefully as it effects the meter behaviours. A smaller value with a fluctuating flow will lead to unstable flow readings as the integration filter will be measuring over very short periods. A higher value corresponds to a more stable but slower measure, a smaller value gives a faster measure but is more unstable.

- MFFLN (Measure Filter Fast LeNght): is available **ONLY via ETP**

The MFFLN must be set by the user in accordance with the MFSLN (M. filter) to meet the required meter behaviour.

How the system functions: If the period of flow rate variation is over the MFFLN time (i.e. a slow flow variation), the outputs (display/4-20mA/Alarms) are refreshed according to MFSLN (M. filter); as soon as the flow rate variation is within MFFLN time, the output will be set immediately at the new value.

The combination of MFSLN & MFFLN is useful as it allows the converter to react quickly to large flow rate variations, regardless of the MFSLN (M. filter) set, therefore delaying (dampening) smaller fluctuations in flow, resulting in very stable measures.

The value of those parameters has to be within the range from 0 (filter disabled) to the maximum value defined on below table:

Sampling rate	M Filter (MFSLN)	F Filter (MFFLN)
10	100.0	15.00
20	50.0	7.50
50	20.0	3.00
80	12.5	1.88
150	6.7	1

The following diagrams show the response of the instrument for a flow rate variation from 0 to 100% of full scale set using different settings of filters.

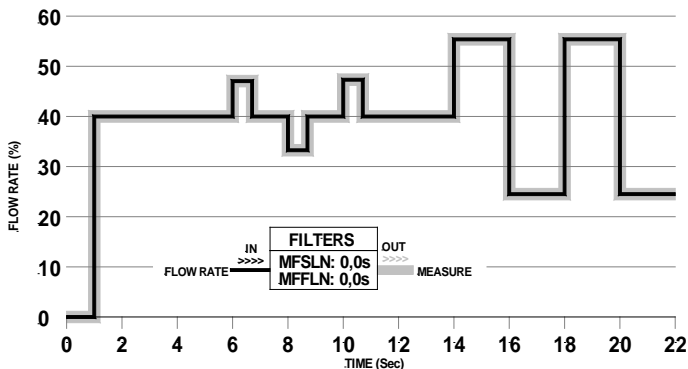

Both filters to zero (batching setup): the measure quickly follows the flow rate behaviour

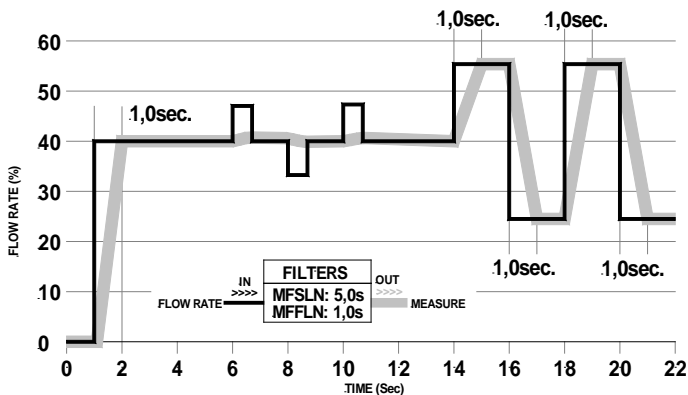

Both filters are used (Smart mode): prompt reaction to quick flow variation (based on the MFFLN value); smoothing the measure result to slow flow variations (based on MFSLN value)

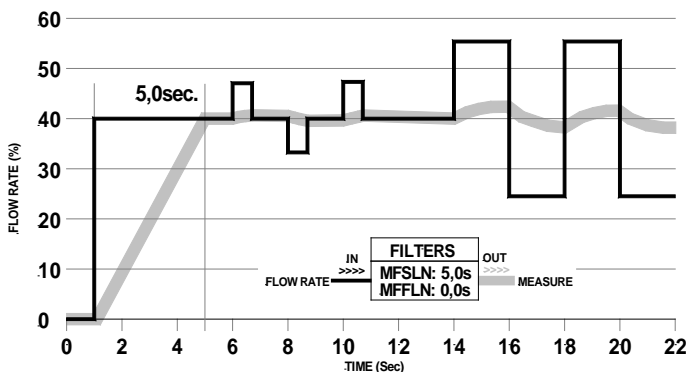

Only M. filter (MFSLN) is used (regulation and flow measure setup): smoothing the measure result (based on MFSLN value) in reaction to quick and slow flow variation (MFFLN does not work).

(POS. 3.5) Automatic scale change enable**[Autorange=ON/OFF]**

Enables the automatic change of scale. The meter may have two different working ranges in order to suit to the variable process conditions. In order to get the best results out of this function it is important range N.2 (Fs2) if enabled is bigger than N.1 (Fs1). When the flow rate increases and reaches the 100% of the full scale 1, then the meter automatically switches to scale 2. When the flow rate decreases again reaching a value on scale 2 equal to the 90% of full scale N.1, then the active scale is 1 again. Allowed values for this parameter: ON/OFF. **Note:** the autorange does not allow using the range change external command (pos. 5.8).

(POS. 3.6) Energy saving enable**[E.saving=ON/OFF]**

Automatic energy saving function enables. This function is used when the instrument is powered by a battery or solar cells, allowing an energy saving up the 60-80%. The energy saving function controls the powering cycles ratio of the coils while the measuring cycling remain unaffected. When the energy saving function is enabled and the flow rate is stable the number of "off" cycles is greater than the "on" cycles, reducing the average power consumption. If the flow rate suddenly changes, the meter switches to a higher number of measuring cycles, achieving a higher response time. To allow this function to work properly set the SMART measure setup (see quick start menu).

MENU 4 - ALARMS**(POS. 4.6) Current output value in case of failure****[mA V.fault =% XXX]**

The output current signal can be specified by the user in case of failure of either, empty pipe, coils interrupted, or ADC error. The signal current is set as a percentage (0 to 120%) of the 0/4-20mA current. 120% corresponds to 24mA and does not depend on the selected range (0-20/4-20mA).

The NAMUR NE43 recommendation asks for a alarms signalling value for the current output lower than 3.6mA (<18%) or bigger than 21mA (>105%). It would then be preferable to set the value of this function at the 10%, so that the current value in case of the a.m. cases would be 2 mA, allowing the following diagnostics:

- current < 2mA - 5%: line interrupted, power supply failure or faulty converter;
- 2mA -5% ≤ current ≤ 2mA + 5%: hardware alarm;
- 4mA ≤ current ≤ 20mA: normal working range;
- 20mA < current ≤ 22mA: out of range, measure above 100% f.s.

Note: To set this parameter to zero disables the alarm

(POS. 4.7) Frequency output value in case of failure**[Hz V.fault=%XXX]**

To set the frequency value assigned to the on/off output in one or more of the following failure cases:

- Empty pipe; Coils interrupted ; ADC error

Allowable range is from 0 to 125% of the frequency full scale value.

Although there are no specific rules regulating cases such as these, it would be convenient to use the failure information as follows:

- 0% Hz ≤ frequency ≤ 100% f.s.: normal working range;
- 100% f.s. < frequency ≤ 110% f.s.: overflow, measure above the 100% of the f.s.;
- 115% f.s. ≤ frequency ≤ 125% f.s.: hardware alarm condition.

(POS. 4.8) Batch safety timer**[Timeout =s XX.X]**

With this function is possible to set a maximum time for the batch ; over this time will be generate an alarm.

This function is useful when you need control one or both of the following conditions:

- batch valve open and flow rate is zero
- batch valve closed and flow rate different to zero

When this alarm is activate, the batch operation and power supply to the value is halted. The allowed values of function are from 0 (disable) to 25.5 seconds and is active only if one or more of the batch functions are enabled.

MENU 5 - INPUTS

(POS. 5.1-4) Reset totalizer enable**[T/P+/-RESET=ON/OFF]**

When one of this function is enabled, the related totalizer may be reset through the on/off input.

(POS. 5.7) "Autozero" calibration external command enable**[Calibration=ON/OFF]**

When this function is active, applying a voltage on the on/off input terminals the meter performs a autozero calibration cycle. ATTENTION: If the voltage pulse is less than 1 sec., the meter performs a calibration cycle to for compensate possible thermal drifts. If the voltage pulse is more 1 sec, the meter performs a zero calibration measure. This function enables/disables the automatic zero calibration of the system. To perform the calibration it is absolutely necessary for the sensor to be full of liquid and that the liquid is perfectly staying still. Even very small movement of the liquid may affect the result of the calibration, and, consequently, the accuracy of the system.

(POS. 5.10) Functions assigned to input 2**[Inp.2=XXXXXX]**

Allows to choose the function associated to input 2. The functions are listed in the table below.

FUNCTIONS FOR INPUT 2

OFF: DISABLE

T+ RESET: RESET TOTAL DIRECT TOTALIZER FOR DIRECT FLOW RATE (+)**P+ RESET:** RESET PARTIAL DIRECT TOTALIZER FOR DIRECT FLOW RATE (+)**T- RESET:** RESET TOTAL REVERSE TOTALIZER FOR REVERSE FLOW RATE (-)**P- RESET:** RESET PARTIAL REVERSE TOTALIZER FOR REVERSE FLOW RATE (-)**BATCH:** START/STOP BATCH**BM SELECT:** STATIC SELECTION OF FORMULA

MENU 6 - OUTPUTS

(POS. 6.1-4) Function corresponding to on/off output 1-2-3-4**[OUT1=XXXXXX]**

Choice of the function corresponding to digital outputs. The functions are listed in the table below.

The output 3-4 are optional and the output 4 is the only output, which can reach a 12.5 kHz frequency.

FUNCTIONS ASSOCIATED TO THE OUTPUTS 1, 2, 3, 4

OFF: DISABLED

#1 IMP+: PULSE ON CHANNEL 1 FOR POSITIVE FLOW RATE

#1 IMP-: PULSE ON CHANNEL 1 FOR NEGATIVE FLOW RATE

#1 IMP: PULSE ON CHANNEL 1 FOR POSITIVE AND NEGATIVE FLOW RATE

#2 IMP+: PULSE ON CHANNEL 2 FOR POSITIVE FLOW RATE

#2 IMP-: PULSE ON CHANNEL 2 FOR NEGATIVE FLOW RATE

#2 IMP: PULSE ON CHANNEL 2 FOR POSITIVE AND NEGATIVE FLOW RATE

#1 FREQ+: FREQUENCY CHANNEL 1 FOR POSITIVE FLOW RATE

#1 FREQ-: FREQUENCY CHANNEL 1 FOR NEGATIVE FLOW RATE

#1 FREQ: FREQUENCY CHANNEL 1 FOR POSITIVE AND NEGATIVE FLOW RATE

#2 FREQ+: FREQUENCY CHANNEL 2 FOR POSITIVE FLOW RATE

#2 FREQ-: FREQUENCY CHANNEL 2 FOR NEGATIVE FLOW RATE

#2 FREQ: FREQUENCY CHANNEL 2 FOR POSITIVE AND NEGATIVE FLOW RATE

SIGN: FLOW DIRECTION OUTPUT (ENERGIZED = -)

RANGE: RANGE INDICATION OUTPUT (ENERGIZED = SCALE 2)

MAX AL+: MAX DIRECT FLOW RATE OUTPUT(ENERGIZED = AL. OFF)

MAX AL-: MAX REVERSE FLOW RATE OUTPUT(ENERGIZED = AL. OFF)

MAX AL.: MAX DIRECT/REVERSE FLOW RATE OUTPUT(ENERGIZED = AL. OFF)

MIN AL+: MIN DIRECT FLOW RATE OUTPUT(ENERGIZED = AL. OFF)

MIN AL-: MIN REVERSE FLOW RATE OUTPUT(ENERGIZED = AL. OFF)

MIN AL.: MIN DIRECT/REVERSE FLOW RATE OUTPUT(ENERGIZED = AL. OFF)

MAX+MIN: MAX AND MIN FLOW RATE ALARM OUTPUT (ENERGIZED = AL. OFF)

P. EMPTY: EMPTY PIPE ALARM OUTPUT (ENERGIZED = FULL PIPE)

OVERFLOW: OUT OF RANGE ALARM OUTPUT (ENERGIZED = FLOW RATE OK)

HARDW AL.: CUMULATIVE ALARM OUTPUT interrupt coils, empty pipe, measure error (ENERGIZED = NO ALARMS)

BATCH AL.: BATCH ALARM

EXT. COMM.: ONLY AVAILABLE WITH DATA LOGGER MODULE

BATCH SYN.: AT THE AND OF BATCH THE OUTPUT CHANGE STATUS

END BATCH.: END BATCH OUTPUT (ENERGIZED =BATCH IN PROGRESS)

PREBATCH.: PREBATCH OUTPUT (ENERGIZED = PREBATCH IN PROGRESS)

(POS. 6.5-6) Function and the range of current output n.1-2 [Out mA1-2=X÷XX+]

The function associated to the signal current on output N.1-2. The current output N.1 is **optional and it is mounted on the main board**. There are three fields to modify for this function:

- Scale zero: **4** or **0mA**;
- Full scale: **20** or **22mA**
- Field: + = positive, - = negative, blank = both, -0+ = central zero scale

The values corresponding to the scale points are shown in the following chart:

POSSIBLE FIELD	CURRENT VALUES IN mA ASSOCIATE TO THE % VALUE OF FULL SCALE				
	REVERSE FLOW VALUE		ZERO	DIRECT FLOW VALUE	
	≤ -110%	-100%	0%	+100%	≥+110%
OutmA = 0 ÷ 20 +	0	0	0	20	20
OutmA = 0 ÷ 22 +	0	0	0	20	22
OutmA = 4 ÷ 20 +	4	4	4	20	20
* OutmA = 4 ÷ 22 +	4	4	4	20	22
OutmA = 0 ÷ 20 -	20	20	0	0	0
OutmA = 0 ÷ 22 -	22	20	0	0	0
OutmA = 4 ÷ 20 -	20	20	4	4	4
OutmA = 4 ÷ 22 -	22	20	4	4	4
OutmA = 0 ÷ 20	20	20	0	20	20
OutmA = 0 ÷ 22	22	20	0	20	22
OutmA = 4 ÷ 20	20	20	4	20	20
OutmA = 4 ÷ 22	22	20	4	20	22
OutmA = 0 ÷ 20 -0+	0	0	10	20	20
OutmA = 0 ÷ 22 -0+	0	1	11	21	22
** OutmA = 4 ÷ 20 -0+	4	4	12	20	20
OutmA = 4 ÷ 22 -0+	4	4.8	12.8	20.8	22

In hardware alarm conditions "HARDW AL." (interrupted coils, empty pipe, measure error) the current value is programmed by the function "mA v.fault" (pos. 4.6) and it is expressed as percentage of a fixed current range, where: 0% = 0mA and 110% = 22mA.

* Example 1: out 4-22 +

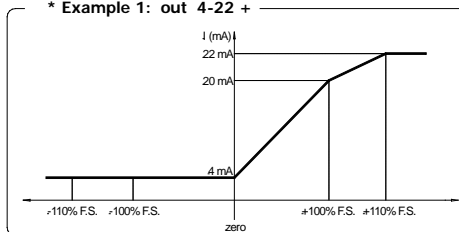

** Example 2: out 4-20 -0+

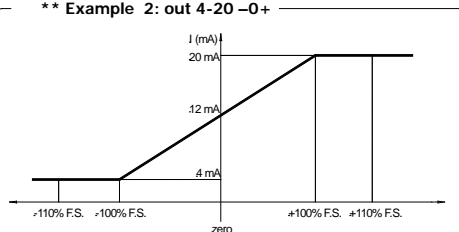
**MENU 8 - DISPLAY****(POS. 8.3) Display contrast set****[Contrast=X]**

Visual display contrast set. The contrast can change according to the room temperature. The set values are from 0 to 15. The entered value has effect only when leaving the function itself.

WARNING >10 is a dark screen and obscures writing on the display

Contrast also can be set from visualization pages pushing the key  for 8 seconds or more. In this way the contrast set that will be visualized at release of the key.

(POS. 8.10-11) Conversion factor for flow rate totalizers**[EUR/dm³ +/- =X]**

Setting of the conversion/currency value for direct (and reverse) flow totalizers. There are three setting fields for this parameter, from left to right: 1) monetary symbol, 2) default/personalized monetary symbol, 3) conversion coefficient. To modify, set the cursor over the required field. Setting the monetary symbol can be achieved in two ways:

- Choosing one of the 7 predetermined monetary symbols (standard ISO 4217-REV81): EUR=Euro; USD=USA dollar; CAD=Canadian dollar; AUD=Australian dollar; GBP=English pound; CHF=Swissfranc; JPY=Japanese yen.
- Entering a three character (numbers or letters) personalized currency. To change the characters, the cursor must be set on the symbol "/" (second field)

(POS. 8.13-16) Total/partial totalizers reset**[T/P/-/+ reset]**

Activates the reset of total and partial flow totalizer. These functions are activated by pressing the key **Enter** during the visualization of the function itself. When "EXECUTE?" is required, press long **Enter** to proceed. Press any other key to delete the operation.

MENU 9 - DATA LOGGER**(POS. 9.1) Date and time set****[☉ = dd/mm/yy hh:mm]**

Date and time set. If the real time clock optional module is present, then the time setting is kept when the converter power supply is off, otherwise the clock is frozen until the power supply to the converter is resumed. For example, if the power supply has been off for one hour, when switched on the converter will be one hour behind actual time. The calendar is valid till year 2091.

MENU 10 - DIAGNOSTIC**(POS. 10.1) Meter calibration****[Calibration]**

Enables the calibration of the meter. The activation of this function happens pressing the key **Enter** during the visualization of the function. The following message will be visualised on the screen: "EXECUTE?" press long the key **Enter** to proceed. Press any other key to delete the operation.

(POS. 10.2) Autotest function**[Self test]**

Meter autotest function. This function stops the normal functions of the meter and performs a complete test cycle on the measure input circuits and on the excitation generator. To activate this function, after select it, push key **Enter**, at the question: "EXECUTE?" push long the same key for start autotest, or any other key for delete operation. The result of the test is shown on the display. At the end of operation the converter will revert to one of the initial visualization pages. This function is automatically performed when switching on the device.

(POS. 10.3) Flow rate simulation**[Simulation=ON/OFF]**

Flow rate simulation enabling. With this function it is possible to generate an internal signal that simulates the flow rate, allowing the outputs and all the connected instruments test. After enabling it, a 'S' appears in the top left of the screen and the flow rate simulation can be:

- set: by pushing the key **Enter** from one of visualization pages, to set the required % flow rate (Fl.rate=%) and the same key to confirm the value;
- finished: by pushing the key **Enter** from visualization pages and then by long pushing the same key.

The batch functions allow the user to set the converter to measure a defined volume of fluid and control outputs. An example is opening and closing a valve after a predefined volume has passed the sensor. The user sets the volume and the control parameters by the converter through the following functions (Main menu function group 12 'Batch')

MENU 12 - BATCH

Menu visualized only with batch active (output on batch and/or pos. 5.9 enable or 5.10 on batch)

(POS. 12.1) Number of batch samples [N.samples=XXX]

Number of batch cycles to be completed to define the value of compensation. This function allows the converter to automatically determine the average value for the automatic compensation of the system delay (pos. 12.3). Set the value to ZERO to manually introduce the compensation value.

(POS. 12.2) % limit of compensation [Diff.thr=%XXX]

This value defines the percentage of maximum difference between the compensation value set (see pos. 12.3) and the average compensation value defined with the function 12.1. Over this threshold the new compensation value will be automatically set (if number of batch samples is different from zero)

(POS. 12.3) Compensation value [V.com.=XX.XXX]

This value is expressed in the units of measure selected. The compensation value is the difference between the batch value set and the actual system delays due to closing valves, stop pumps, stop motors, etc. To set the compensation value manually, preset to ZERO the number of batch samples (pos. 12.1)

(POS. 12.4) Prebatch value [V.pre=XX.XXX]

This sets the volume of liquid at which the Pre-batch is enabled. When the pre-batch volume (V.pre) is reached the output (if enabled) is deactivated. This value is constant for all quantities to be batched and must be set in current volume unit of measure. The pre-batch function is useful when you need fast and accurate dosages.

(POS. 12.5) Enable/disable auto-batch function [Auto batch=ON/OFF]

By applying a voltage to the on/off input terminals for more than 5 second opens the valve controlled by the converter. When the required flow volume has passed, the input voltage is removed, closing the valve. The converter memorizes the volume supplied in the current batch memory. (see "Batch Functions"). The volume set in this procedure will be the batch volume supplied in every following activation of the batch function. In order to modify this value, repeat the operations described above. This procedure set the safety timer at a value 1.25 times greater than the time used to reach the batched quantity; after that the counter will be reset.

(POS. 12.6) Automatic selection of batch formula [BM auto sel=ON/OFF]

The function allows the automatic selection of the first 4 formulas depending on the duration of the pulse of the batch start (see page 15 "Operation stage on input 1 or 2"). This function is active only if the function Cons. mode (pos. 12.7) has not enabled (OFF). With the 'Static consent of batch', the automatic compensation of the batch volume is excluded (additionally the value of the parameter "N.samples" (pos. 12.1) will be automatically be set to zero). However the manual compensation is possible by inserting an appropriate value on the parameter "V.com" (pos. 12.3)

(POS. 12.7) Static consent of batch [Cons. mode=ON/OFF]

This function enables the start and stop of the batch dosing using a static signal, instead of an impulse, applied to the input (see page 13 "Digital inputs"), this signal has to be constantly applied throughout the batch. This function automatically disables the functions 'BM auto sel' (pos. 12.6) and 'Auto batch' (pos. 12.5).

BATCH FUNCTION CONFIGURATION

ENABLE BATCH

Select one of the following functions to enable and program the batch on the converter:

- POS. 5.9-10: START/STOP batch from input
- POS. 6.1-2: assign one of the functions outputs one and/or two

Some examples of operation of such functions are visualized from page 14.

VISUALIZATION PAGE WITH BATCH FUNCTION ENABLED

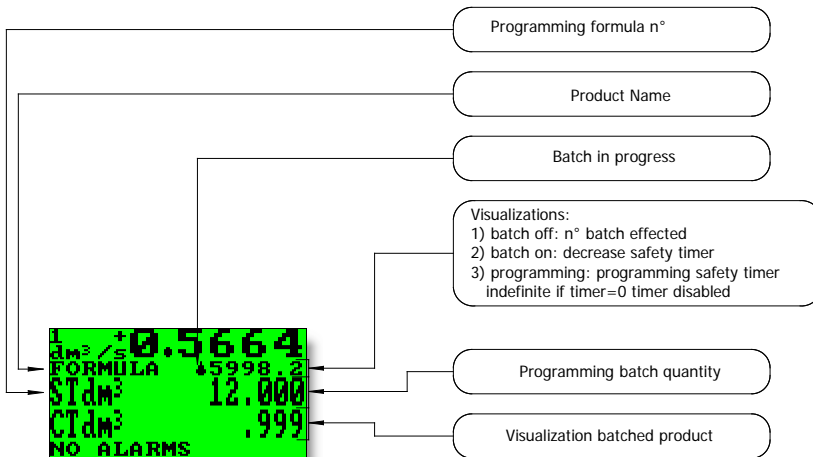

From the visualization pages

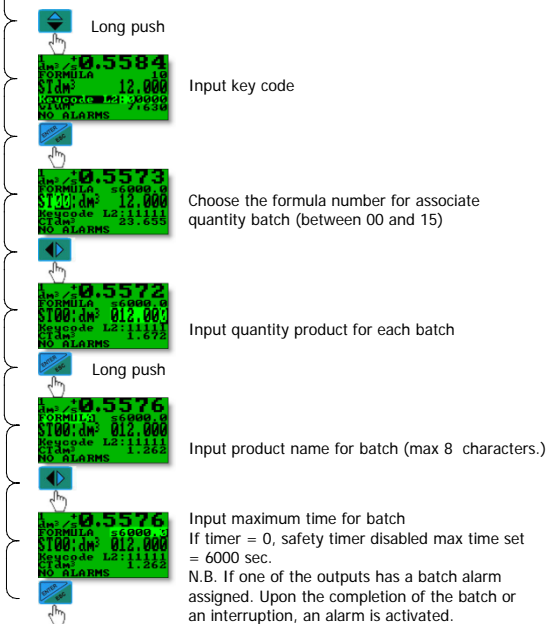

PROGRAMMING A BATCH

For each formula you can associate:

- Product quantity
- Product name
- Maximum time for batch (safety time for each formula)

After activating the batch function from visualization page, proceed as illustrated and described in the aside example.

START STOP BATCH



START: it is possible to activate the start of batch in two different ways:

1. **From remote input:** assigning the functions of start/stop batch to the input 1 (pos. 5.9) or input 2 (pos. 5.10) and using the inputs like visualized from page 14.
2. **From keyboard:** short pressing of the key .
N.B.: The start of batch from keyboard is always initiated on the release of the key. The function is not available with the batch consent (pos. 12.7) function enabled.

STOP: A batch may stop (be stopped) due to three events:

1. **Keyboard or remote input** (manual stop): short pressing of the key .
2. **End of batch:** In this case the batch will be stopped once the batch quantity has been achieved and a signal given
3. **Maximum time of batch:** If a maximum batch time has been set, and is exceeded, the batch in progress is stopped independently from the batched quantity.

Notes:

- during the batch the symbol of the active batch  and the name of the formula are visualized on display.
- When the batch outputs are enabled, pushing the  key for more than 5 seconds will energize the outputs until the key is released. On the display, In place of the CT and ST totalizers the following message will appear:

!! VALVE !!
!! OPENED !!

IMPORTANT NOTES

The start of the batch disables any function listed in the table below:

	POS 12.5	POS 12.6	POS 5.6	POS 12.1	POS 5.9	POS 3.5-5.8	POS 3.6	POS 5.7
* If using Input 1 ** Value set to zero	AUTO BATCH	BM AUTO SEL	BLOCK TOTALIZER	N. SAMPLES	INPUT 1 ON START/STOP BATCH	AUTO RANGE CHANGE OR FROM I INPUT	ENERGY SAVING	CALIBRATION
POS 12.5	AUTO BATCH		*DISABLE					
POS 12.6	BM AUTO SEL			** DISABLE				
POS 12.7	CONS. MODE	DISABLE	DISABLE	* DISABLE				
POS 5.9	INPUT 1 ON START/STOP BATCH					DISABLE	DISABLE	DISABLE
POS 5.10	INPUT 2 ON START/STOP BATCH				DISABLE	DISABLE	DISABLE	DISABLE
POS 5.10	INPUT 2 ON BM SELECT	DISABLE		** DISABLE				
POS 6.1-4	OUTPUT ON END BATCH						DISABLE	

To optimize the performances of the meter used as a batch instrument (batch time < 5s), it is recommended to set it as prompt as possible according to the plant requirements, choosing the **batching setup** for the automatic parameter optimization of the quick start menu. It is also recommended to deactivate the function 3.1, AC filter.

ALARM MESSAGES

CAUSES AND ACTIONS TO BE TAKEN

Messages	ANOMALIES	ACTION TO TAKE
NO ALARMS	All works regularly	-----
MAX ALARM	The flow rate is higher than the maximum threshold set	Check the maximum flow rate threshold set and the process conditions
MIN ALARM	The flow rate is lower than the minimum threshold set	Check the minimum flow rate threshold set and the process conditions
FLOW RATE > FS	The flow rate is higher than the full scale value set on the instrument	Check the full scale value set on the instrument and the process conditions
PULSE/FREQ>FS	The pulse generation output of the device is saturated and cannot generate the sufficient number of impulses	Set a bigger unit of volume or, if the connected counting device allows it, reduce the pulse duration value
EMPTY PIPE	The measuring pipe is empty or the detection system has not been properly calibrated	Check whether the pipe is empty or repeat the empty pipe calibration procedure
BATCH ALARM	Batch interrupted for the followings condition: <input type="checkbox"/> Timer batch expired before the end of the batch <input type="checkbox"/> Batch valve open and flow rate to zero for a time longer to the safety timer set <input type="checkbox"/> Batch valve closed and flow rate different from zero for a time longer than the safety timer set	Verify: <input type="checkbox"/> Presetting <input type="checkbox"/> System conditions
INPUT NOISY	The measure is strongly effected by external noise or the cable connecting the converter to the sensor is broken	Check the status of the cables connecting the sensor, the grounding connections of the devices and the possible presence of noise sources
EXCITATION FAIL	The coils or the cable connecting the sensor are interrupted	Check the connecting cables to the sensor
CURR. LOOP OPEN	The 4-20mA output on board or the optional one are not correctly closed on a valid load	Verify the load is applied to the output (max 1000 ohm). To disable the alarm, set the "mA V.fault" value (menu alarm) to 0.
P.SUPPLY FAIL	Power supply different from that indicated on the label.	Verify that the power supply is with in the specifications indicated on the label

ANOMALIES CODES

CODES	ANOMALIE DESCRIPTIONS	ACTION TO TAKE
0001	Problem with watch-dog circuit	ADDRESSING TO SERVICE
0002	Wrong configuration work data in eeprom	
0004	Wrong configuration safety data in eeprom	
0008	Defective eeprom	
0010	Defective keyboard (one or more key are pushed during the test)	
0020	Power supply voltage (+3.3) is out of range	
0040	Power supply voltage (+13) is too low (<10V)	
0080	Power supply voltage (+13) it's too high (>14V)	
0200	Timeout calibration input (input circuit is broken)	
0400	Gain input stage is out of range	
0800	Interruption on the coils circuit	Check the status of the cables connecting the sensor to the converter
0C00	Cumulative alarm 0800 + 0400	See single codes 0800 and 0400 above.

APPENDIX

DISPLAY ROTATION PROCEDURE

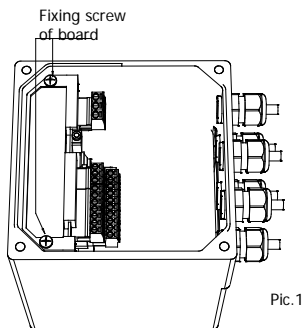

Pic. 1

- ❑ Unscrew the screw as indicated in pic. 1

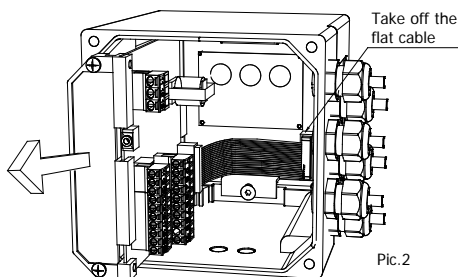

Pic. 2

- ❑ Lift the board, remove the flat cable from the display (pic. 2) and extract completely the board from the box

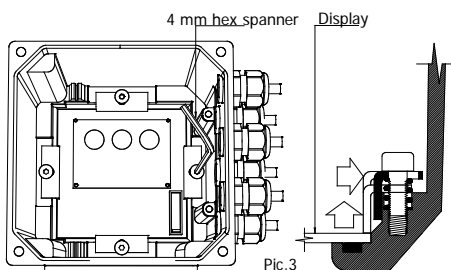

Pic. 3

- ❑ Partially unscrew the screw fixing the display to allow the angular shift and extraction of the display

N.B.: Do not unscrew entirely the screw

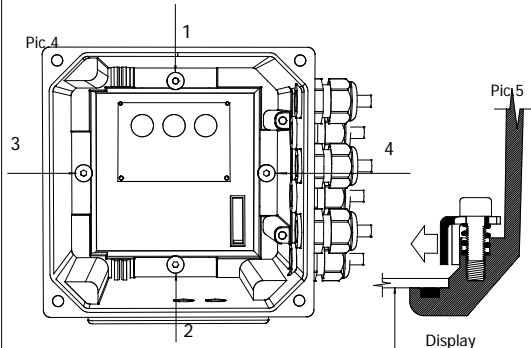

Pic. 4

Pic. 5

Display

- ❑ Rotate the display to the desired location, verify the correct set of the seal, the cleaning of the contact surfaces it set the display housing.
- ❑ Place the fixing angles in the suitable positions (pic. 5) and screw down firmly until they make contact with the display housing.
- ❑ Screw up tightly the 4 screws (1, 2, 3, 4) indicated in pic. 4

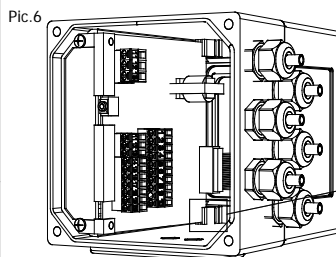

Pic. 6

Pic. 7

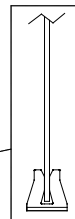

- ❑ Restore the flat cable connection to the display
- ❑ Verify the board is set correctly in the fixing clip (pic. 7)
- ❑ Fix the board to the box to complete the assembly process.

Note: the display is rotatable ONLY in the aluminum IP67 version.

SERVICE: return form for instrument repair or calibration

ISOMAG RETURN MATERIAL FORM AND CLEANING UP CERTIFICATE RMA

n° _____

Shipping Address:

ISOIL INDUSTRIA S.p.A.

Via Piemonte, 1

35044 MONTAGNANA (Padova)

Italy

Dear Friend,

to improve the SERVICE QUALITY and the SAFETY, please read, complete and attach this document (RMA) to the material you intend to send. Failure in RMA compilation will not allow us to be able to take charge of the materials.

Sender: _____ **Ref. D.D.T. n.** _____ **of** ____/____/____

- A detailed set of instructions for testing the sensor isolation and continuity is given in the service manual. If you are experiencing problems that are not related to the physical integrity of the sensor (water ingress, body, liner, connector or electrodes damage for example) we kindly ask you to test the sensors isolation and continuity. If the sensor passes these tests then we ask you to consider not returning this sensor without first consulting isomagservice@isoil.it
- In the case that the converter or sensor is returned and it is not repairable inside the warranty agreement terms or the inspection report is not accepted a cost for any converter testing and sensor dry testing and inspection will be mandatorily debited.
- Please send the sensor clean from medium. Additionally please inform about eventual medium wastes remaining in the sensor. For this purpose please use this form.
- A safety specification sheet of the medium must accompany this repair note in the following cases: toxic, otherwise dangerous or objectionable medium, or medium belonging to any dangerous material class.
- Please note that the instruments sender will be charged for any necessary cleaning costs. Additionally, we reserve the right to send the instruments back to the sender for cleaning!
- Please kindly state the observed failure and, eventual causes.

Sensor: MS _____ Serial number: _____

Failure description: _____

Converter: ML _____ Serial number: _____

Failure description: _____

We herewith confirm that above mentioned sensor has been cleaned and it is therefore free of any liquid and/or solid wastes of the measuring medium and/or cleaning medium. Any eventually remaining wastes are:

Measuring medium: _____

harmful/
injurious

no

yes; in this case, safety specification sheet must be attached!

Sensor cleaned with: _____

Further notes: _____

Date

Company stamp

e-mail address (for questions)

Signature of person in charge

CONFORMITY DECLARATION

Isoil Industria spa

Declares that the product line:

ISOMAG ™

Converter model:

ML 210

And sensor models

**MS 501 – MS 600 – MS 1000 – MS 2410 – MS 2500 – MS 3770 –
MS 3800 – MS 5000**

to which this declaration refers, are in compliance with the following
Harmonized European Norms:

- **EN 61010-1:2010**
- **EN 61326-1:2006**

and therefore comply to the following CE requirement directives:

- **2006/95/CE (Low voltage directive – LVD)**
- **2004/108/CE (Electromagnetic compatibility Directive – EMC)**

04/03/2011

THE LEGAL REPRESENTATIVE

ISOIL 
INDUSTRIA

via F.lli Gracchi, 27 20092 Cinisello Balsamo (MI)
Tel. +39-02-660271
Fax +39-02-6123202

ADDRESSES

Isoil Industria spa

Head office

20092 Cinisello Balsamo (MI) Italy

27, via F.lli Gracchi

Phone +39-02-66027.1

Fax +39-02-6123202

E-mail: sales@isoil.it

Web: www.isoil.com

Service

Isoil Industria spa

20092 Cinisello Balsamo (MI) Italy

27, via F.lli Gracchi

Phone +39-02-66027.1

Fax +39-02-6123202

E-mail: isomagservice@isoil.it



North America Distribution:



FLOMOTION SYSTEMS Inc.

3 N. Main St, Middleport, NY 14105

Toll Free: (800)909-3569 (U.S. & Canada)

Tel: (716)691-3941 ~ Fax: (716)691-1253

info@flomotionsystems.com

www.FlomotionSystems.com