

ISOMAG ™

The friendly magmeter

OPERATING AND INSTALLATION MANUAL

ELECTROMAGNETIC FLOW METER

ML 800



ISOIL 
INDUSTRIA
The solutions that count

Release number: ML800_EN_IS_R0_3.00.0XXX.docx – The characters of file name in bold type indicate the software version which the manual refers to; it is visualized at the instrument start up, or by specific function on DIAGNOSTIC menu.

INDEX

Introduction	4
Safety informations	4
Safety conventions	5
Technical characteristics	6
Electric characteristics	6
Environmental use conditions	6
Operating temperature	6
Data plate	6
Overall dimensions	7
Electrical connections	8
Grounding	8
Connector	8
Power supply	9
Inputs/outputs	10
Operation on input on/off	10
Wirings	11
Flags and led interpretation	12
Flow rate visualization	13
Access codes	13
Access to the configuration menu	14
Visualization pages	15
Quick start menu	16
Examples	17
Programming functions	19
Functions description	21
Alarm messages	26
Service: return form for instrument repair or calibration	28
Conformity declaration	30
Addresses	32

INTRODUCTION

These operating instructions and description of device functions are provided as part of the scope of supply. They could be modified without prior notice. The improper use, possible tampering of the instrument or parts of it and substitutions of any components not original, renders the warranty automatically void.

The reproduction of this manual and any supplied software is strictly forbidden.

SAFETY INFORMATIONS

Any use other than described in this manual affects the protection provided by the manufacturer and compromises the safety of people and the entire measuring system and is, therefore, not permitted.

The manufacturer is not liable for damaged caused by improper or non-designated use.

- 1) Transport the measuring device to the measuring point in the original packaging. In case of cartons packaging it is possible to place one above the other but no more than three cartons. In case of wooden packaging do not place one above the other.
- 2) Disposal of this product or parts of it must be carried out according to the local public or private waste collection service regulations.
- 3) The electromagnetic flow meter must only be installed, connected and maintained by qualified and authorized specialists (e.g. electrical technicians) in full compliance with the instructions in these Operating Instructions, the applicable norms, legal regulations and certificates (depending on the application).
- 4) The specialists must have read and understood these Operating Instructions and must follow the instructions it contains. If you are unclear on anything in these Operating Instructions, you must call the ISOIL service. The Operating Instructions provide detailed information about the instrument.
- 5) The flow meter should only be installed after having verified technical data provided in this operating instructions and on the data plate.
- 6) Specialists must take care during installation and use personal protective equipment as provided by any related security plan about risk assessment.
- 7) Never mount or wire ML 800 while it is connected to the power supply and avoid any liquid contact with the instrument's internal components.
- 8) Before connecting the power supply check the safety equipment.
- 9) Repairs may only be performed if a genuine spare parts kit is available and this repair work is expressly permitted.
- 10) For the cleaning of the device use only a damp cloth, and for the maintenance/repairs contact the service center (for details see the last page).
- 11) To return the product back for service complete and return the meter with form found on the last pages of this operating instructions.

Before starting up the equipment please verify the following:

- Power supply voltage must correspond to that specified on the data plate
- Electric connections must be completed as described
- Ground (earth) connections must be completed as specified

Verify periodically (every 3-4 months):

- The power supply cables integrity, wiring and other connected electrical parts
- The suitable tightness of the sealing elements (cap, connector and screws)
- The mechanical fixing of the converter to the pipe or wall stand.

SAFETY CONVENTIONS



DANGER

Warning indicates an action or procedure which, if not performed correctly, can result in injury or a safety hazard. Comply strictly with the instructions and proceed with care.



WARNING

Caution indicates an action or procedure which, if not performed correctly, can result in incorrect operation or destruction of the device. Comply strictly with the instructions.



NOTES

Note indicates an action or procedure which, if not performed correctly, can have an indirect effect on operation or trigger an unexpected response on the part of the device.

TECHNICAL CHARACTERISTICS



ELECTRIC CHARACTERISTICS

Instrument classification: class I, IP67, installation category II, rated pollution degree 2.

Power supply version	Power supply voltage	Pmax
LLV	18-30V $\overline{=}$	1W

- Voltage variations must not exceed $\pm 10\%$ of the nominal one.
- Digital input/outputs are insulated up to 500V.
- 4-20mA output not insulated from power supply.



ENVIRONMENTAL USE CONDITIONS

- The instrument can be installed inside or outside buildings
- Altitude: from -200m to 2000m (from -656 to 5602 feet)
- Humidity range: 0-100% (IP 67)

OPERATING TEMPERATURE

ENVIRONMENTAL TEMPERATURE			LIQUID TEMPERATURE		
	Min. *	Max		Min. *	Max
°C	-10	60	°C	-10	100
°F	14	140	°F	14	212

* For discontinuous use, a thermostat heat source installation may be necessary.

Data plate

On the data plate there is some technical information:

- **Conv.Mod.:** Converter model
- **Conv.s/n:** Converter serial number
- **Power S./MP:** Power Supply/Maximum Power consumption
- **Sensor Mod:** Sensor model
- **Sens s/n:** Sensor serial number
- **DN:** Nominal diameter
- **PN:** Nominal pressure
- **IP:** Protection grade
- **Fittings :** Process connections
- **Lining:** Sensor lining
- **Max Temp.:** Maximum liquid temperature
- **Electrodes:** Number electrodes and materials
- **KA:** KA
- **ITEM:** Free for user

ISOIL INDUSTRIA		CE
<small>Chiusello B. (MI) - ITALY www.isoil.com</small>		
Conv. Mod.	Conv Model	
Conv.s/n	ConvMatricola	
Power S./MP	18 - 30 VDC / 1W	
Sensor Mod.	SensModel	
Sens s/n	SensMatricola	
DN	SensDn	
PN	SensPn	
IP	67	
Fittings	SensFitt	
Lining	SensLining	
Max Temp.	SensTemp	
Electrodes	SensElectrodes	
KA	SensKA	
Item	ITEM	
MADE IN ITALY		
← FLOW DIRECTION →		

OVERALL DIMENSIONS

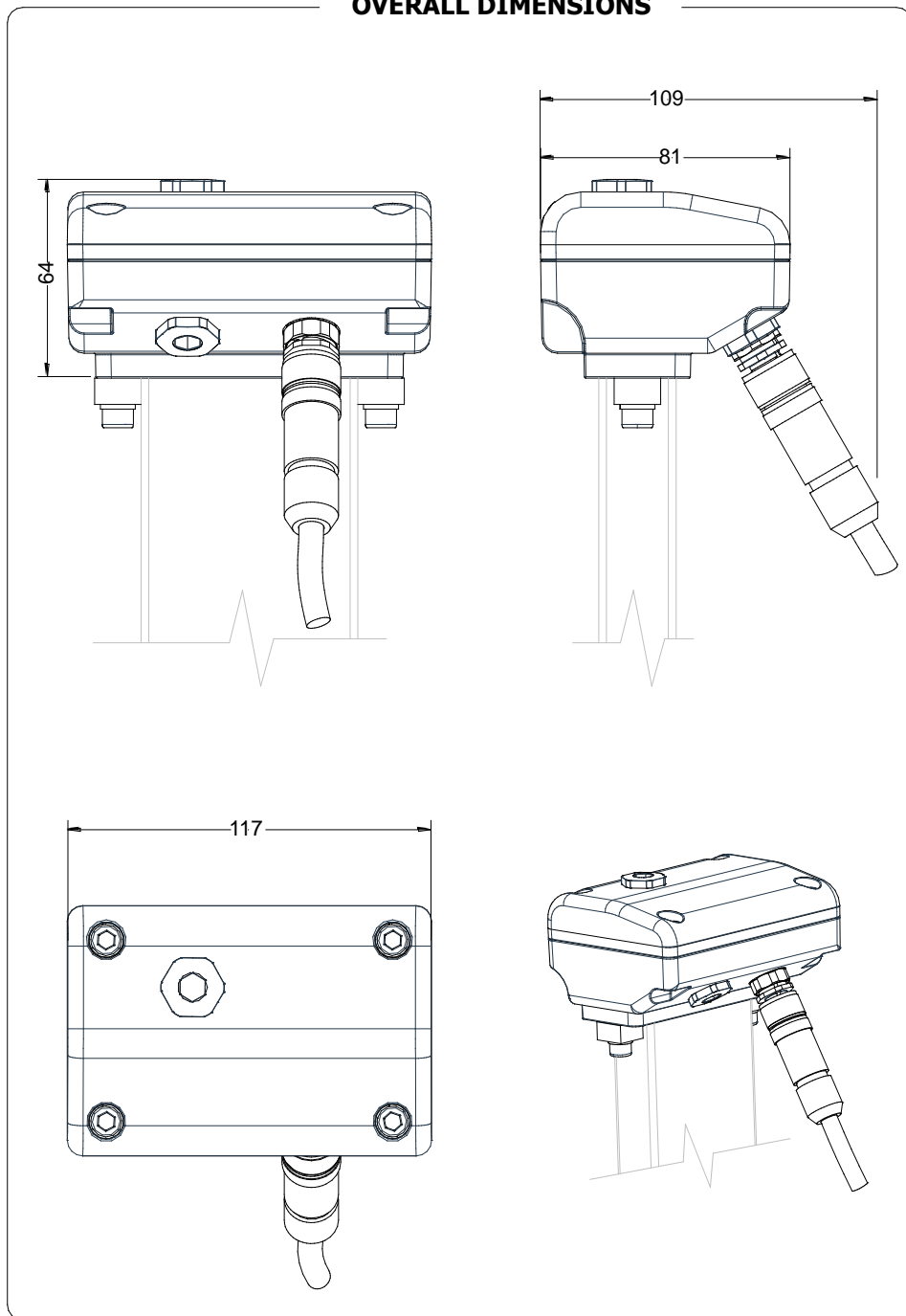

ELECTRICAL CONNECTIONS



GROUNDING

ALWAYS ensure that the instrument is grounded (earthed) correctly. The grounding ensures that the equipment and liquid are equipotential.

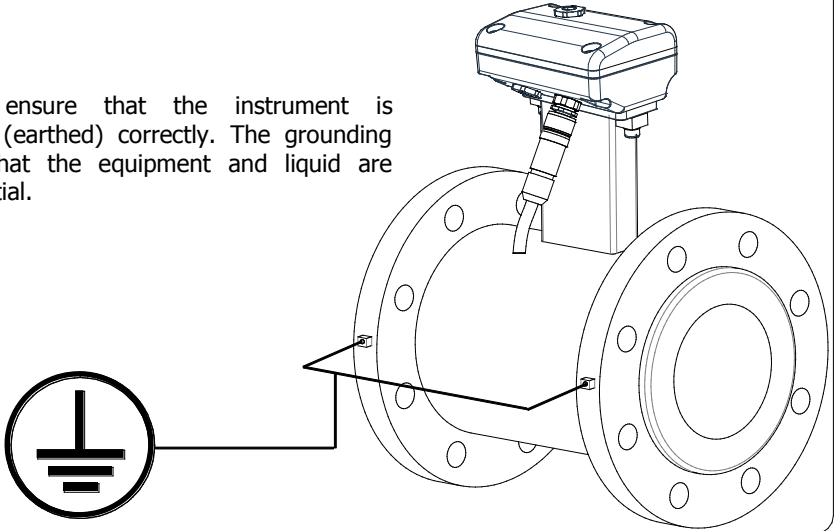

CONNECTOR

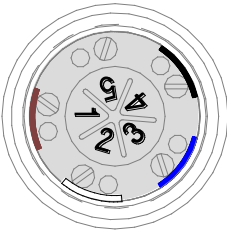

- 1 (+) POWER SUPPLY
- 2 (+) OUTPUT 1 / INPUT
- 3 (+) OUTPUT 2 (OPTIONAL)
- 4 (+) 4-20mA OUTPUT
- 5 (-) POWER SUPPLY / OUTPUTS / INPUT

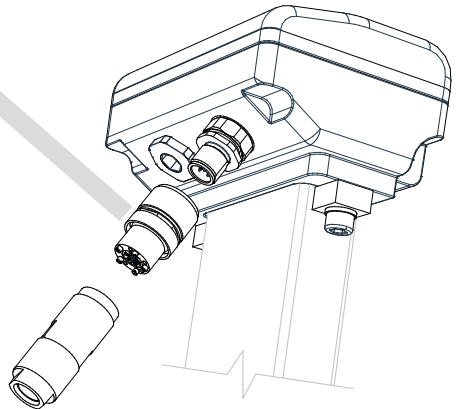



POWER SUPPLY

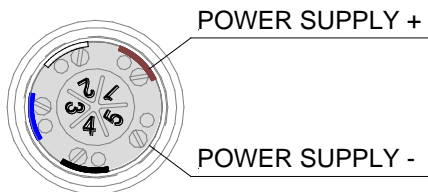

- ❑ Before connecting the power supply, verify that the mains voltage is within the limits indicated on data plate.
- ❑ For the connections use only approved conductors, with fire-proof properties, whose section varies from 0.25mm^2 to 2.50mm^2 , based on distance/power; additionally fix the power supply wires with a additional fastening system located close to the terminal.
- ❑ The power supply line must be equipped with an external protection for overload current (fuse or automatic line breaker).
- ❑ Provide in close proximity the converter a circuit breaker easily accessible for the operator and clearly identified; whose symbols must conform to the electrical safety and local electrical requirements.
- ❑ Ensure that the component complies with the requirements of the standard for electrical safety distance.
- ❑ Check chemical compatibility of materials used in the connection security systems in order to minimize electrochemical corrosion.

INPUT/OUTPUTS

OPERATION ON INPUT ON/OFF

Auto-calibration

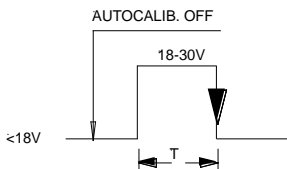

$T_{min} < T < 1sec.$ = autocalibration
 $T > 1 sec.$ = Auto zero

Necessary condition for enabling the function

POS. 5.6 ENABLED (Autozero calibration external command)

Reset totalizers

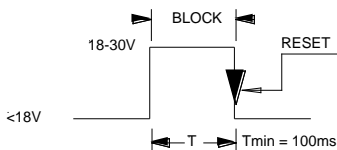

Necessary condition for enabling the function

POS. 5.1-4 ENABLED (partial, total, positive or reverse flow totalizers reset enable).

Block totalizers

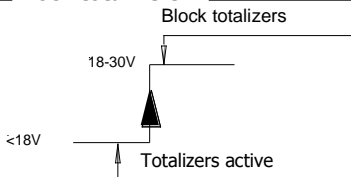

Necessary condition for enabling the function

POS. 5.5 ENABLED (totalizers counting lock command)

Measure lock

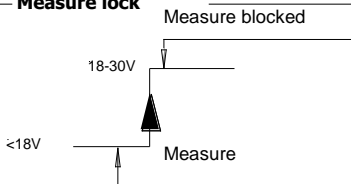

Necessary condition for enabling the function

POS. 5.6 ENABLED (measure lock)



FUNCTIONS ABOVE ARE ACTIVABLE ONLY WITH OUTPUT 1 OFF (pos. 6.1)

Speed rate

Tmin

Speed rate	Tmin
10Hz	220ms
20Hz	110ms
50Hz	45ms



ATTENTION: time T must be \geq Tmin

WIRINGS

Input on/off

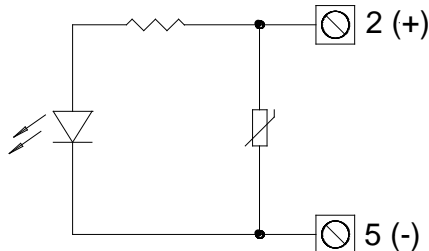

THE INPUT IS AVAILABLE IF PROPERLY SELECTED

- ❑ Insulation from other secondary circuits: 500V \approx
- ❑ Min voltage for logic "1": 18V \approx
- ❑ Max voltage: 30V \approx

Outputs on/off

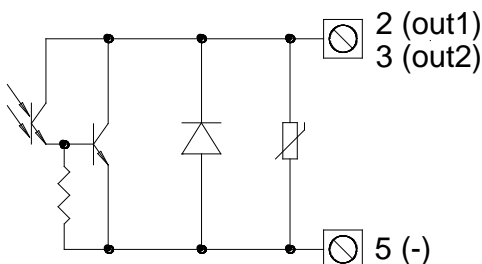

OUT 1 IS AVAILABLE IF PROPERLY SELECTED

- ❑ Opto-insulated output
- ❑ Maximum switching voltage: 40V \approx
- ❑ Maximum switching current: 100mA
- ❑ Maximum saturation voltage between collector and emitter @100mA: 1.2V
- ❑ Maximum switching frequency (load on the collector or emitter, $R_L=470\Omega$, $V_{OUT}=24V\approx$): 1250Hz
- ❑ Maximum reverse current bearable on the input during and accidental polarity reversion (VEC): 100mA
- ❑ Insulation from other secondary circuits: 500V \approx



– Output 2 (pos. 6.2) optional

4-20mA output (pos. 6.3-4) optional

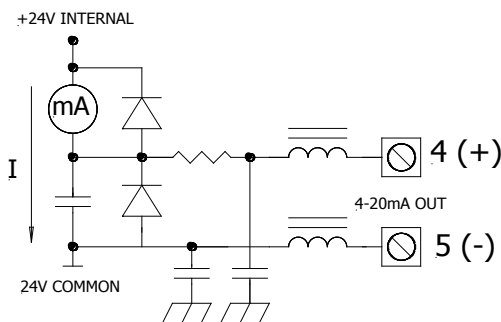

- ❑ Maximum load 1000 Ω @ 30V \approx
- ❑ Refresh frequency equal to the sample frequency
- ❑ Protected against persistent over voltages up to 30V \approx



NOTE: shielded cables are recommended for input and output wiring.

FLAGS AND LED INTERPRETATION

FLAGS

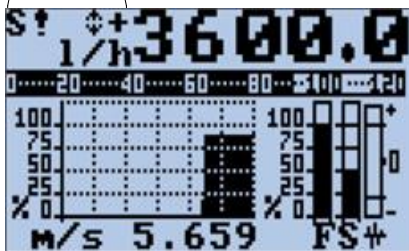

FLAGS INTERPRETATION	
FLAG	DESCRIPTION
◇	Alarm max/min activated
!	- Interruption coils circuit - Signal error - Empty pipe
C	Calibration running
S	Simulation
	Pulse output saturation (reduce TIME PULSE)

FLOW RATE VISUALIZATION

The instrument can show a 5 digit character display for flow rate units; this mean the maximum flow rate value that can be represented on the display is **99999** (no matter the positioning of the decimal point). The minimum is **0.0025**.

The representable measure unit depends from sensor diameter and flow rate; the permitted units are those, set the instrument full scale value, allow to be represented with a numerical field which the maximum value do not exceed **99999**.

Example for DN 10:

- Full scale value: 3m/s
- **PERMITTED** measure unit (example): l/s (0.2400); m³/h (0.8640); l/h (864.00)...
- **NOT PERMITTED** measure unit (example): m³/s (0.00024)...

ACCESS CODES

Functions in the converter main menu are enabled by the access codes. The information of this manual is related to all the functions available with the L2 level. All higher level functions are reserved for servicing and not available.

Description of the L2 access code

(menu "11 Internal data" pos. 11.1)

- with code L2 = 000000** (only with this code) you can disable the L2 code request
- * **with L2 customized** (freely chosen by the user) you can program all the functions up to L2 security level, entering this code whenever you enter the Main menu.

* **ATTENTION:** take careful note of the customized code you have chosen, there is no way for the user to retrieve or reset it if lost.

Factory preset access codes

The converter is delivered with the default L2 (level 2) access code:

111111

ACCESS TO THE CONFIGURATION MENU

The converter configuration menu can be accessed **ONLY** using the **ISOCON** interface (cable and software needed).

ISOCON INTERFACE

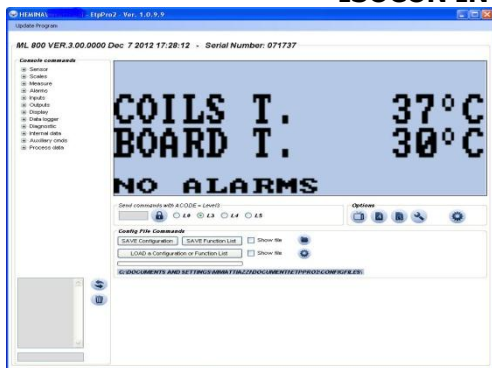

Isocon is a Windows® software that allows to set all the converter functions and personalize the menu (IF2X is required), see suitable manual for details.

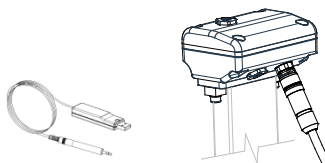

THE CONFIGURATION MENU

Functions can be accessed in two different ways:

- ❑ The **Quick start menu** makes direct access possible to a range of principal functions for setting the scale reading and display characteristics of the sensor.

```

0-QUICK START
Fsc=dm³/s 5.0000
Tot.MU= ml 1.000
Pls2= ml 1000.00
Tpls2=ms 0050.00
Damping= 0.2s
Main menu
  
```

Quick start menu can be enabled by function 8.3 (menu display)

Factory pre-setting: QUICK START MENU=ON

- ❑ Through the **Main menu** it is possible to access functions with the access code level 2. These control the sensor's monitoring, data processing, input/output as well further options.

```

MAIN MENU
1-Sensor
2-Scales
3-Measure
4-Alarms
5-Inputs
6-Outputs
8-Display
  
```

The examples on page 17 show how to change the Full scale by Quick Start menu and by the Main menu.

VISUALIZATION PAGES

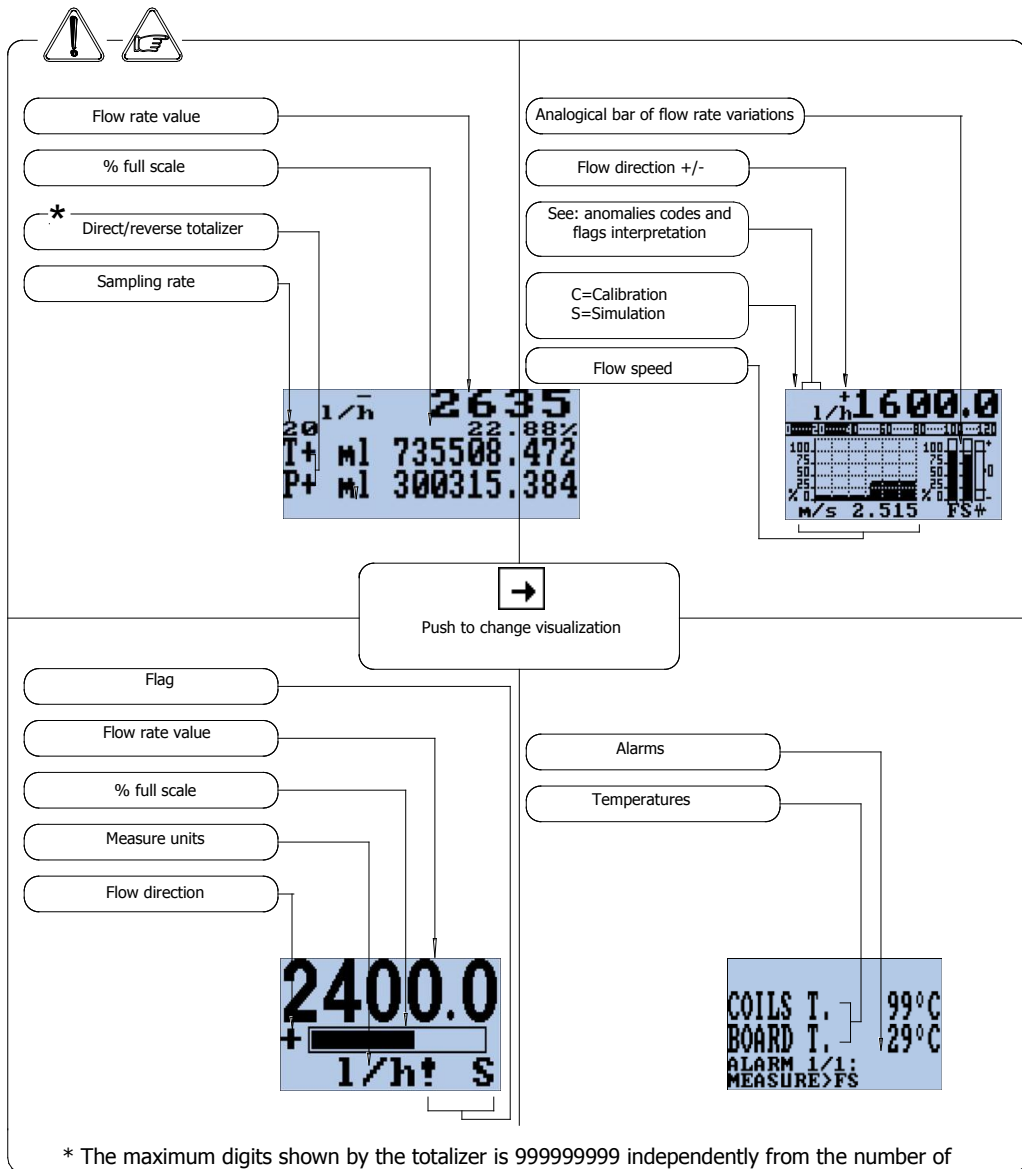

* The maximum digits shown by the totalizer is 999999999 independently from the number of selected decimals. Beyond this value the totalizers are reset.

QUICK START MENU

The user has immediate access to the Quick Start menu when the converter is powered up by pressing the key **Enter**. If access to the quick start menu does not occur, then it has been disabled through function 8.3

```
0-QUICK START
Fsc=dm³/h 018000
Tot.MU=dm³ 1.000
Pls1=dm³ 1.00000
Pls2=dm³ 1.00000
Tpls1=ms 0050.00
Tpls2=ms 0050.00
Damping= OFF
Main menu
```

See function menu section

Access to all functions

EXAMPLE: modifying the full scale value from $1\text{dm}^3/\text{s}$ to $2\text{dm}^3/\text{s}$, from the "Quick start menu"

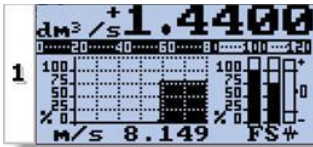

ent

Enter in the Quick start menu



ent

Access to the function "Fsc"

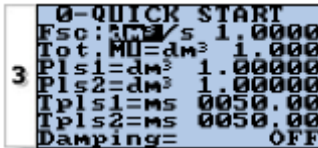

Push repeatedly

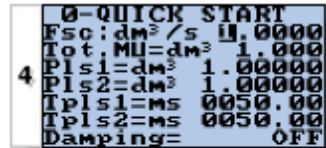

Change the value

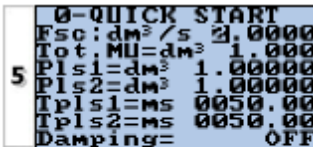

ent

Confirm the new value

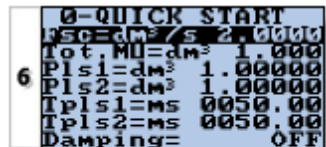

esc

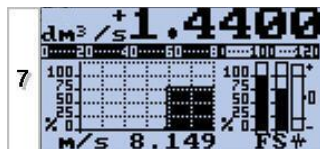

Main page

EXAMPLE: modifying the full scale value from 1dm³/s to 2dm³/s, from the "Main Menu" (quick start menu enabled)

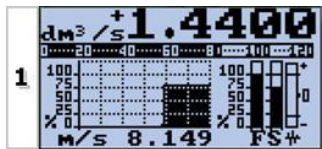

ent

Enter in the Quick start menu

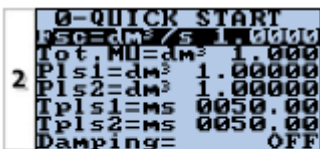

↑

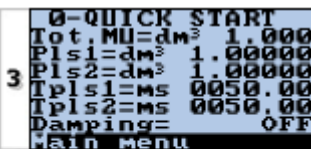

ent

Access to the Main Menu

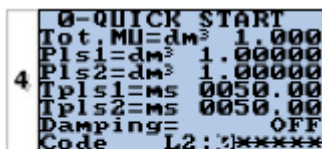

↑

→

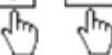

X 5 TIMES

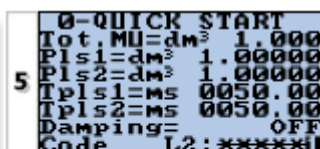

ent

Confirm the keycode



↓



ent

Access to the Scale menu

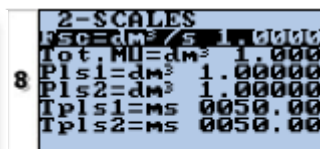

ent

Access to the function "Fsc"

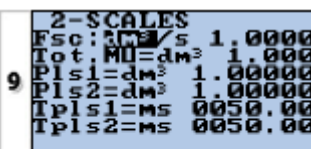

→

Push repeatedly

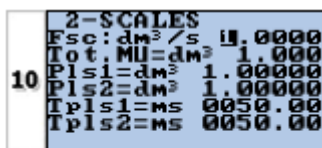

↑

Change the value

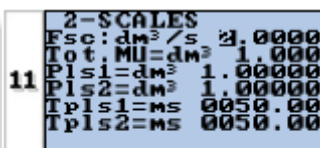

ent

Confirm the new value

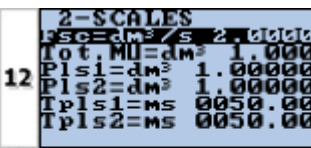

esc

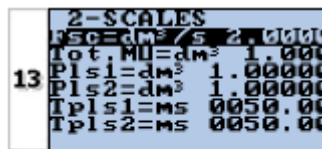

esc

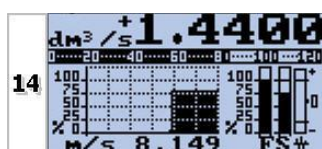

Main page

PROGRAMMING FUNCTIONS

(functions with access code < 3, those with symbol "*" see the next section)

Attention: The functions in grey colour are visualized on display only with other active functions or with optional modules

```

MAIN MENU
1-Sensor
2-Scales
1-SENSOR
ND=mm      00015
KA=        -01.4310
Sens.type= 018
E.P.detect= ON
E.cleaning= MAX
E.p.thr.=  200
1 Autozero cal.
1 Internal cal.
  
```

- 1.1 Sensor ND (10-15-20mm)
- 1.2 Sensor calibration data, visualized on sensor label
- 1.3 Sensor type: enter the first two characters of the sensor serial number
- 1.4 Enables the empty pipe detection feature
- 1.5* Electrodes cleaning
- 1.6* Value of empty pipe sensibility detection
- 1.7* Enables the automatic procedure of zero calibration

```

MAIN MENU
1-Sensor
2-Scales
2-SCALES
Fsc= l/h 1800.0
Tot.MU= ml 1.000
Pls1= ml 1000.00
Pls2= ml 1000.00
1 Ipls1=ms 0050.00
1 Ipls2=ms 0050.00
Sg=kg/dm³ 01.0000
  
```

- 2.1* Flow rate full scale value
- 2.2* Unit of measure and number of decimal place
- 2.3* Pulse value on channel 1
- 2.4* Pulse value on channel 2
- 2.5* Duration of the pulse generated on channel 1
- 2.6* Duration of the pulse generated on channel 2
- 2.7 Specific gravity set in kg/dm³

```

MAIN MENU
1-Sensor
2-Scales
3-Measure
3-MEASURE
Damping=   OFF
Cut-off=%  01.0
  
```

- 3.1* Measure filter
- 3.2 Low flow zero threshold: 0-25% of full scale value

```

2-Scales
3-Measure
4-alarms
4-ALARMS
Al.max+=%  000
Al.min+=%  000
Al.max-=%  025
Al.min-=%  025
1 Hyst.=%   01
1 mA v.fault=% 000
  
```

- 4.1 Maximum value alarm set for direct flow rate
- 4.2 Minimum value alarm set for direct flow rate
- 4.3 Maximum value alarm set for reverse flow rate
- 4.4 Minimum value alarm set for reverse flow rate
- 4.5 Hysteresis threshold set for the minimum and maximum flow rate alarms
- 4.6* Current output value in case of failure

3-Measure

4-Alarms

5-Inputs

5-INPUTS

T+ reset= OFF

P+ reset= ON

T- reset= OFF

P- reset= ON

Count lock= ON

Meas.lock= OFF

Calibration= OFF

- 5.1* Total direct (positive) flow totalizers reset enable
- 5.2* Partial direct (positive) flow totalizers reset enable
- 5.3* Total reverse (negative) flow totalizers reset enable
- 5.4* Partial reverse (negative) flow totalizers reset enable
- 5.5 Totalizers counting lock command (see page 9)
- 5.6* Block measures command
- 5.7* Autozero calibration external command

4-Alarms

5-Inputs

6-Outputs

6-OUTPUTS

Out1= OFF

Out2= PLS+

Out mA=4÷22

Out mA= FLOW

- 6.1* Output 1 functions
- 6.2* Output 2 functions
- 6.3* Choice of the current output range
- 6.4 Choice of the current output function: flow rate

5-Inputs

6-Outputs

8-Display

8-DISPLAY

Language= EN

D.rate=Hz 5

Quick start= OFF

T+ reset

P+ reset

T- reset

P- reset

- 8.1 Choice of the language: EN= English, IT=Italian, FR= French, SP= Spanish
- 8.2 Display updating frequency: 1-2-5-10 Hz
- 8.3 Quick start menu visualization
- 8.4* Total direct (positive) flow totalizer reset
- 8.5* Partial direct (positive) flow totalizer reset
- 8.6* Total reverse (negative) flow totalizer reset
- 8.7* Partial reverse (negative) flow totalizer reset

6-Outputs

8-Display

9-Data logger

9-DATA LOGGER

Disp.min/max

Reset min/max

- 9.1 Visualization function of minimum and maximum flow rate values
- 9.2 Immediate reset all minimum and maximum flow rate values stored

8-Display

9-Data logger

10-Diagnostic

10-DIAGNOSTIC

Calibration

Self test

Simulation= OFF

Firmware rev.

- 10.1* immediate calibration of the instrument
- 10.2* Immediate autotest of the instrument
- 10.3* Flow rate simulation enabling
- 10.4 Visualize firmware revision/version

9-Data logger

10-Diagnostic

11-Internal data

11-INTERNAL DATA

L2 code= *****

Load fact.pres.

KR= +1.0000

KS= +1.0000

- 11.1 Level 2 access code enter
- 11.2 Immediate Re-Load of the pre-set factory data
- 11.3 KR coefficient (only for service purposes)
- 11.4 KS coefficient (only for service purposes)

FUNCTIONS DESCRIPTION

(description of the functions with access code < 3)

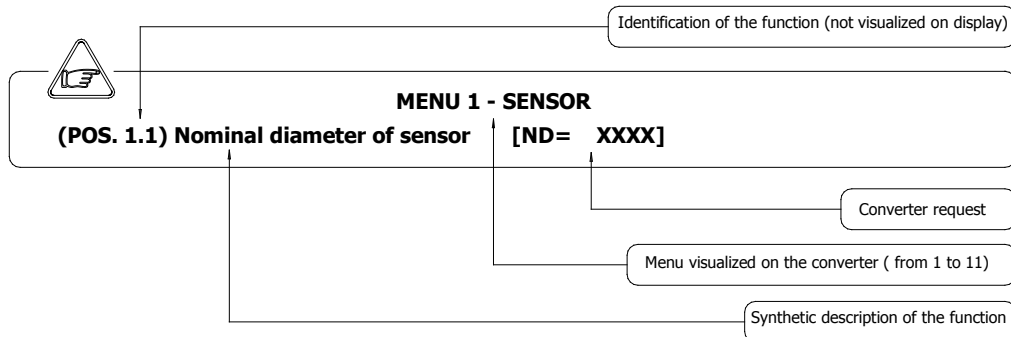

The following pages give a description of the most important functions and how they can be changed or enabled/disabled by the user

MENU 1 - SENSOR

(POS. 1.5) Electrodes cleaning

Selectable options: OFF, minimum, average and maximum. The use of this function is not recommended (set OFF) when the liquid has a conductivity less than $20\mu\text{S}/\text{cm}$.

[El. Cleaning=MIN]

(POS. 1.6) Empty pipe threshold

This value represents the threshold to block the measure to zero in the empty pipe condition; the function span is 20-250. Since the sensibility of empty pipe detection could vary due to the liquid conductivity, ground connections, type of lining. If required the preset threshold can be adjusted manually. It is recommended to check periodically its proper functioning. Value increasing means sensibility decreasing.

[E.p. thr.=XXX]

(POS. 1.7) Autozero calibration

This function activates the automatic zero calibration of the system. To perform this operation, it is necessary for the sensor to be full of liquid, and the liquid be perfectly still. Even minimal movement of the liquid may affect the result, and consequently, the accuracy of the system. Once you are sure the above conditions have been fulfilled (and the percentage flow rate value is stable) press the key \downarrow automatically activating the zeroing procedure, after which it is necessary to check that the percentage value showed goes to zero, repeat the operation if required. When the value is stable at zero, then press the key **Enter**.

[Autozero cal.]

MENU 2 - SCALES

(POS. 2.1) Flow rate full scale

The full scale is used to indicate the meter's maximum flow rate; a volume per time is required. The full scale should be chosen carefully as it's parameters are used for several other parameters. There are four fields to fill in order to set this parameter, from left to right: 1) volume unit of measure, 2) type of unit, 3) time unit of measure and 4) numeric value. The selection is made by positioning the cursor on the field to modify. To change the type of unit of measure (metric, British or American, mass or volume) the cursor has to be positioned on the symbol "/" (field N. 2). When the nominal diameter is set to zero it is possible to modify only the numeric field, since the unit of measure stays at m/sec. The following tables show the units of measure available and the conversion factor by comparison with 1dm^3 and 1kg. The instrument accepts any kind of combination of units of measure satisfying both the following conditions:

[Fsc= $\text{dm}^3/\text{SX.XXXX}$]

- Numeric field value ≤ 99999
- $1/25 f_{\text{Smax}} \leq \text{numeric field value} \leq f_{\text{Smax}}$.

where $f_{s_{max}}$ is the maximum full scale value corresponding to the sensor, equal to a 10m/s liquid speed. The measure units are shown as appear on the display. The British and American units are diversified by using capital and small characters.

cm³	Cubic centimetre
ml	Millilitre
l	Liter
dm³	Cubic decimeter
dal	Decalitre
hl	Hectolitre
m³	Cubic metre

in³	Cubic inch
Gal	American gallon
GAL	British gallon
ft³	Cubic foot
Bbl	Standard barrel
BBL	Oil barrel
yd³	Cubic yard
kgl	KAmerican gallon
KGL	KBritish gallon

G	Gram
Kg	Kilogram
T	Ton

Oz	Ounce
Lb	Pound
Ton	short tons

When a mass unit of measure is set, the specific gravity function is automatically enabled by the system. Please, note that the mass measure is heavily affected by the temperature. With certain liquids this may cause significant measurement errors. The following measure of time units can be selected: **s** = second, **m** = minute, **h** = hour, **d** = day.

(POS. 2.2) Measure unit and decimal totalizers number **[Tot.MU=dm³X.XXX]**

Setting the measure unit and number of decimals for visualized totalizers or the volumes to batch. Setting the measure unit and the number of decimals places displayed for the volumes. To set the measure unit, position the cursor on field of the measure unit. To set the unit type, position the cursor on the blank space between the measure unit and the numeric value; the number decimal places can be selected by placing the cursor on numeric field and choosing one of the possible combinations: 1000-01.00-001.0-00001.

(POS. 2.3-4) Pulse value channel 1-2 and unit of measure of tot. **[Pls1-2=dm³X.XXXXX]**

This function allows the user to set a signal (a pulse) to be given from the converter when a defined amount of liquid has passed through the sensor. To set the parameter, complete the three fields, from left to right: 1) measure unit, 2) unit type and 3) numeric value. The selection is performed by positioning the cursor in the field to be modified. To change the unit type (metric, British or American, mass or volume) position the cursor on the blank space between the measure unit and the numeric value. When the nominal diameter is set to zero it is possible to modify only the numeric field since the measure unit stays at meters (m) or feet (ft). Only those units described above are available to be selected.

(POS. 2.5-6) Pulse duration channel 1-2 **[Tpls1-2=msXXXX.XX]**

With the liquid volume to generate the pulse value set by the user. The user must set the corresponding duration of the pulse to be outputted. This value is expressed in milliseconds and has to be between 0.4 and 9999.99. When the high frequency output is present, then the minimum value can type of device is connected to the converter, the user must verify that the set pulse duration is compatible with the external device processing such pulses. If, for example, an electro-mechanical pulse counter is connected, one of be set to a minimum of 0.4 milliseconds. ATTENTION: since the converter can not detect which two problems may occur; firstly, if the pulse is too long the coils may burn out, secondly, if the pulse is too short, the counter may not be able to function, with the possibility of causing damage of the output

MENU 3 - MEASURE

(POS. 3.1) Damping**[Damping=OFF/SMARTX/(time)]**

This section of the manual is extremely important because the right settings of filters allow to get a proper response of the instrument to the measured flow rate. The available filter values are in the range between null damping(damping=OFF) and maximum damping (damping=1000s.)

Next picture show the instrument behavior with flow rate change in or range 1-100% at different damping settings.

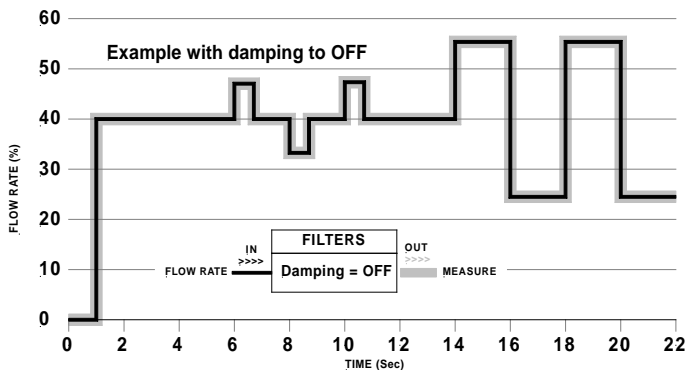

Damping function(OFF) extent follows the trend of fast flow

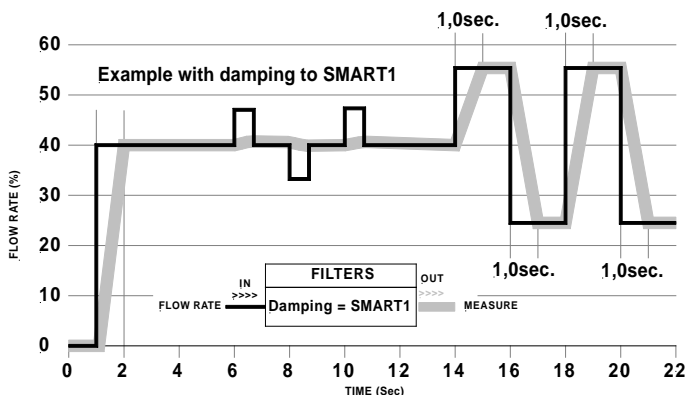

Damping(Smart 1,2,4):this does something effective filter measure noise and the sudden change in flow rate is measured by how smart damping parameter on the rise.

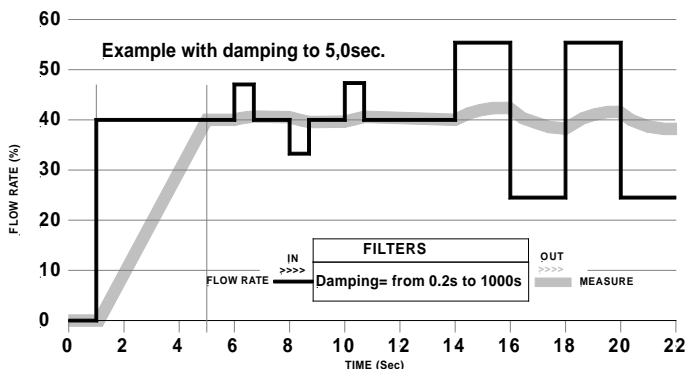

Damping mode based on time (from 0.2s to 1000s) The measure is average over a number of samples determined by the value assigned to the function. When the damping parameter is expressed in seconds, the filter works damping the measurement noise and sudden change of flow rate. Increasing the parameter of damping increase the stability of the measurement.

MENU 4 - ALARMS

(POS. 4.8) Current output value in case of failure**[mA v.fault =% XXX]**

The output current signal can be specified by the user due to Empty Pipe or failure of either, coils interrupted, or ADC error. The signal current is set as a percentage (0 to 120%) of the 0/4-20mA current. 120% corresponds to 24mA and does not depend on the selected range (0-20/4-20mA).

The NAMUR NE43 recommendation asks for a alarms signalling value for the current output lower than 3.6mA (<18%) or bigger than 21mA (>105%). It would then be preferable to set the value of this function at the 10%, so that the current value in case of the a.m. cases would be 2 mA, allowing the following diagnostics:

- current < 2mA - 5%: line interrupted, power supply failure or faulty converter;
- 2mA -5% ≤ current ≤ 2mA + 5%: hardware alarm;
- 4mA ≤ current ≤ 20mA: normal working range;
- 20mA < current ≤ 22mA: out of range, measure above 100% f.s.

Note: Setting this parameter to zero disables the alarm

MENU 5 - INPUTS

(POS. 5.1-4) Reset totalizer enable**[T/P+/- reset=ON/OFF]**

When the specified function is enabled, the related totalizer may be reset through the on/off input.

(POS. 5.6) "Block measures" command block measures enable**[Meas. lock=ON/OFF]**

When this function is active (ON), applying a voltage on the on input terminals, the measurement is stopped, the meter will display zero flow.

(POS. 5.7) "Autozero" calibration external command enable**[Calibration=ON/OFF]**

When this function is active, applying a voltage on the on/off input terminals the meter performs a autozero calibration cycle. ATTENTION: If the voltage pulse is less than 1 sec., the meter performs a calibration cycle to compensate for possible thermal drifts. If the voltage pulse is more 1 sec, the meter performs a zero calibration measure. This function enables/disables the automatic zero calibration of the system. To perform the calibration it is absolutely necessary for the sensor to be full of liquid and that the liquid is perfectly still. Even very small movement of the liquid may affect the result of the calibration, and, consequently, the accuracy of the system.

MENU 6 - OUTPUTS

(POS. 6.1-2) Function corresponding to on/off output 1-2**[OUT1-2=XXXXXX]**

Choice of the function corresponding to digital outputs. The functions are listed in the table below.

FUNCTIONS ASSOCIATED TO THE OUTPUTS 1 AND 2

OFF: DISABLED
 PLS+: PULSE FOR POSITIVE FLOW RATE
 PLS-: PULSE FOR NEGATIVE FLOW RATE
 PLS: PULSE FOR POSITIVE AND NEGATIVE FLOW RATE
 SIGN: LOW DIRECTION OUTPUT (ENERGIZED=-)
 MAX Q.AL.: MAX FLOW RATE OUTPUT(ENERGIZED = AL. OFF)
 MIN Q.AL.: MIN FLOW RATE OUTPUT(ENERGIZED = AL. OFF)
 MX+MX Q.: MAX AND MIN FLOW RATE OUTPUT(ENERGIZED = AL. OFF)
 P. EMPTY: EMPTY PIPE ALARM OUTPUT (ENERGIZED = FULL PIPE)
 OVERFLOW: OUT OF RANGE ALARM OUTPUT (ENERGIZED = FLOW RATE OK)
 HARDW AL.: CUMULATIVE ALARM OUTPUT interrupt coils, empty pipe, measure error (ENERGIZED = NO ALARMS)

(POS. 6.3) Function and the range of current output**[Out mA=X÷XX+]**

The function associated to the signal current on output. The current output N.1 is **optional and it is mounted on the main board**. There are three fields to modify for this function:

- Scale zero: **4** or **0**mA;
- Full scale: **20** or **22**mA
- Field: **+** = positive, **-** = negative, blank = both, **-0+** = central zero scale

The values corresponding to the scale points are shown in the following chart:

POSSIBLE FIELD	CURRENT VALUES IN mA ASSOCIATE TO THE % VALUE OF FULL SCALE				
	REVERSE FLOW VALUE		ZERO	DIRECT FLOW	
	≤ -110%	-100%	0%	+100%	≥ +110%
OutmA = 0 ÷ 20 +	0	0	0	20	20
OutmA = 0 ÷ 22 +	0	0	0	20	22
OutmA = 4 ÷ 20 +	4	4	4	20	20
* OutmA = 4 ÷ 22 +	4	4	4	20	22
OutmA = 0 ÷ 20 -	20	20	0	0	0
OutmA = 0 ÷ 22 -	22	20	0	0	0
OutmA = 4 ÷ 20 -	20	20	4	4	4
OutmA = 4 ÷ 22 -	22	20	4	4	4
OutmA = 0 ÷ 20	20	20	0	20	20
OutmA = 0 ÷ 22	22	20	0	20	22
OutmA = 4 ÷ 20	20	20	4	20	20
OutmA = 4 ÷ 22	22	20	4	20	22
OutmA = 0 ÷ 20 -0+	0	0	10	20	20
OutmA = 0 ÷ 22 -0+	0	1	11	21	22
** OutmA = 4 ÷ 20 -0+	4	4	12	20	20
OutmA = 4 ÷ 22 -0+	4	4.8	12.8	20.8	22

In hardware alarm conditions "HARDW AL." (interrupted coils, empty pipe, measure error) the current value is programmed by the function "mA v.fault" (pos. 4.8) and it is expressed as percentage of a fixed current range, where: 0% = 0mA and 110% = 22mA.

* Example 1: out 4-22 +

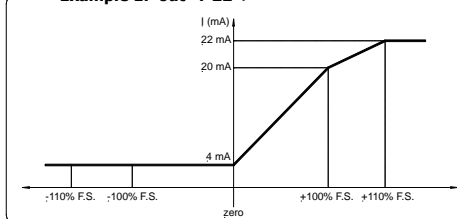

** Example 2: out 4-20 -0+

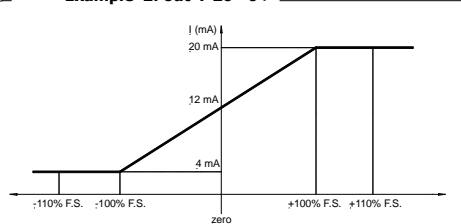

MENU 8 - DISPLAY

(POS. 8.4-7) Total/partial totalizers reset

[T/P/-/+ reset]

Activates the reset of total and partial flow totalizer. These functions are activated by pressing the key **Enter** during the visualization of the function itself. When "EXECUTE?" is required, press long **Enter** to proceed. Press any other key to delete the operation.

MENU 10 - DIAGNOSTIC

(POS. 10.1) Meter calibration

[Calibration]

Enables the calibration of the meter. The activation of this function happens pressing the key **Enter** during the visualization of the function. The following message will be visualised on the screen: "EXECUTE?" press long the key **Enter** to proceed. Press any other key to delete the operation. The liquid must be absolutely still during the calibration.

(POS. 10.2) Autotest function

[Self test]

Meter autotest function. This function stops the normal functions of the meter and performs a complete test cycle on the measure input circuits and on the excitation generator. To activate this function, after select it, push key **Enter**, at the question: "EXECUTE?" push long the same key for start autotest, or any other key for delete operation. The result of the test is shown on the display. At the end of operation the converter will revert to one of the initial visualization pages. This function is automatically performed when switching on the device.

(POS. 10.3) Flow rate simulation

[Simulation=ON/OFF]

Flow rate simulation enabling. With this function it is possible to generate an internal signal that simulates the flow rate, allowing the test of outputs and all the connected instruments. After enabling it, a 'S' appears in the top left of the screen and the flow rate simulation can be:

- set: by pushing the key **Enter** from one of visualization pages, to set the required % flow rate (Fl.rate=%) and the same key to confirm the value;
- finished: by pushing the key **Enter** from visualization pages and then by long pushing the same key.

ALARM MESSAGES

CAUSES AND ACTIONS TO BE TAKEN

Messages	ANOMALIES	ACTION TO TAKE
NO ALARMS	All works regularly	-----
EXC.FREQ.ERR.	The coils or the cable connecting the sensor are interrupted	Check the status of the cables connecting the sensor to the converter
MAX FLOW ALARM	The flow rate is higher than the maximum threshold set	Check the maximum flow rate threshold set and the process conditions
MIN FLOW ALARM	The flow rate is lower than the minimum threshold set	Check the minimum flow rate threshold set and the process conditions
MEASURE>FS	The flow rate is higher than the full scale value set on the instrument	Check the full scale value set on the instrument and the process conditions
PULSE/FREQ>FS	The pulse generation output of the device is saturated and cannot generate the sufficient number of impulses	Set a bigger unit of volume or, if the connected counting device allows it, reduce the pulse duration value
INPUT NOISY	The measure is strongly effected by external noise or the cable connecting the converter to the sensor is broken	Check the status of the cables connecting the sensor, the grounding connections of the devices and the possible presence of noise sources
EMPTY PIPE	The measuring pipe is empty or the detection system has not been properly calibrated	Check whether the pipe is empty or repeat the empty pipe calibration procedure
EXCITATION FAIL	The coils or the cable connecting the sensor are interrupted	Check the connecting cables to the sensor
B.TEMP.>LIMITS	The measured board temperature is out of the allowed range	Ensure that the instrument is operating within the specified temperature conditions
SENS.T.>LIMITS	The measured sensor temperature is out of the allowed range	Ensure that the instrument is operating within the specified temperature conditions
TEMP.SENS.ERR	The external temperature sensor is not working properly	Check the external temperature sensor and its connections
CALIBRATION	Internal calibration error	If the error is persistent, replace the board

ANOMALIES CODES

CODES	ANOMALIE DESCRIPTIONS	ACTION TO TAKE
0000	No anomalies	ADDRESSING TO SERVICE
0002	Factory data not valid	
0004	Work data not valid	
0008	F-RAM writing/reading error	
0076	Power supply error	
0400	Gain input stage is out of range	Check the status of the cables connecting the sensor to the converter, the grounding connections of the devices or the possible presence of strong and anomalous noise sources
0800	Interruption on the coils circuit	Check the status of the cables connecting the sensor to the converter

SERVICE: return form for instrument repair or calibration

ISOMAG RETURN MATERIAL FORM AND CLEANING UP CERTIFICATE RMA
n° _____

Shipping Address:

ISOIL INDUSTRIA S.p.A.
Via Piemonte, 1
35044 MONTAGNANA (Padova)
Italy

Dear Friend,

to improve the SERVICE QUALITY and the SAFETY, please read, complete and attach this document (RMA) to the material you intend to send. Failure in RMA compilation will not allow us to be able to take charge of the materials.

Sender: _____ **Ref. D.D.T. n.** _____ **of** ____/____/_____

- A detailed set of instructions for testing the sensor isolation and continuity is given in the service manual. If you are experiencing problems that are not related to the physical integrity of the sensor (water ingress, body, liner, connector or electrodes damage for example) we kindly ask you to test the sensors isolation and continuity. If the sensor passes these tests then we ask you to consider not returning this sensor without first consulting isomagservice@isoil.it
- In the case that the instrument is returned and it is not repairable inside the warranty agreement terms or the inspection report is not accepted a cost for any converter testing and sensor dry testing and inspection will be mandatorily debited.
- Please send the sensor clean from medium. Additionally please inform about eventual medium wastes remaining in the body. For this purpose please use this form.
- A safety specification sheet of the medium must accompany this repair note in the following cases: toxic, otherwise dangerous or objectionable medium, or medium belonging to any dangerous material class.
- Please note that the instruments sender will be charged for any necessary cleaning costs. Additionally, we reserve the right to send the instruments back to the sender for cleaning!
- Please kindly state the observed failure and, eventual causes.

Electromagnetic flow meter: ML 800

Serial number: _____

Failure description: _____

We herewith confirm that above mentioned sensor has been cleaned and it is therefore free of any liquid and/or solid wastes of the measuring medium and/or cleaning medium. Any eventually remaining wastes are:

Measuring medium: _____

**harmful/
injurious**

no

**yes; in this case, safety specification
sheet must be attached!**

Sensor cleaned with: _____

Further notes: _____

Date

Company stamp

e-mail address (for questions)

Signature of person in charge

CONFORMITY DECLARATION

Isoil Industria spa

Declares that the product line:

ISOMAG ™

Electromagnetic flow meter model:

ML 800

to which this declaration refers, are in compliance with the following Harmonized European Norms:

- **EN 61010-1:2010**
- **EN 61326-1:2006**

and therefore comply to the following CE requirement directives:

- **2006/95/CE (Low voltage directive – LVD)**
- **2004/108/CE (Electromagnetic compatibility Directive – EMC)**

06/02/2012

THE LEGAL REPRESENTATIVE

ISOIL 
INDUSTRIA

via F.lli Gracchi, 27 20092 Cinisello Balsamo (MI)
Tel. +39-02-660271
Fax +39-02-6123202

ADDRESSES

Isoil Industria spa

Head office
20092 Cinisello Balsamo (MI) Italy
27, via F.lli Gracchi
Phone +39-02-66027.1
Fax +39-02-6123202
E-mail: sales@isoil.it
Web: www.isoil.com

Service

Isoil Industria spa

20092 Cinisello Balsamo (MI) Italy
27, via F.lli Gracchi
Phone +39-02-66027.1
Fax +39-02-6123202
E-mail: isomagservice@isoil.it



North America Distribution:



FLOMOTION SYSTEMS Inc.
3 N. Main St, Middleport, NY 14105
Toll Free: (800)909-3569 (U.S. & Canada)
Tel: (716)691-3941 ~ Fax: (716)691-1253
info@flomotionsystems.com
www.FlomotionSystems.com