

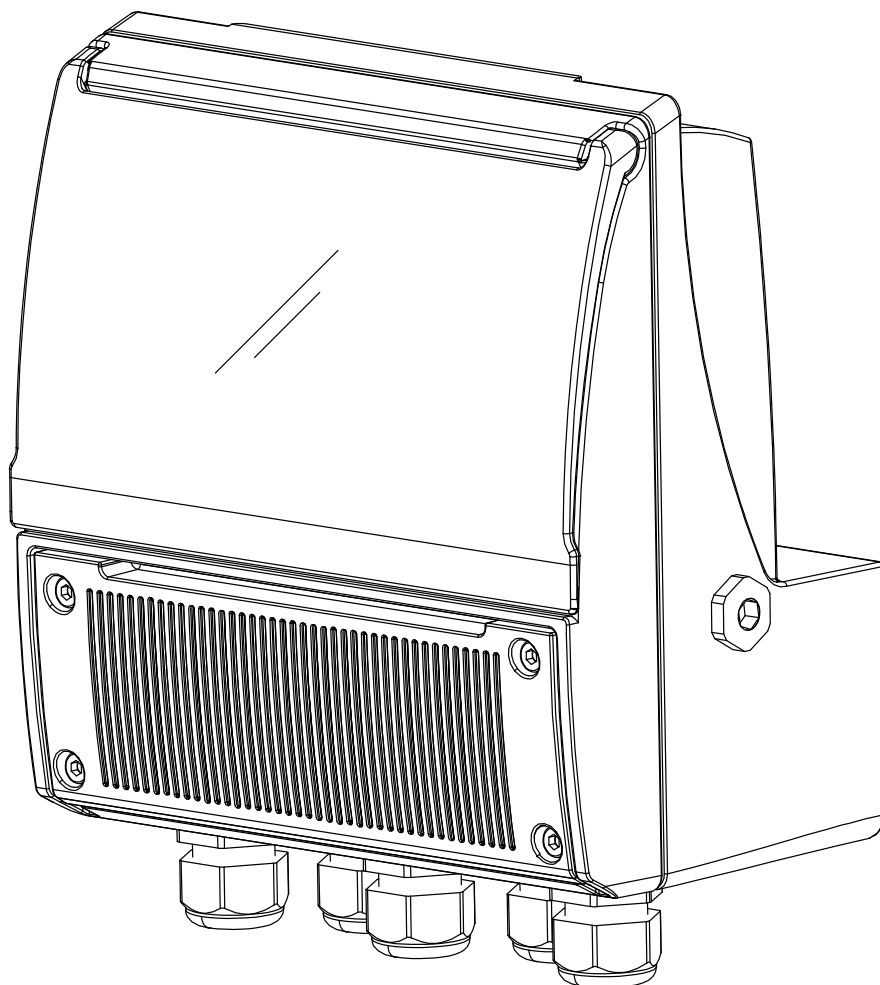

**ISOMAG** 

*The friendly magmeter*

**OPERATING AND MAINTENANCE  
MANUAL**



**MV110**

**CE**

**ISOIL**   
I N D U S T R I A



Release number: **MAN\_MV110\_EN\_IT\_IS\_R19\_1.05.XXXX**

The characters of file name in bold type indicate the software version which the manual refers to; it is visualized at the instrument start up, or by specific function on DIAGNOSTIC menu.



**INDEX**

INTRODUCTION	3
SAFETY INFORMATION	3
SAFETY CONVENTION	4
TECHNICAL CHARACTERISTICS	5
DIMENSIONS (PLASTIC AND ALUMINIUM VERSIONS)	7
DIMENSIONS (STAINLESS STEEL VERSION)	10
TORQUES	12
MV110 CONSTRUCTION (ALUMINIUM AND PA6 VERSIONS)	14
MV110 CONSTRUCTION (STAINLESS STEEL VERSION)	15
INTERNAL LAYOUT	16
ELECTRICAL CONNECTION AND GROUNDING INSTRUCTIONS	17
INTERNAL LITHIUM BATTERY	18
ELECTRICAL CONNECTION CONVERTER- SENSOR	20
DIGITAL INPUT ON/OFF OPERATION	21
OUTPUTS WIRING	22
RS485 MODBUS MODULE (OPTIONAL)	23
CONNECTORS MIL	24
START VISUALIZATION PAGES	25
MEANING OF FLAGS	27
MEANING OF LED COLORS	27
ACCESS TO THE CONFIGURATION MENU	28
ACCESS VIA MCP INTERFACE (VIRTUAL DISPLAY)	29
FLOW RATE VISUALIZATION	30
QUICK START MENU	30
CONVERTER ACCESS CODE	31
FUNCTIONS MENU	34
FUNCTIONS DESCRIPTION	39
MENU 1 - SENSOR	40

MENU 2 - UNITS	44
MENU 3 - SCALE	46
MENU 4 - MEASURE	48
MENU 5 - ALARMS	50
MENU 6 - INPUTS	51
MENU 7 - OUTPUTS	52
MENU 8 - COMMUNICATION	54
MENU 9 - DISPLAY	55
MENU 10 - DATA LOGGER	56
USING DATA LOGGER BY MCP INTERFACE	58
MENU 11 - FUNCTION	63
MENU 12 - DIAGNOSTIC	64
MENU 13 - SYSTEM	67
MENU 14 - FILE (ONLY MCP)	73
MENU 15 - PROCESS DATA (ONLY MCP)	74
METER DATA	77
OPERATING PROCEDURE TO CHANGE THE CONVERTER BOARD	78
B.I.V. (BUILT-IN VERIFICATOR)	79
SOFTWARE ISOBIV	82
ALARM MESSAGES (CAUSES AND ACTIONS TO BE TAKEN)	83
ERROR CODE TEST SYSTEM OF SENSOR	85
MANUAL REVIEWS	88

## INTRODUCTION

These operating instructions and description of device functions are provided as part of the scope of supply.

They could be modified without prior notice. The improper use, possible tampering of the instrument or parts of it and substitutions of any components not original, renders the warranty automatically void.

The flow meter realizes a measure with liquids of conductivity greater than  $5\mu\text{S}/\text{cm}$  in closed conduits, and is composed of a converter (described in this manual) and a sensor (refer to the specific manual).

The converter could be coupled directly on the sensor (compact version) or coupled to the sensor by cable supplied with it (remote version).

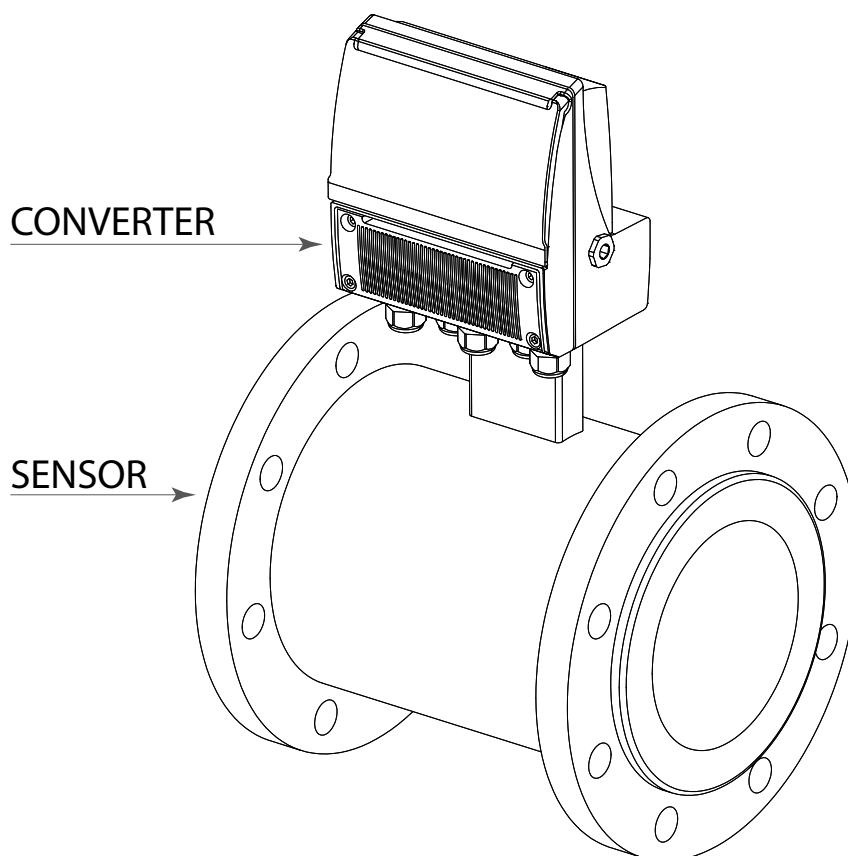

## SAFETY INFORMATION

- ❑ Any use other than described in this manual affects the protection provided by the manufacturer and compromises the safety of people and the entire measuring system and is, therefore, not permitted. The manufacturer is not liable for damaged caused by improper or non-designated use.
- ❑ Transport the measuring device to the measuring point in the original packaging. Do not remove covers or caps until immediately before installation. In case of cartons packaging it is possible to place one above the other but no more than three cartons. In case of wooden packaging do not place one above the other.
- ❑ Disposal of this product or parts of it must be carried out according to the local public or private waste collection service regulations.
- ❑ The converter must only be installed, connected and maintained by qualified and authorized specialists (e.g. electrical technicians) in full compliance with the instructions in this Operating Instruction, the applicable norms, legal regulations and certificates (depending on the application).
- ❑ The specialists must have read and understood these Operating Instructions and must follow the instructions it contains. The Operating Instructions provide detailed information about the converter. If you are unclear on anything in these Operating Instructions, you must call the ISOIL service department.

- The converter should only be installed after have verified technical data provided in these operating instructions and on the data plate.
- Specialists must take care during installation and use personal protective equipment as provided by any related security plan or risk assessment.
- Never mount or wire the converter while it is connected to the power supply and avoid any liquid contact with the instrument's internal components. To connect remove the terminals from the terminal block.
- Before connecting the power supply check the functionality of the safety equipment.
- Each part of the instrument must be examined or supplied exclusively by the manufacturer or his representative
- Repairs may only be performed if a genuine spare parts kit is available and this repair work is expressly permitted.
- For the cleaning of the device use only a damp cloth.
- If the instrument is used in a another way than the one specified by the manufacturer, the protection provided by the device may be compromised.

**Before starting up the equipment please verify the following:**

- Power supply voltage must correspond to that specified on the data plate
- Electric connections must be completed as described
- Ground (earth) connections must be completed as specified

**Verify periodically (every 3-4 months):**

- The power supply cables integrity, wiring and other connected electrical parts
- The converter housing integrity
- The suitable tightness of the sealing elements
- The front panel integrity (display and keyboard)
- The mechanical fixing of the converter to the pipe or wall stand

**SAFETY CONVENTION**

 <b>DANGER ELECTRIC SHOCK</b>	 <b>WARNING</b>	 <b>PRECAUTIONS</b>	 <b>ATTENTION</b>
---	---	--	---

The manufacturer guarantees only English text available on our web site: www.isoil.com

# TECHNICAL CHARACTERISTICS

## Electrical Characteristic



Converter classification: class I,  
 IP67 (where: 6 = totally protected against dust, 7 = Protected against the effects of temporary immersion) /  
 IP68 (where: 6 = totally protected against dust, 8 = continuous immersion 1.5 m; 1 h)  
 for aluminum and PA6 housing, installation category (overvoltage) II, rated pollution degree 2.

Power supply versions	Power supply voltage	Power supply frequency	Min Power	Max power
HV	100-240V~	45-66HZ	1,5 W (Sensor only)	12 W (all Loads)
LV	24-36V ---	//		
	24-36V~	45-66HZ		
LLV	12-48V ---	//		

- Voltage variations must not exceed  $\pm 10\%$  of the nominal one.
- Input/output are insulated
- The output 4-20mA (optional) is electrically connected to the ON/OFF outputs and the output power supply (24V ---).
- Version LV/LLV : inrush current < 20A  
Version HV : inrush current < 25A

**Note:** The devices powered at 24-36 V and 12-48 V must only be powered with power supplies compliant with the IEC61010 standard

## Environmental Use Conditions



- The converter can be installed internally or externally
- Altitude: untill 4000m (from -656 to 6560 feet)
- Humidity range: 0-100%

AMBIENT TEMPERATURE				
	Aluminium		Reinf. Nylon	
	Min*	Max	Min*	Max
°C	-20	+ 60	-10	+ 50
°F	-4	+140	+14	+122



**ATTENTION!** The battery will not be charged outside the below limits :

- T board MV110 < 0 °C
- T board MV110 > 50 °C

If the converter is supplied in compact version (converter over the sensor), consider the ambient temperatures more restrictive, otherwise refer to the relevant manuals.

\* For discontinuous use, a thermostat heat source installation may be necessary.

## Measurements tolerance

- Flow rate (volume) =  $\pm 0,05\%$  o.r
- Out 4/20 mA =  $\pm 0,08\%$  o.r
- Frequency Out =  $\pm 0,08\%$  o.r

## Data Plate

The instrument label contain the following information:

- ❑ MODEL: Convert Model
- ❑ S/N: Serial Number of the converter
- ❑ SUPPLY: Main power supply
- ❑ Hz: Supply frequency (AC)
- ❑ POWER: Maximum power consumption
- ❑ IP: Protection grade
- ❑ T: Operation temperature
- ❑ COUPLING: Serial number of sensor coupled
- ❑ ITEM: Free for user

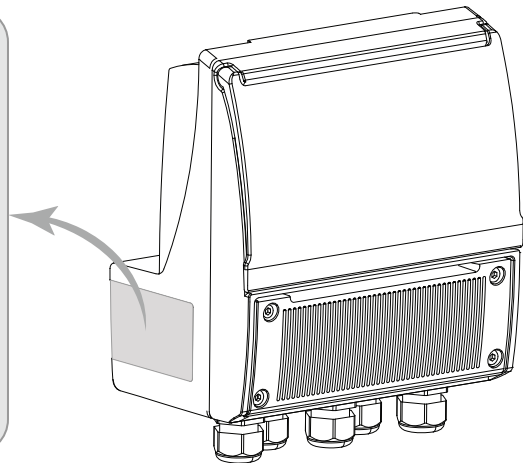

**DIMENSIONS (PLASTIC AND ALUMINIUM VERSIONS)**

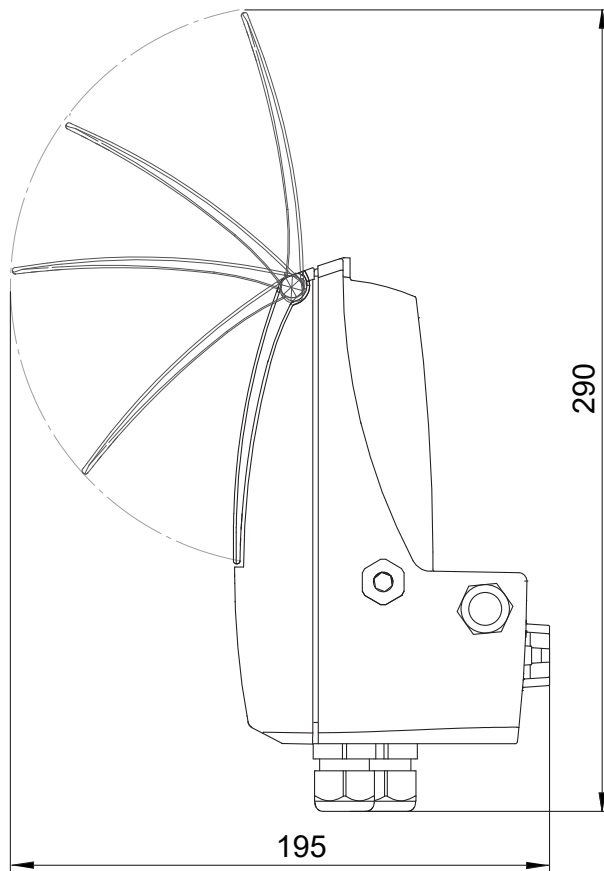
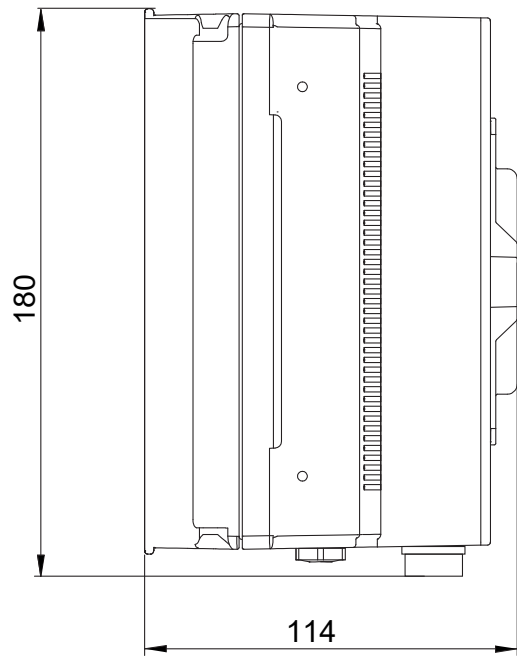
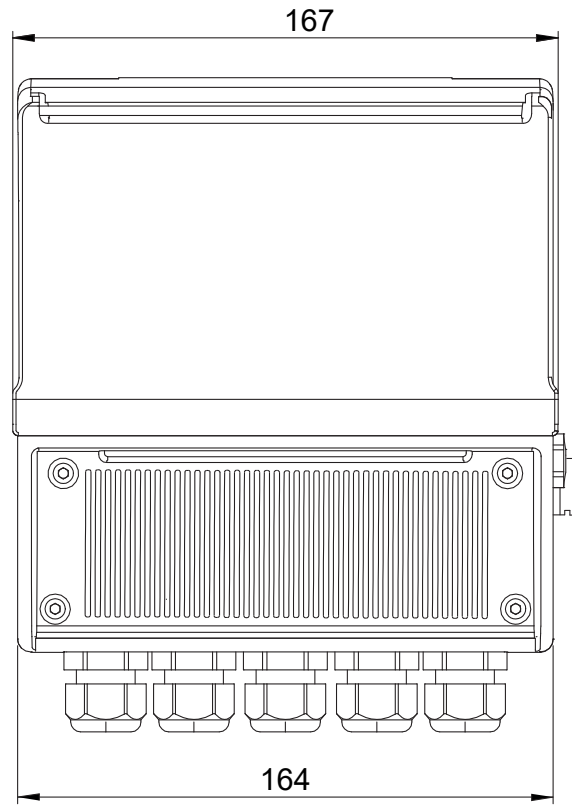
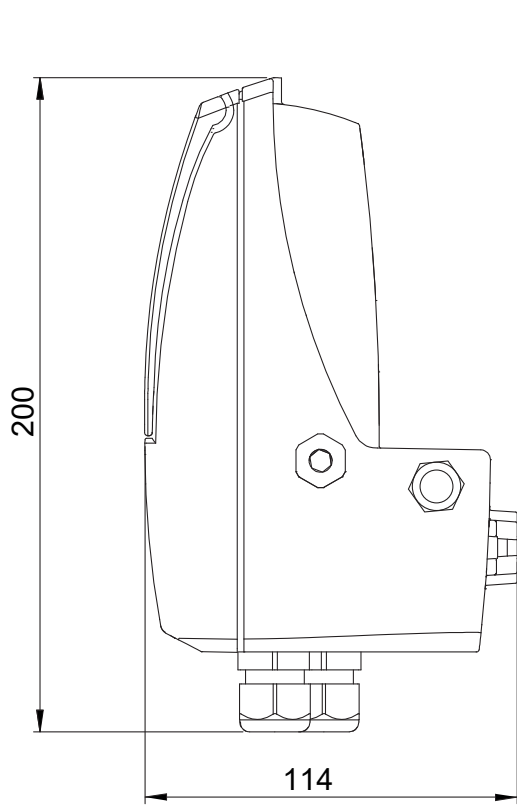

The manufacturer guarantees only English text available on our web site [www.isoil.com](http://www.isoil.com)

Separate Version

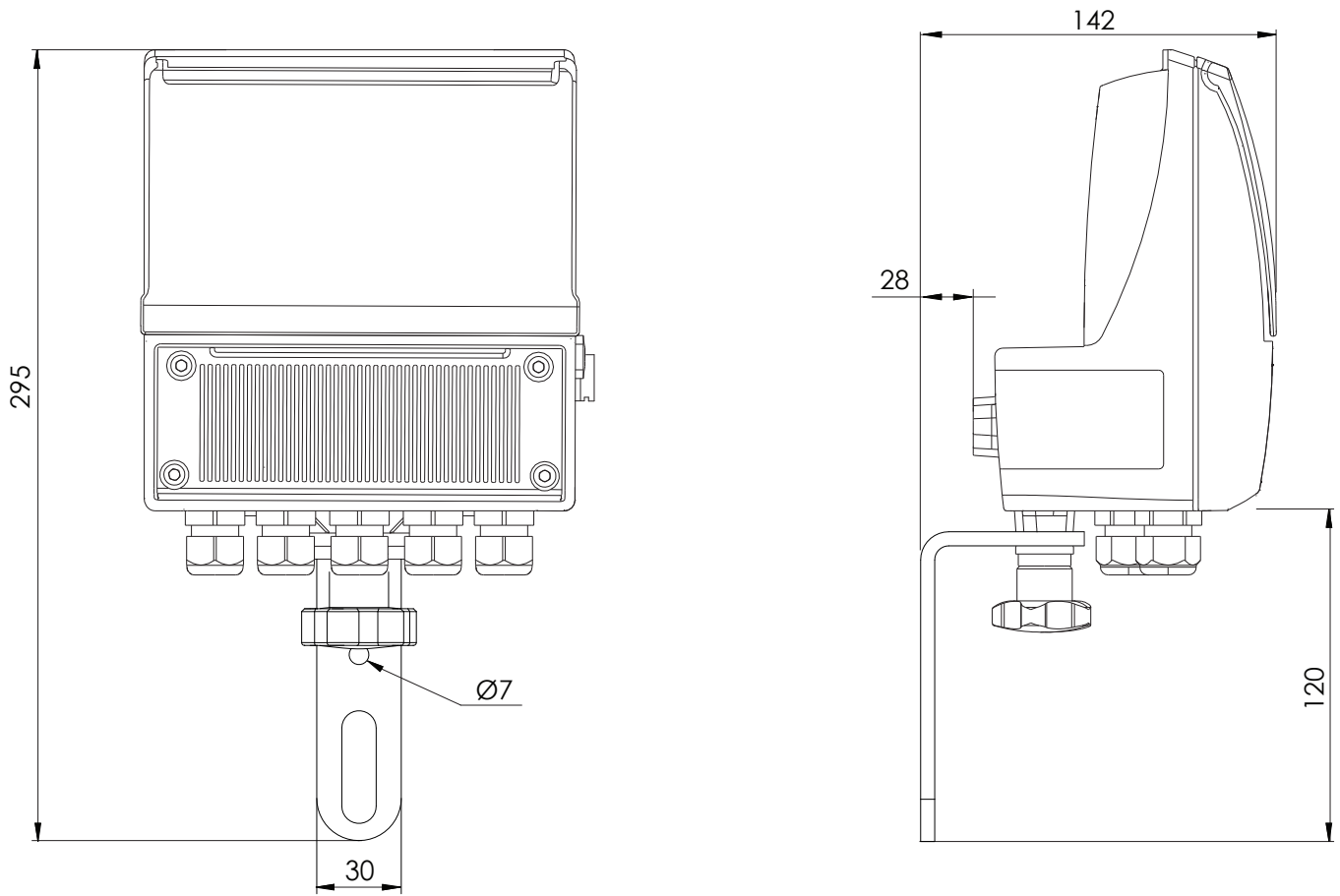

The manufacturer guarantees only English text available on our web site [www.isoil.com](http://www.isoil.com)

**Horizontal version**

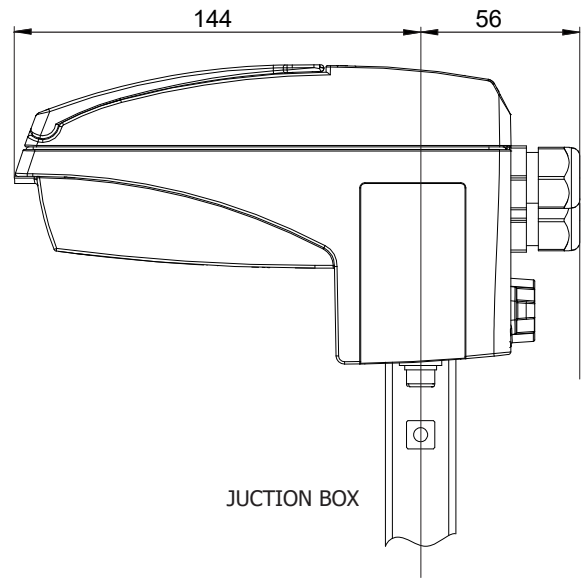
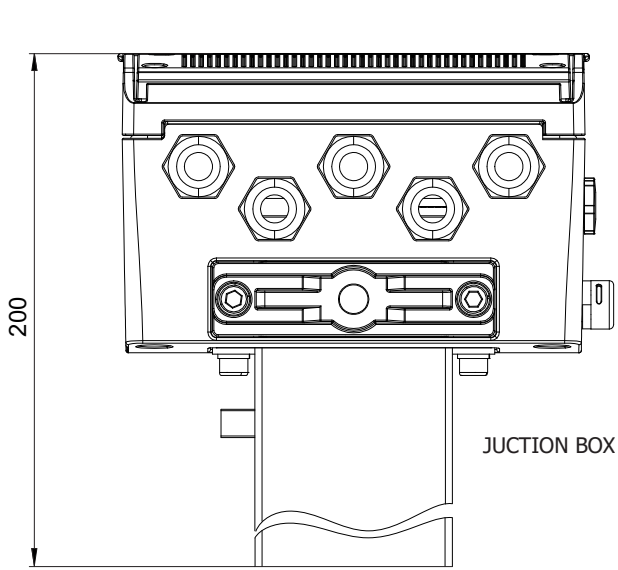

**Vertical version**

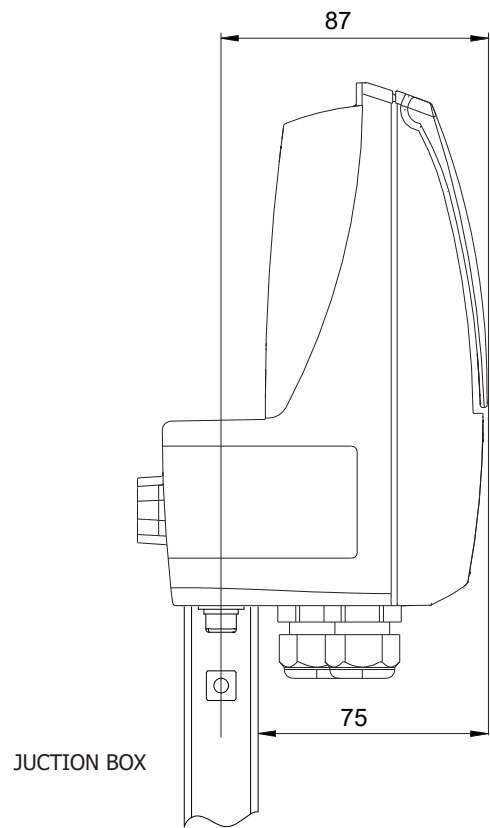
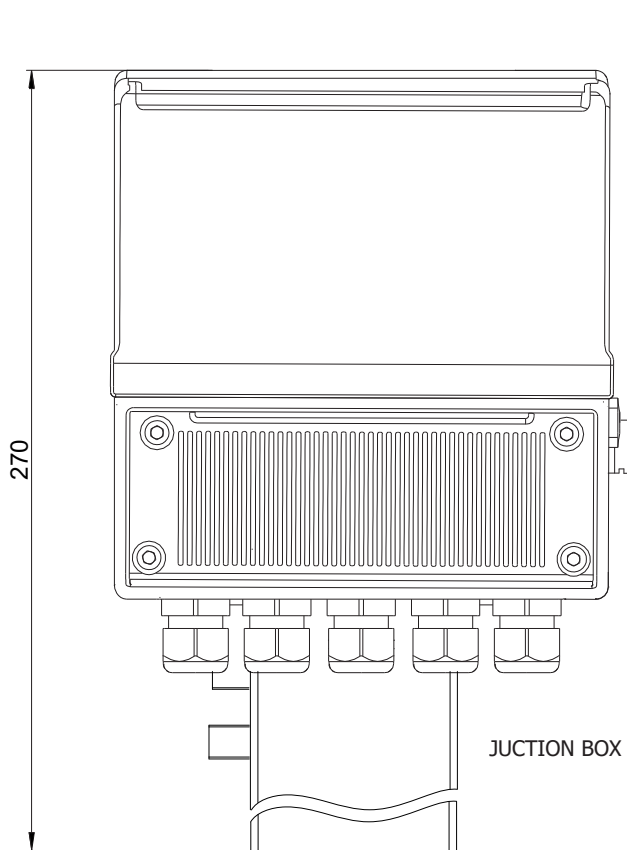

## DIMENSIONS (STAINLESS STEEL VERSION)

### Compact Version

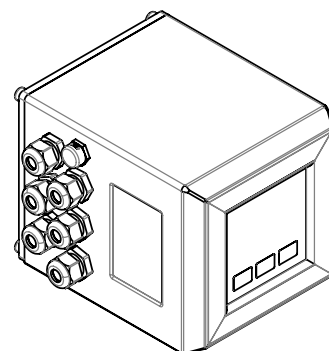
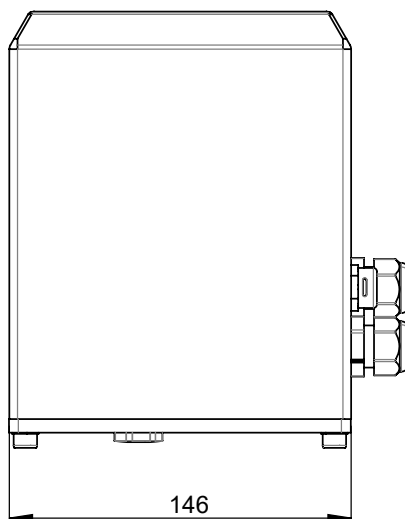
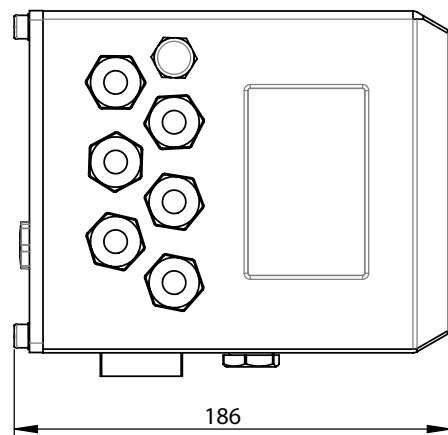
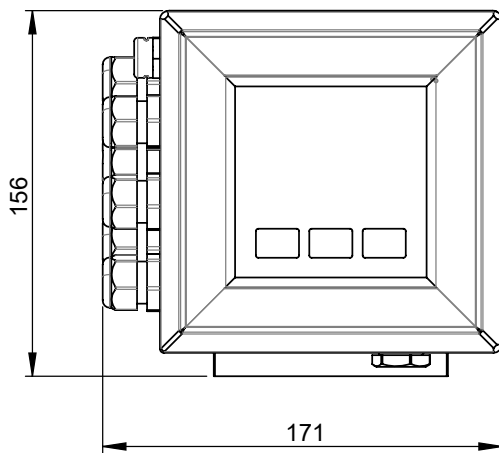

The manufacturer guarantees only English text available on our web site [www.isoil.com](http://www.isoil.com)

Separate Version

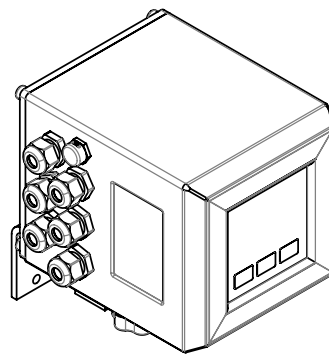
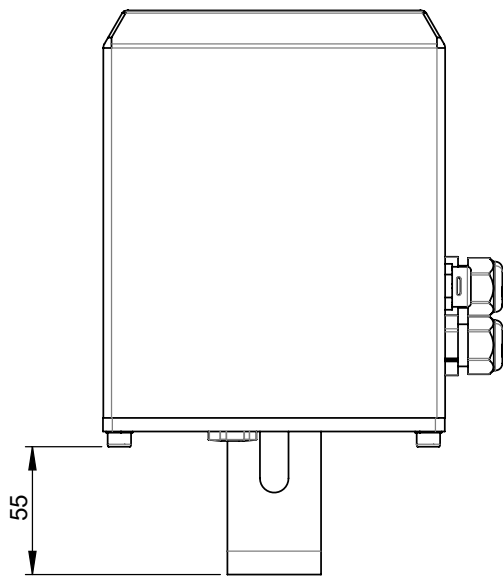
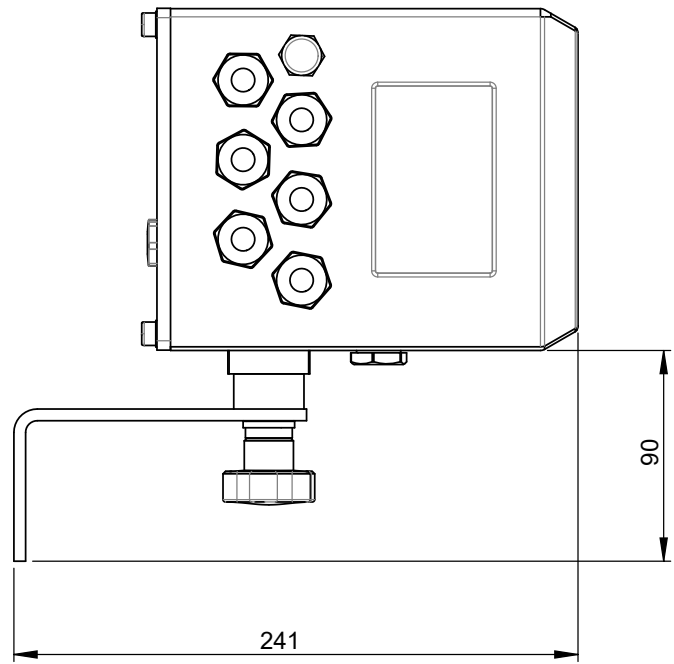
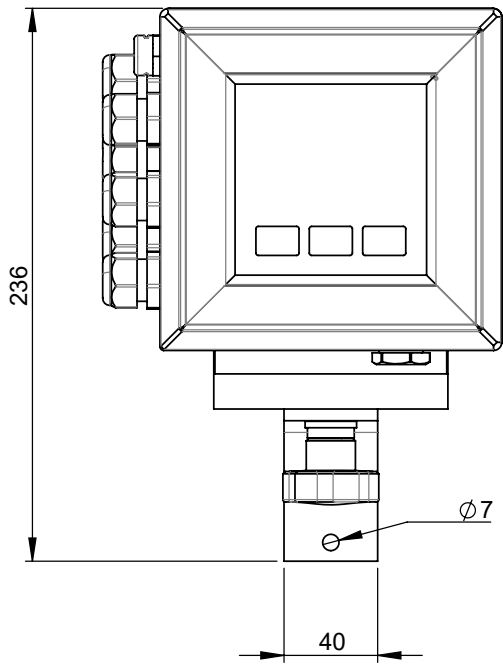

The manufacturer guarantees only English text available on our web site [www.isomag.com](http://www.isomag.com)

# TORQUES

To guarantee the housing's IP degree the following torques are required:

## Aluminium and PA6 version

HOUSING MATERIAL	Housing screws (1)	Screws Terminal block cover (2)	Fixing Display Frame	PCB Screws	Version Cap (3)	Cable Glands (4)	Cap USB-B (5)
ALUMINIUM HOUSING	6 Nm	5.5 Nm	3 Nm	0.8 Nm	8 Nm	4 Nm	4 Nm
PLASTIC HOUSING	2 Nm	2 Nm	2.5 Nm	0.8 Nm	7 Nm	4 Nm	4 Nm

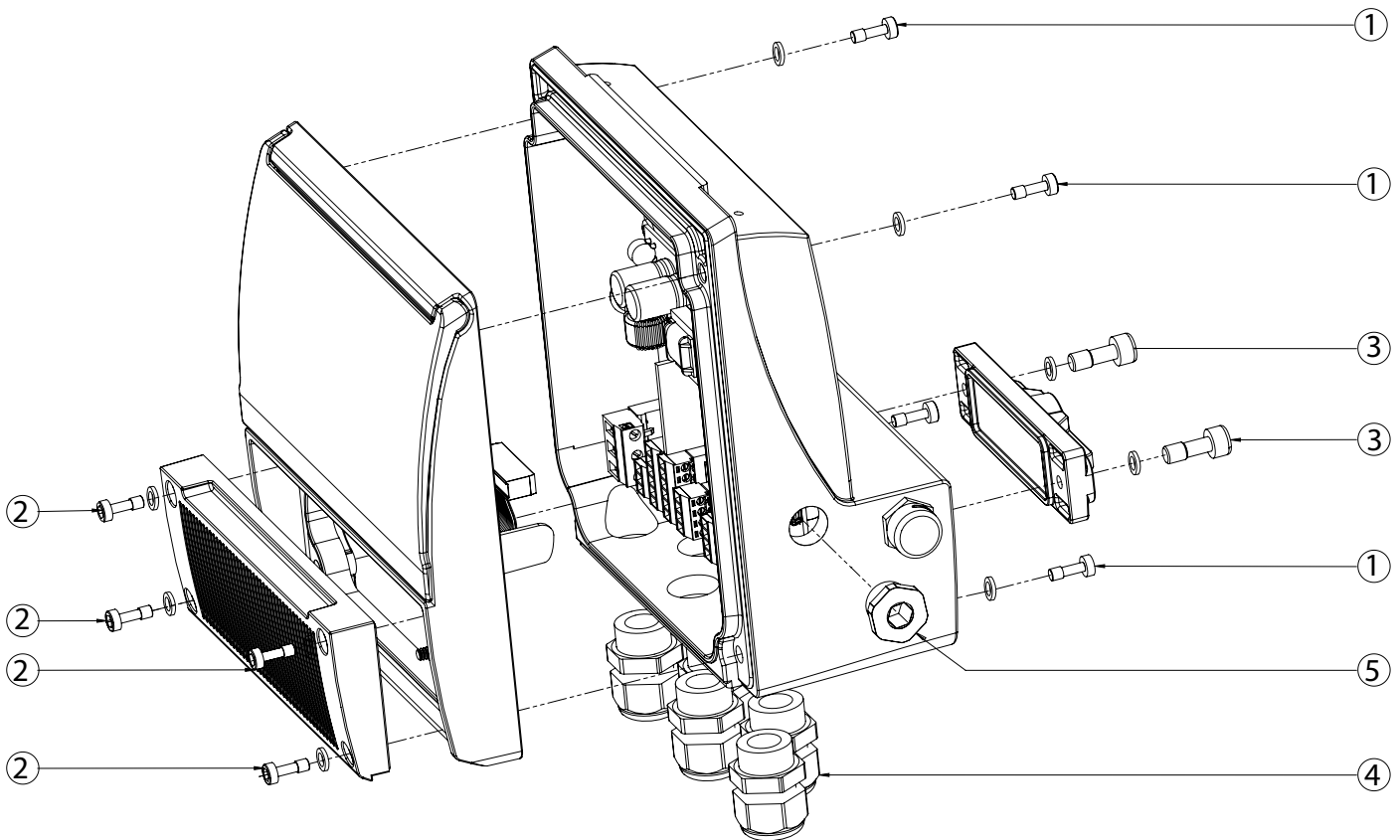

The manufacturer guarantees only English text available on our web site www.isoil.com

## Stainless steel housing

HOUSING MATERIAL	Housing screws (1)	PCB Screws (2)	Cable Glands (3)	Cap USB-B (4)
Stainless steel HOUSING	2.5 Nm	0.8 Nm	4 Nm	hand-tighten

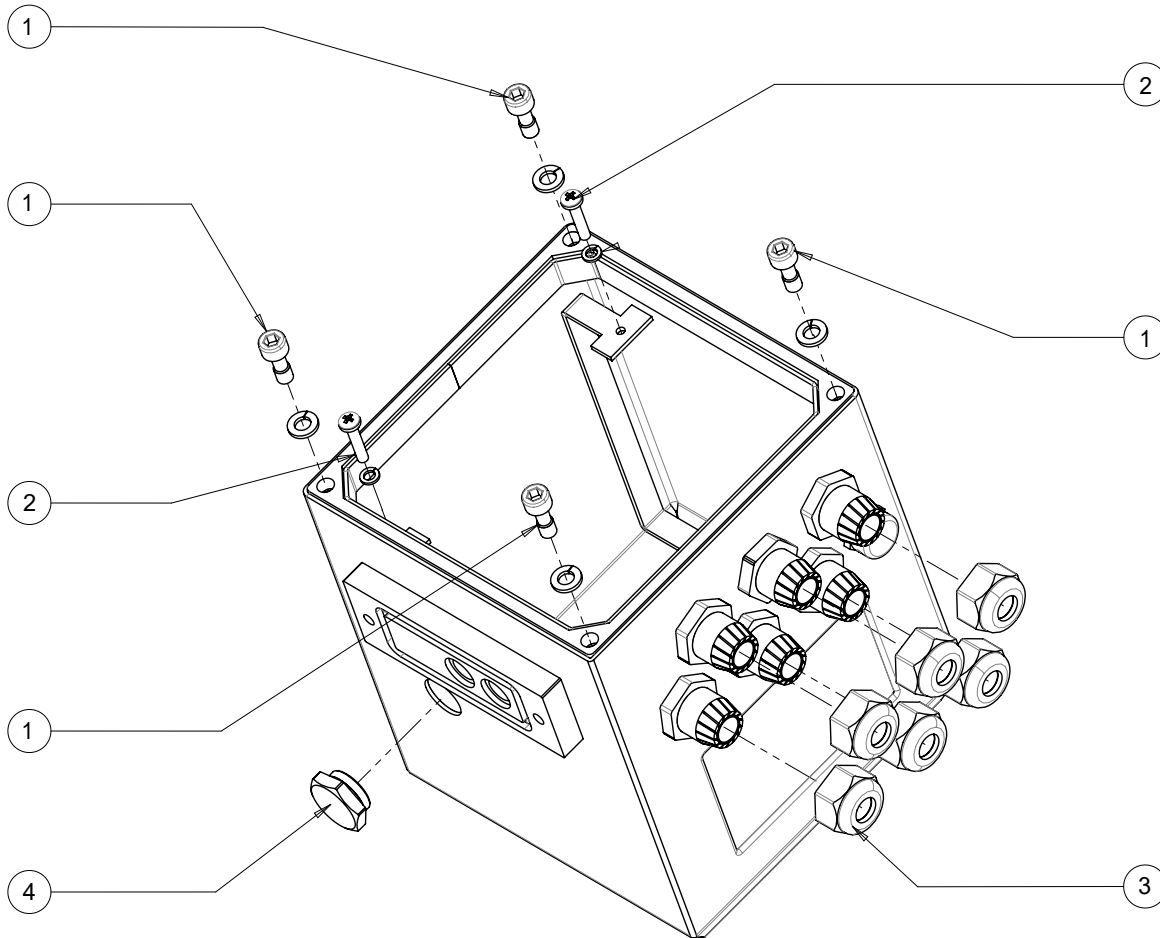

The manufacturer guarantees only English text available on our web site [www.isomag.com](http://www.isomag.com)

# MV110 CONSTRUCTION (ALUMINIUM AND PA6 VERSIONS)

## TERMINAL BLOCK COVER

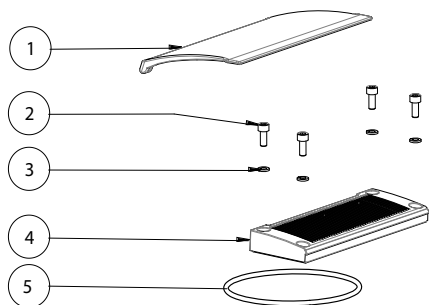

## MAIN HOUSING COVER

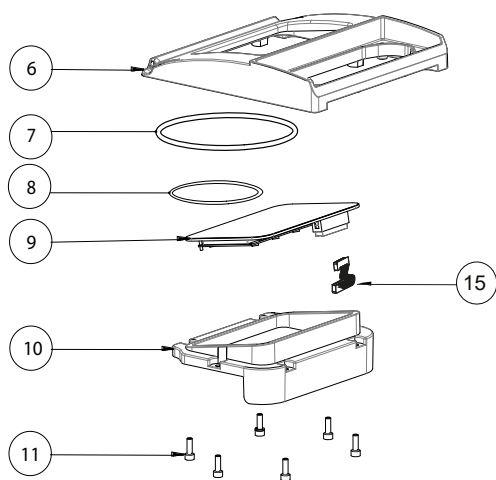

## PCB MV110

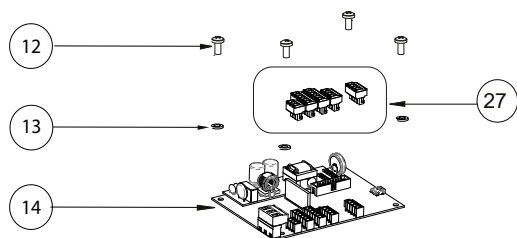

## MAIN HOUSING

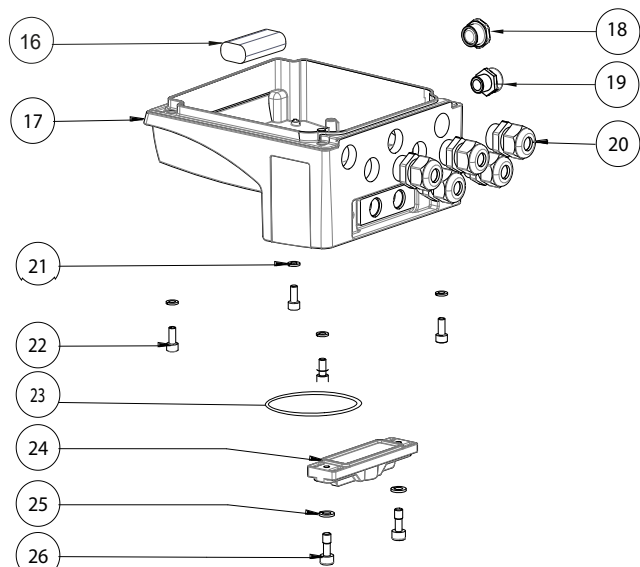

POS.	DESCRIPTION	
	PA6 VERSION	ALLUMINIUM VERSION
1	PROTECTION COVER	
2	VITE M4x12	VITE M5x12
3	GROWER Ø4	GROWER Ø5
4	TERMINAL COVER	TERMINAL COVER
5	O-RING-4400	
6	HOUSING COVER	HOUSING COVER
7	O-RING-4700 (HOUSING COVER)	
8	O-RING-117x3 (DISPLAY)	
9	DISPLAY	
10	FIXING DISPLAY FRAME (MATERIAL PA06)	
11	SELF-TAPPING SCREW 4x10	TRILOBO SCREW 4x10
12	SELF-TAPPING SCREW 4x10	TRILOBO SCREW 4x10
13	GROWER Ø4	SPRING WASHER Ø4
14	PCB MV110	
15	FLAT CABLE	
16	LITHIUM BATTERY	
17	PA6 MAIN HOUSING	ALUMINIUM MAIN HOUSING
18	PG9 CAP	
19	PRESSURE COMPENSATION PLUG	
20	PG11 CABLE GLAND CABLE DIAMETER: Ø5-Ø10mm	
21	GROWER Ø4	SPRING WASHER Ø5
22	SCREW M4x12	SCREW M5x12
23	O-RING-155	
24	VERSION CAP (MATERIAL PA06)	
25	GROWER Ø6	
26	SCREW M6x16	
27	TERMINAL BLOCK SOLID WIRE: 26-16 AWG / 0.129-1.31 mm <sup>2</sup> STRANDED WIRE: 26-16 AWG / 0.129-1.31 mm <sup>2</sup> TORQUE: 3.0 Lb.In / 0.34 Nm	

The manufacturer guarantees only English text available on our web site www.isoil.com

## MV110 CONSTRUCTION (STAINLESS STEEL VERSION)

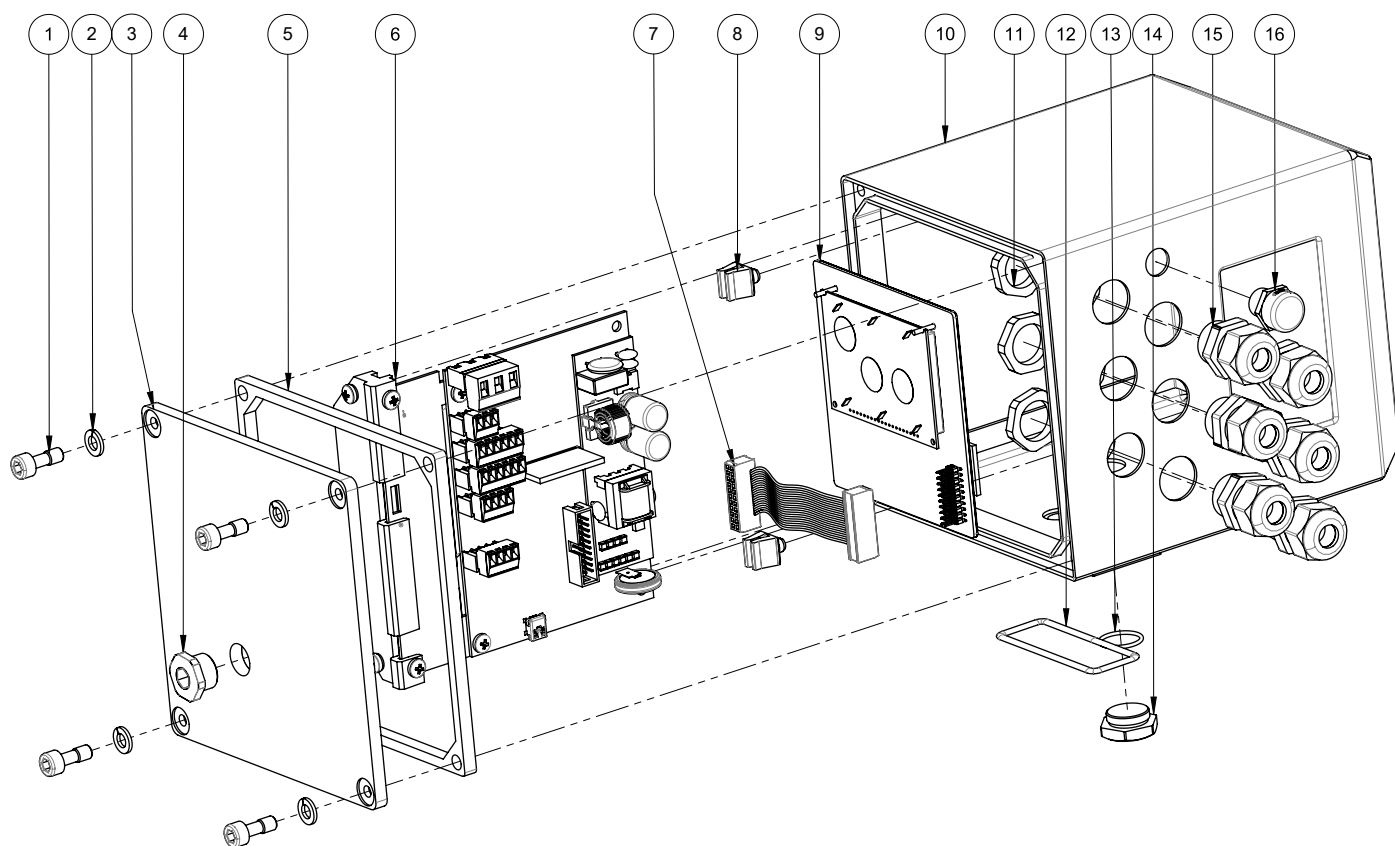

POS.	DESCRIPTION
1	SCREW M6X16
2	GROWER Ø 6
3	POLISHED COVER
4	PG9 CAP IP68
5	GASKET FOR Stainless steel HOUSING
6	BOARD FRAME M3C
7	FLAT CABLE
8	BOARD FIXING CLIPS
9	DISPLAY/BLIND
10	POLISHED Stainless steel HOUSING
11	PG11 NUT
12	FLAT GASKET O-RING 155
13	O-RING ORM 0160-15 Ø16X1.5
14	Stainless steel CAP M18X0.75
15	PG11 CABLE GLANDS
16	ANTICONDENSATION CAP

# INTERNAL LAYOUT

## Internal Converter Views

Remove the main housing cover by removing the 4 screws as shown here below.

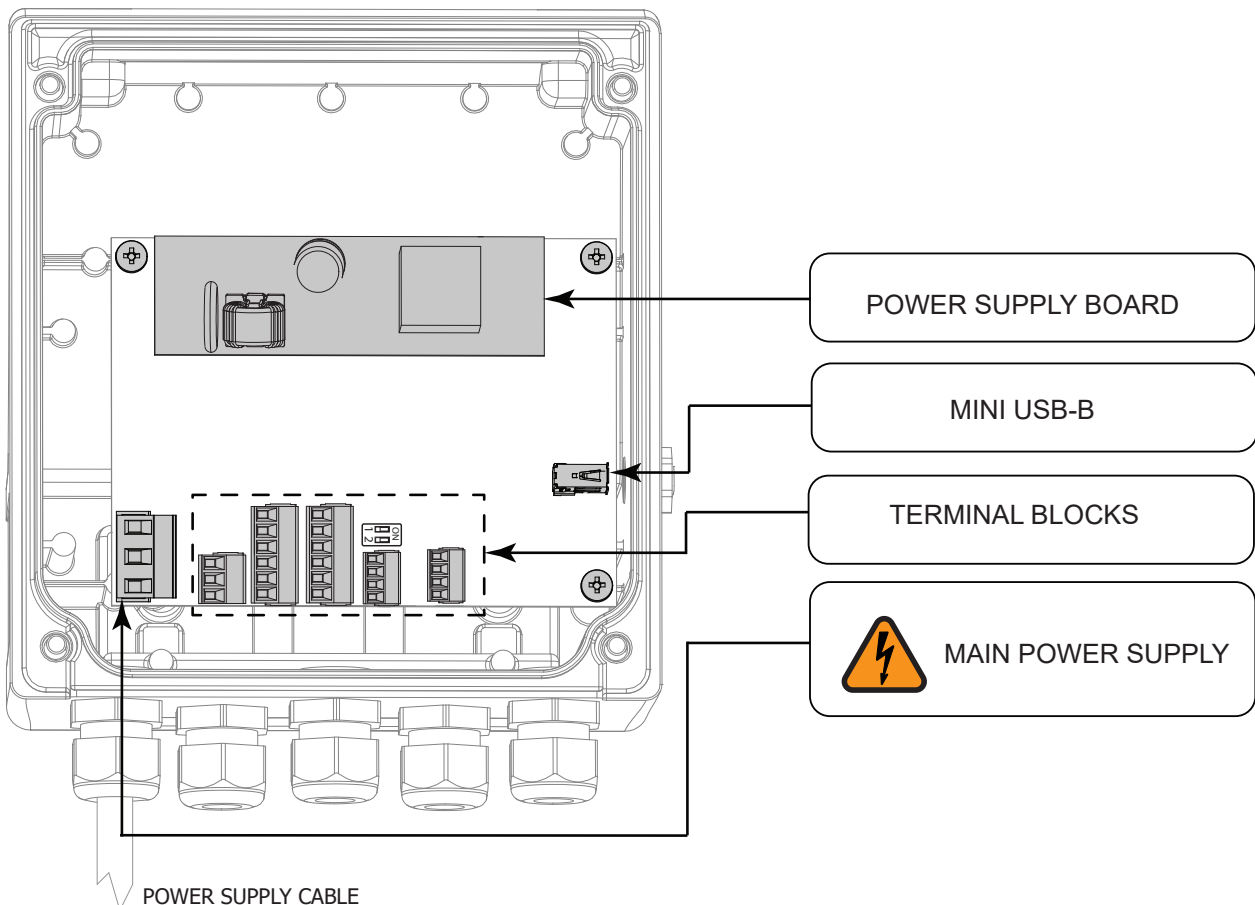
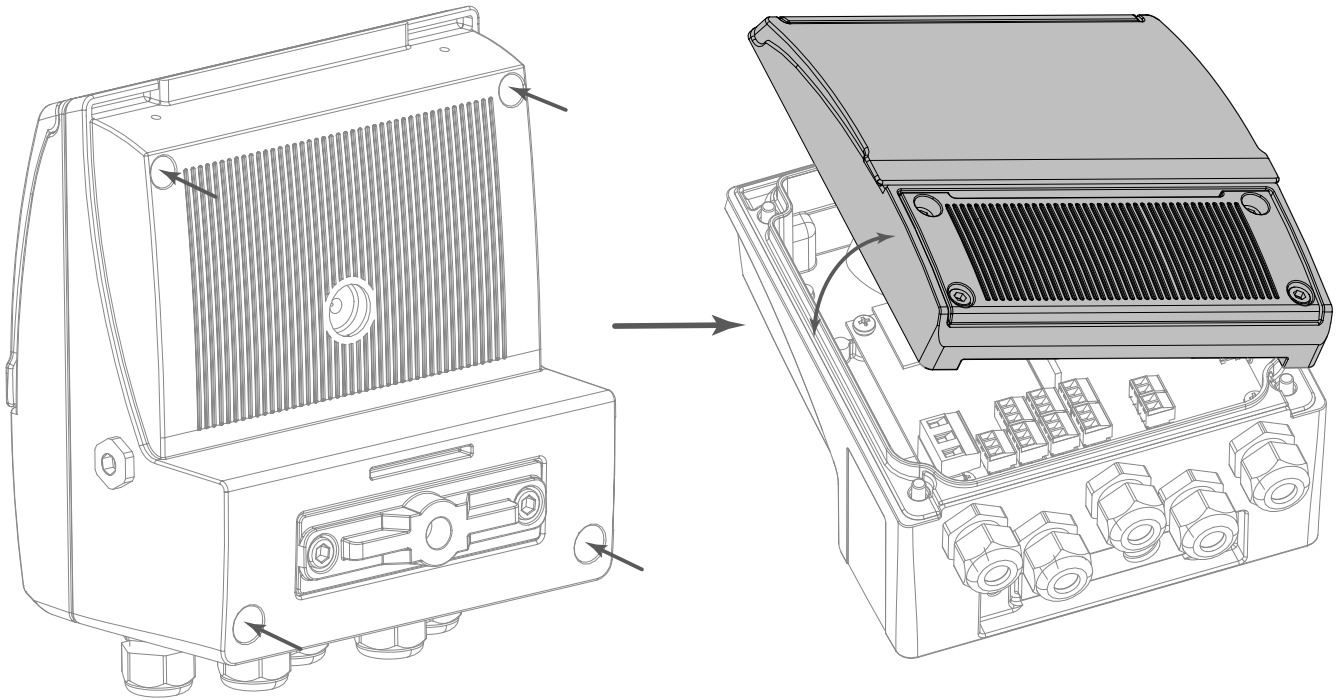

The manufacturer guarantees only English text available on our web site www.isoil.com

## ELECTRICAL CONNECTION AND GROUNDING INSTRUCTIONS



Always ensure that the converter and the sensor are grounded (earthed) correctly. The grounding of the sensor and converter **must** ensure that the instrument and liquid are equipotential.

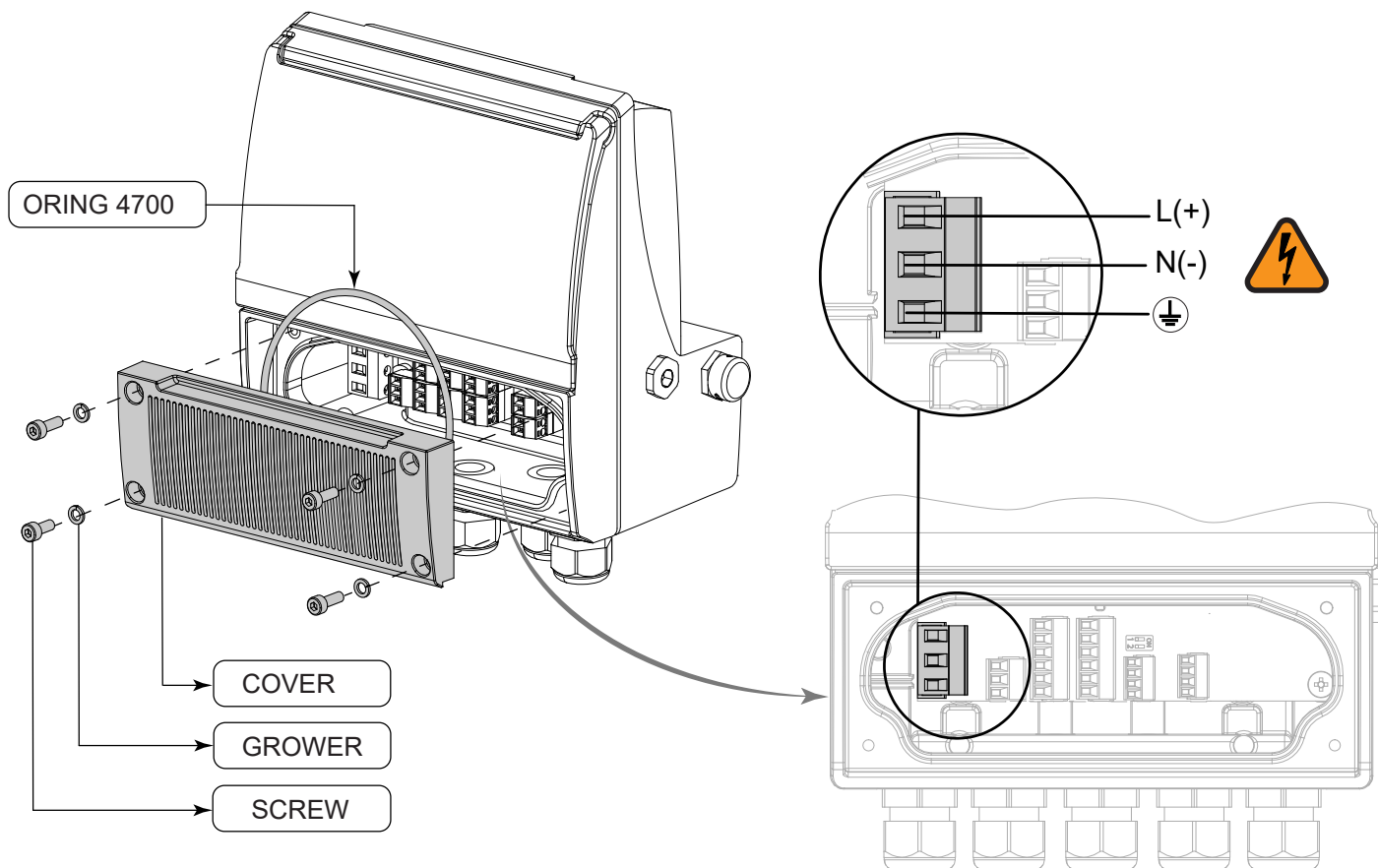

- ❑ Before connecting the power supply, verify that the mains voltage is within the limits indicated on data plate.
- ❑ For the connections use only approved conductors, with fire-proof properties, whose section varies from 0.25 mm<sup>2</sup> to 1.50 mm<sup>2</sup>, based on distance/power; additionally fix the power supply wires with a additional fastening system located close to the terminal.
- ❑ The power supply line must be equipped with an external protection for overload current (fuse or automatic line breaker).
- ❑ Provide in close proximity the converter a magnetotermic circuit breaker easily accessible for the operator and clearly identified; whose symbols must conform to the electrical safety and local electrical requirements.
- ❑ Ensure that the component complies with the requirements of the standard for electrical safety distance.
- ❑ Check chemical compatibility of materials used in the connection security systems in order to minimize electrochemical corrosion. In the aluminum housing it should avoid direct contact between the ground connection cable and the aluminum housing. It is therefore recommended to connect the safety ground cable, by placing it between the washer and the metal bracket on the related terminal or use an eyelet terminal crimped on the ground protection cable.
- ❑ The sensor, hardwired inputs and outputs are connected to the converter through terminal blocks located inside the converter.
- ❑ To locate the terminal block loosen the 4 screws on the terminal block cover. When the front cover is lifted, the terminal block is visible. The terminal block is the hardwire connection of the converter to external equipment, including the sensor.
- ❑ The mains power cables must have adequate values for the maximum current of the appliance, and the cable used must house the standards of the IEC 60227 standard or the IEC 60245 standard.

The following pages give informations on the terminal block numbering, and the respective connecting of the sensor cables, and inputs/outputs.

# INTERNAL LITHIUM BATTERY

## Aluminium and PA6 version

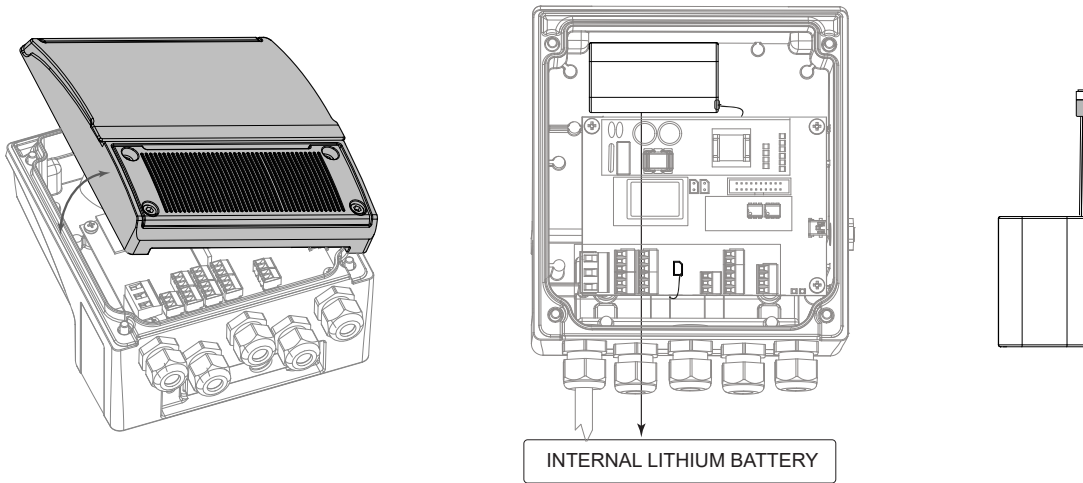

## Stainless steel version

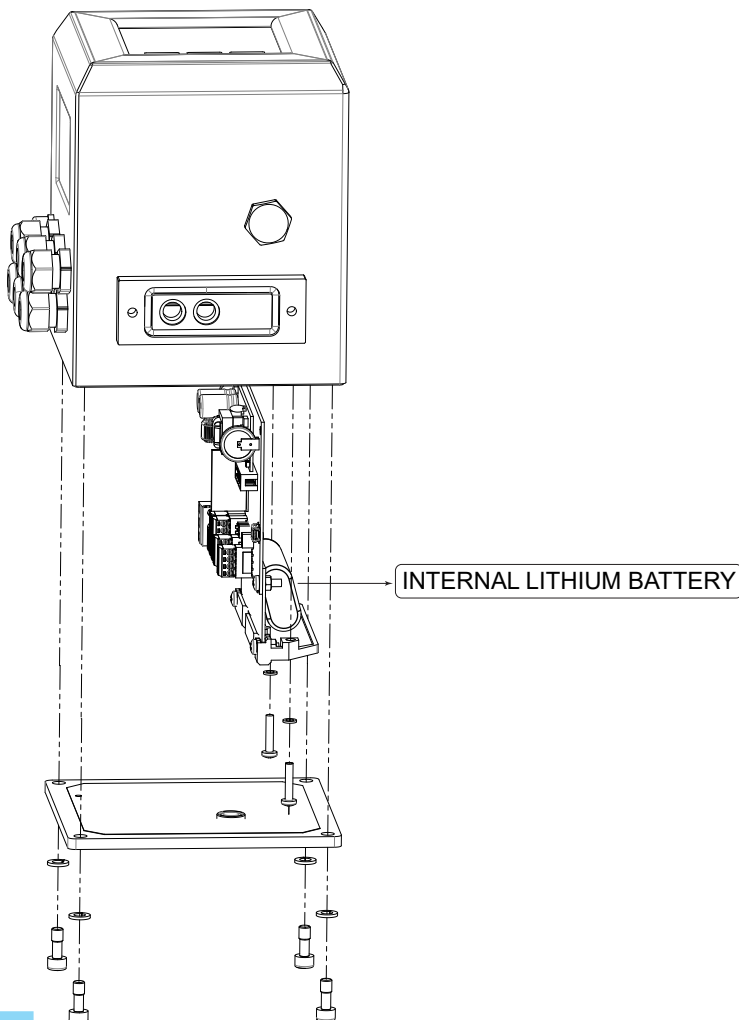

The manufacturer guarantees only English text available on our web site [www.isoil.com](http://www.isoil.com)

## ATTENTION

- ❑ The internal lithium battery is rechargeable and should never be disconnected from the converter card when it is powered by the mains voltage. If this operation should be carried out it could irreparably damage the converter board.
- ❑ The internal lithium battery is recharged only when the converter is connected to the mains supply (LV, LLV, HV), battery charging condition, and not with the USB connection.
- ❑ During charging, the battery symbol appears on the MCP display and flashes blue; see "MEANING OF FLAGS" page 27 (the colors of the symbols can only be viewed in the virtual display of the MCP interface)
- ❑ When the battery charge falls below the minimum potential, battery low, the fixed red battery symbol appears; see "MEANING OF FLAGS" page 27 (the symbol colors can only be displayed in the virtual display of the MCP interface). Furthermore, in this charging condition below the minimum potential, the measurement does not start when the USB cable is connected.
- ❑ The thresholds that identify the condition of Battery low and battery charging are established by the system according to the use and settings assigned and therefore there is no fixed value..
- ❑ The two Battery low and battery charging icons can both be present as each one indicates a different condition.

## GENERAL OPERATING NOTES

- ❑ If the mains voltage is disconnected from the converter with HV power supply, the flashing blue icon indicating the charging status can remain active for tens of seconds. This is due to the energy stored in the HV power supply and in the capacities of the circuit that discharge slowly.
- ❑ The battery voltage during charging does not rise immediately but gradually. This is related to the parameters set in the converter and detected by the controller chip.
- ❑ When the battery is physically disconnected the potential measured by the system is not true because the charging circuit checks the battery status by emitting impulses. These load the capacities in the circuit and the average value detected is not to be considered a reliable real value.
- ❑ The MCP command [SBCHS] indicates the percentage of charge and is not linear with respect to the battery voltage, however approximately it reads 0% with a voltage equal to about 3.2 V, while 100% occurs with about 4.1 V. These values are influenced by the temperature and the total operating time that worked the battery.

# ELECTRICAL CONNECTION CONVERTER- SENSOR



Sudden movements of the electrodes cable could introduce noise.

SH = SHIELD OF CABLE internally connected to ground.

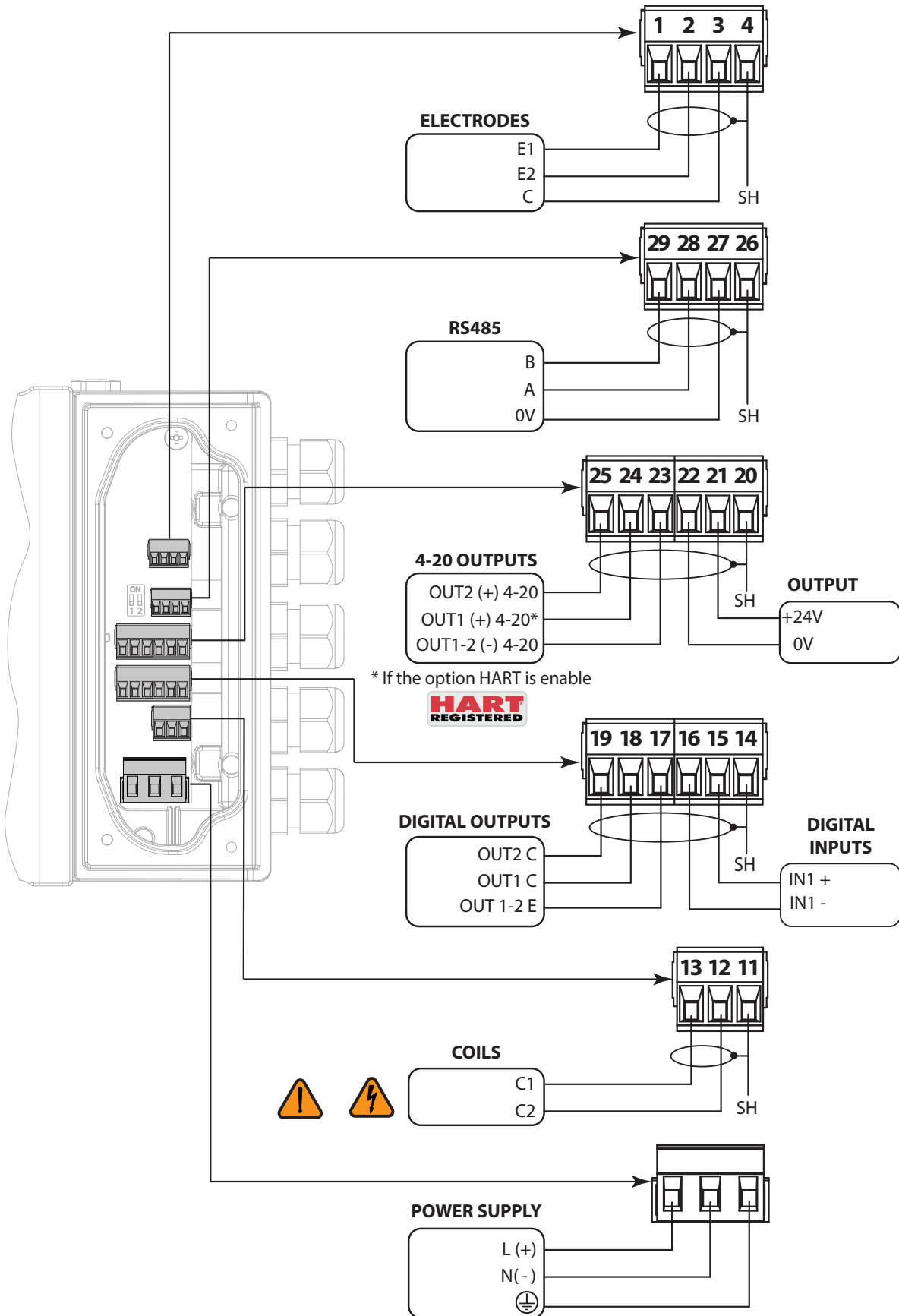

The manufacturer guarantees only English text available on our web site www.isoil.com

# DIGITAL INPUT ON/OFF OPERATION

## EXTERNAL POWER SUPPLY

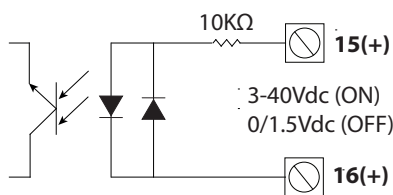

## INTERNAL POWER SUPPLY

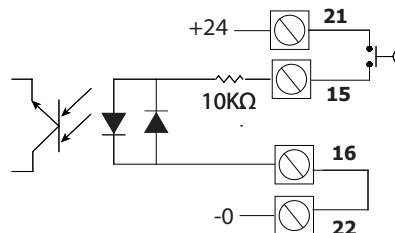

## RESET TOTALIZERS

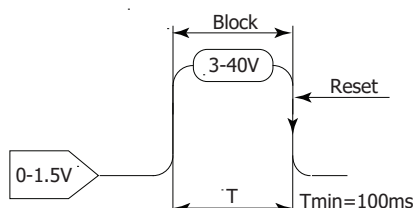

### Necessary conditions for enabling the function

- POS. 6.1 see page 35 (T+; total direct positive set on)
- POS. 6.2 see page 35 (P+; partial direct positive set on)
- POS. 6.3 see page 35 (T-; total direct negative set on)
- POS. 6.4 see page 35 (P-; total direct negative set on)

## BLOCK TOTALIZERS

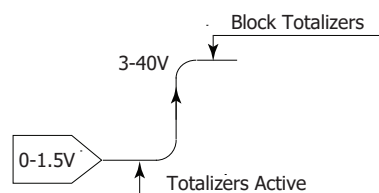

### Necessary conditions for enabling the function

- POS. 6.5 see page 35 (Totalizer counting lock command set on)

## RANGE CHANGE

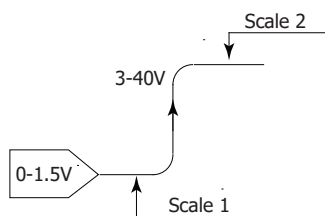

### Necessary conditions for enabling the function

- POS. 6.8 see page 35 (Range change set on)

## MEASURE LOCK

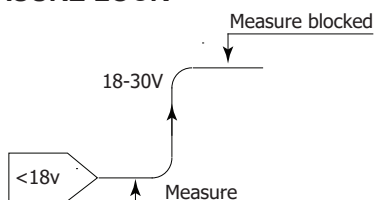

### Necessary conditions for enabling the function

- POS. 6.6 see page 35 (Totalizer counting lock command set on)



SAMPLE RATE	Tmin
10HZ	220ms
20HZ	110ms
50HZ	45ms

MUST BE  
T > Tmin

## OUTPUTS WIRING

### digital outputs

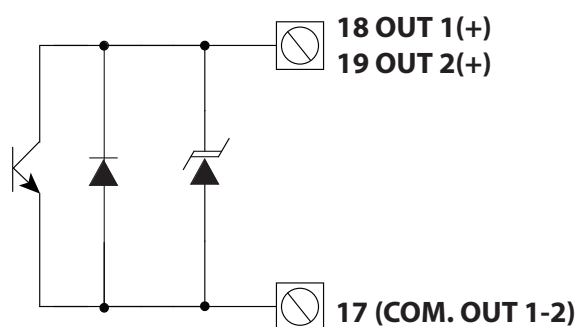

- Opto-insulated output with floating collector and emitter terminals freely connectable
- Maximum switching voltage: 30V ---
- Maximum switching current: 100mA @ 25°C
- Maximum saturation voltage between collector and emitter @100mA: 1.2V
- Maximum switching frequency (load on the collector or emitter,  $R_L=470$ ,  $V_{OUT}=24V$  --- ): 1250Hz
- Maximum reverse current bearable on the input during and accidental polarity reversion (VEC): 100mA
- Insulation from other secondary circuits 500 V ---

### analog outputs

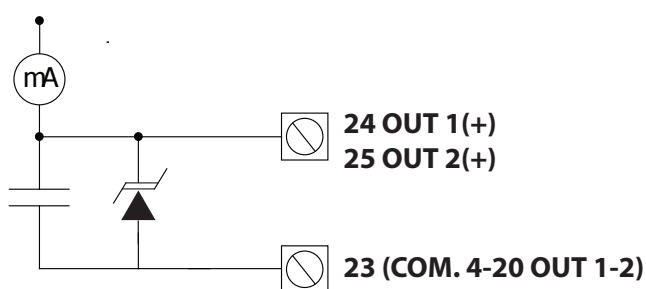

- Opto-insulated output
- Maximum load: 1000Ω
- Maximum voltage without load: 27V ---
- Refresh frequency is the same of the sample frequency of the connected sensor
- Protected against persistent over voltages to maximum 30V ---

## RS485 MODBUS MODULE (OPTIONAL)

Positioning to 'ON' the termination switches 1 and 2, a 120Ω résistance is activated in the RS485 circuit (see terminal block).

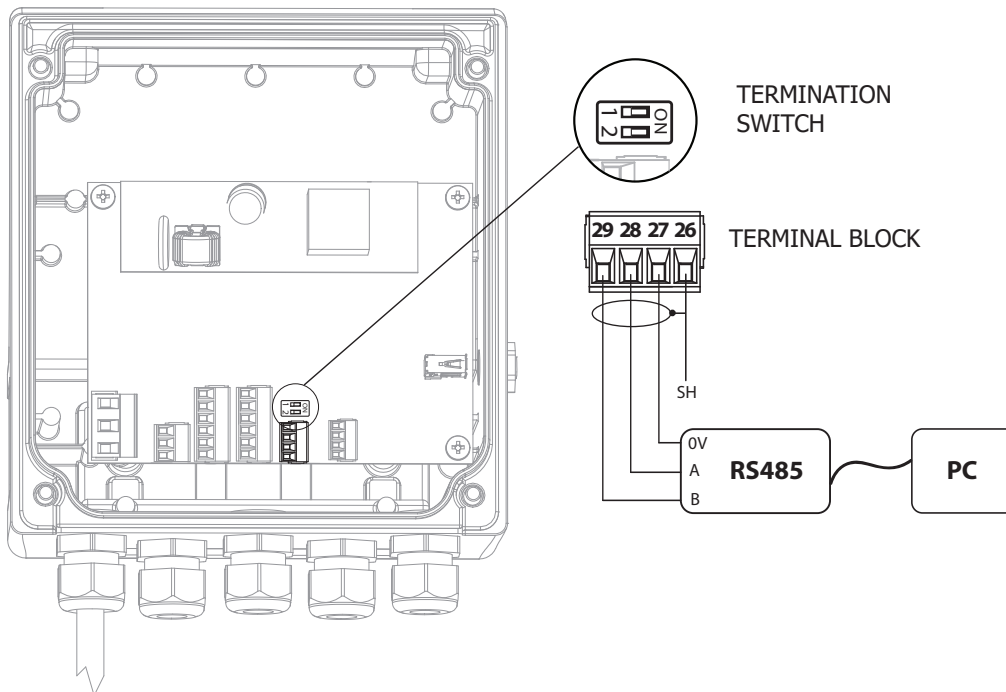

The manufacturer guarantees only English text available on our web site [www.isoil.com](http://www.isoil.com)

## CONNECTORS MIL

THE following are the links of the MIL connectors IP68

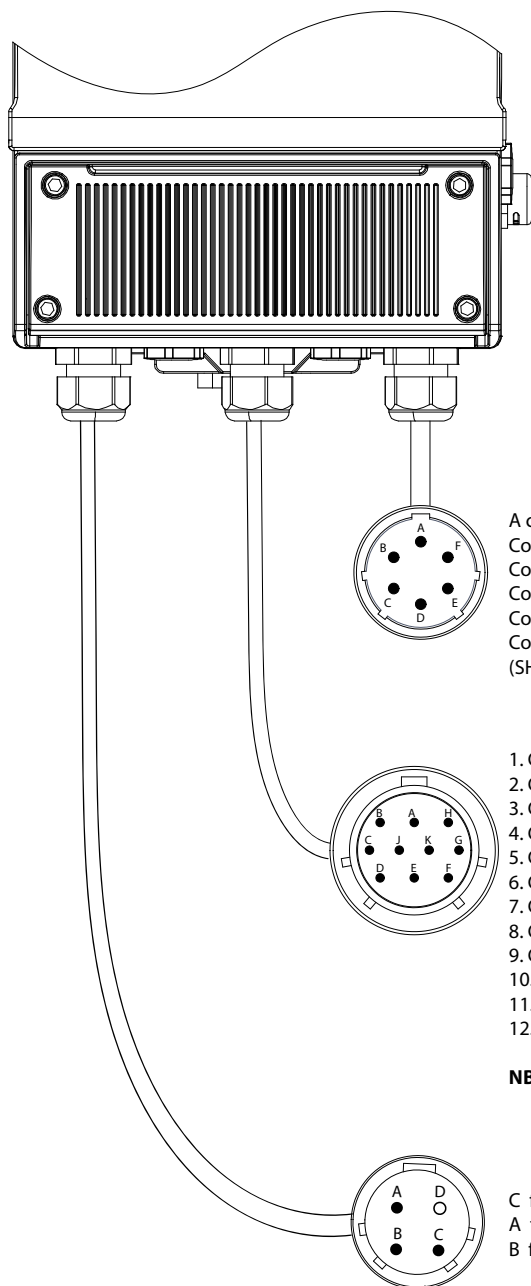

### SENSOR SIGNALS

- A contact from terminal 1 of the converter (electrode 1)
- Contact F from terminal 2 of the converter (electrode 2)
- Contact from terminal 3 of the converter (COM. Elec.)
- Contact B from terminal 13 of the converter (COIL 1)
- Contact C from terminal 12 of the converter (COIL 2)
- Contact D from terminal 4 and 11 of converter (SHIELD electrodes - COILS)

Connector  
6 poles

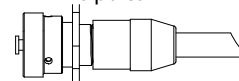

### INPUT/OUTPUT

1. Contact B from terminal 24 of the converter (Out1 4-20 +)
2. Contact A from terminal 25 of the converter (Out2 4-20 +)
3. Contact H from terminal 23 of the converter (Out1-2 4-20 -)
4. Contact C from terminal 21 of the converter (+ 24V)
5. Contact J from terminal 22 of the converter (0V)
6. Contact K from terminal 15 of the inverter (IN1 +)
7. Contact G from terminal 16 of the converter (IN1-)
8. Contact D from terminal 19 of the converter (C Out2)
9. Contact E from terminal 18 of the converter (Out1 C)
10. Contact F from terminal 17 of the converter (Out1-2 E)
11. Contact C from terminal 28 of the converter (RS485 A)
12. Contact J from terminal 29 of the converter (RS485 B)

Connector  
10 poles

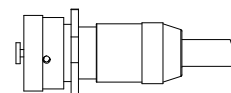

**NB:** the connections 4 and 5 exclude the use connections 11 and 12.

### POWER SUPPLY

- C from terminal L power converter (+ dc)
- A from terminal N power converter (-dc)
- B from terminal GROUND Power Converter

Connector  
4 poles



**NOTE:** Military Connector 6 poles for sensor converter only provided in the separate version of the converter.

The manufacturer guarantees only English text available on our web site www.isoil.com

## START VISUALIZATION PAGES



The direct exposure of the converter to the solar rays, could damage the liquid crystal display. The visualization pages can be change according to instrument's setup.



Push to change visualization

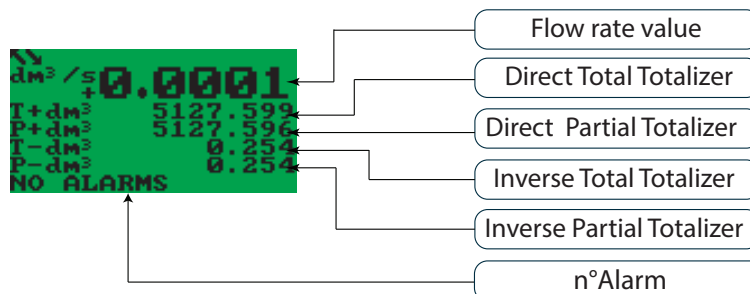
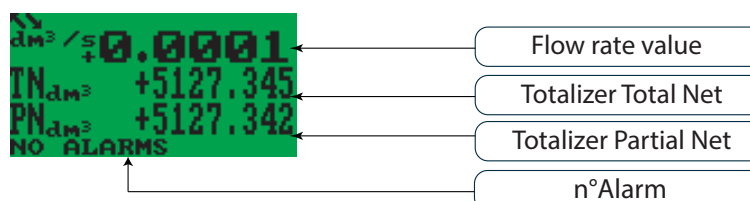
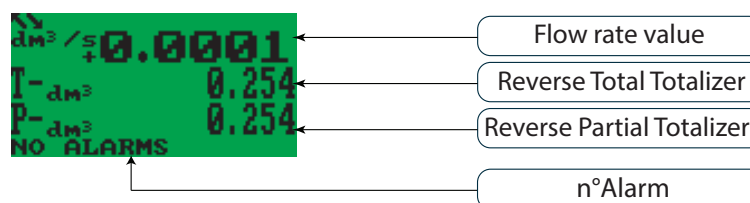
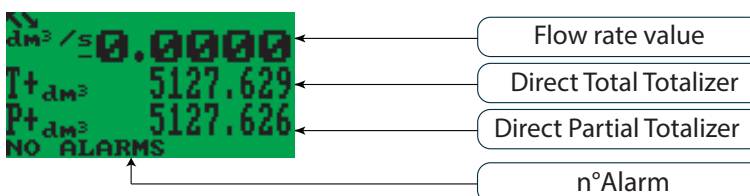
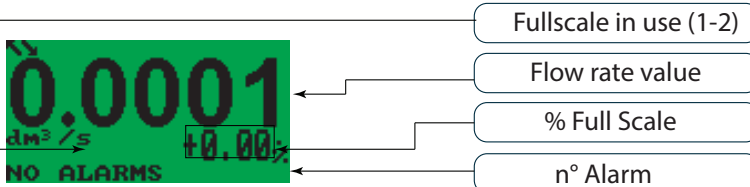
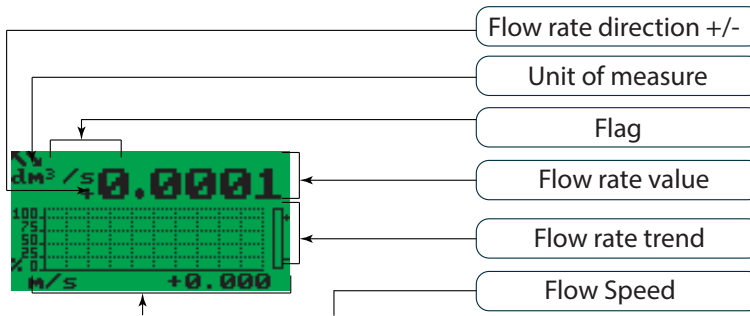
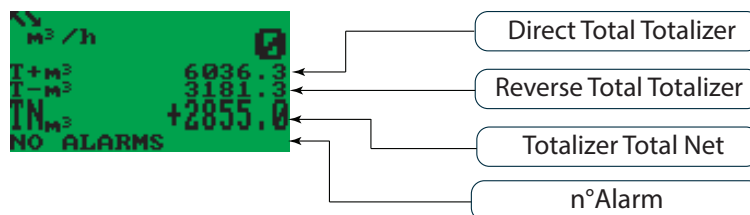

The manufacturer guarantees only English text available on our web site www.isoil.com

 Push to change visualization

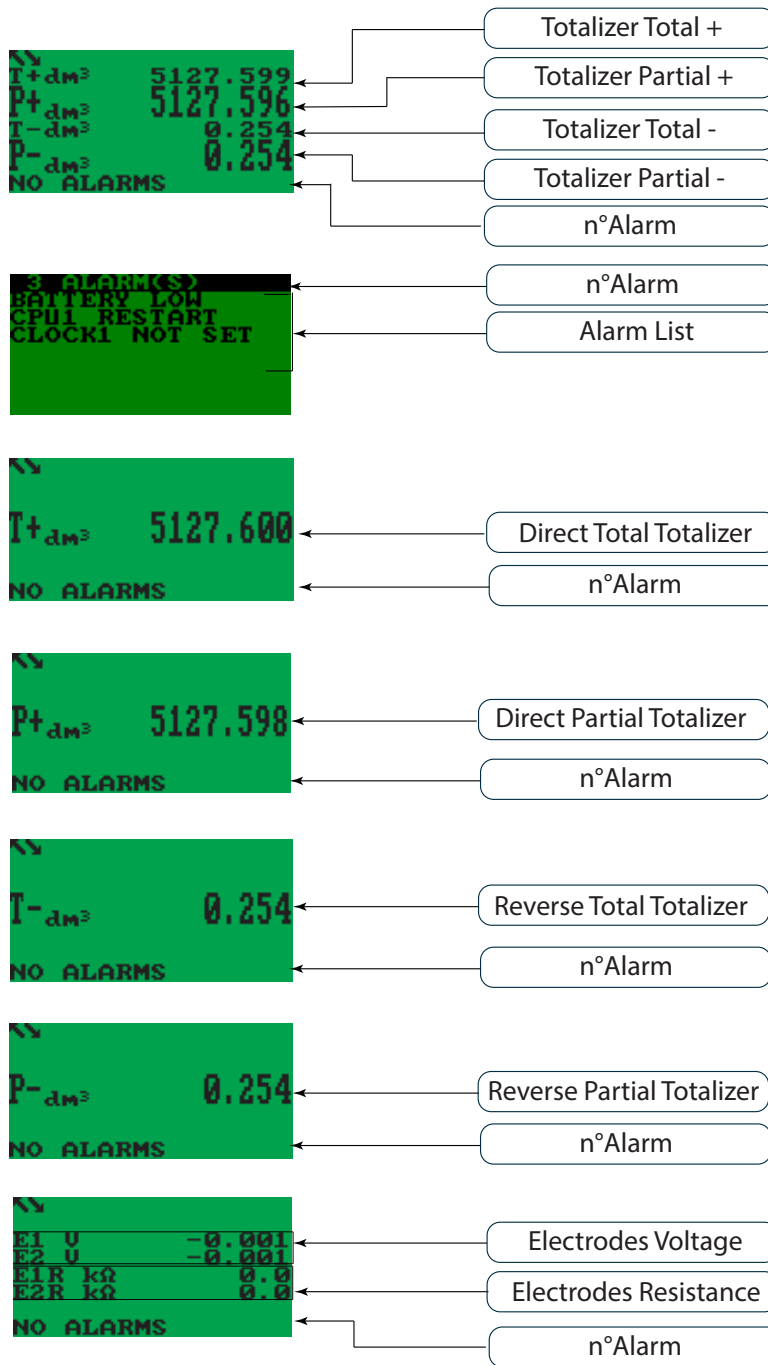

The manufacturer guarantees only English text available on our web site [www.isoil.com](http://www.isoil.com)

## MEANING OF FLAGS

FLAG	DESCRIPTION	FLAG	DESCRIPTION
	EMPTY PIPE		MIN FLOW ALARM
	FILE UPLOAD		MAX FLOW ALARM
	FILE DOWNLOAD		VIDEO TERMINAL CONNECTED
	BATTERY RECHARGE (FLASHING) LOW BATTERY (FIXED)		FLOW RATE OVERFLOW
	FLOW RATE SIMULATION (FLASHING)		PULSE 1 OVERFLOW
	CALIBRATION (FLASHING)		PULSE 2 OVERFLOW
	GENERIC ALARM (FLASHING)		POWERED DEVICE WITH ONE CHARGERS BATTERY (MID-DIRECTIVE)
	GENERAL ALARM ONLY ON PHYSICAL DISPLAY (FLASHING)		
	SIGNAL ERROR		
	EXCITATION ERROR		

## MEANING OF LED COLORS

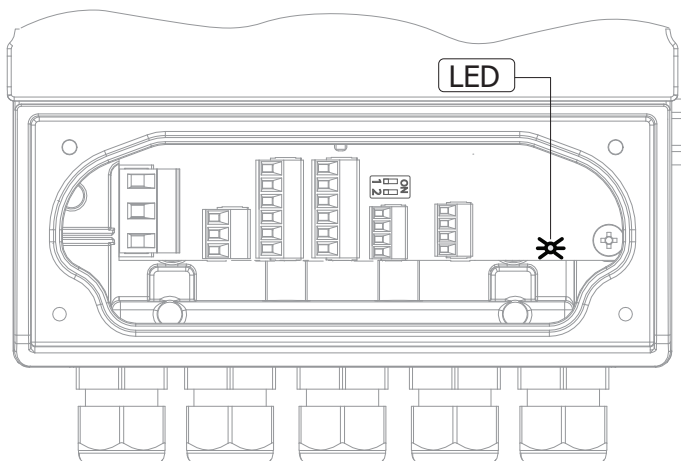

<b>LED Red:</b> Alarm signal
<b>LED Blue:</b> Usb communication enable
<b>LED Green:</b> Functioning system correctly

## ACCESS TO THE CONFIGURATION MENU

The configuration can be done in two different ways:

- ❑ By keypad of converter
- ❑ By MCP interface (Virtual display of instrument)

### Access Via Keypad

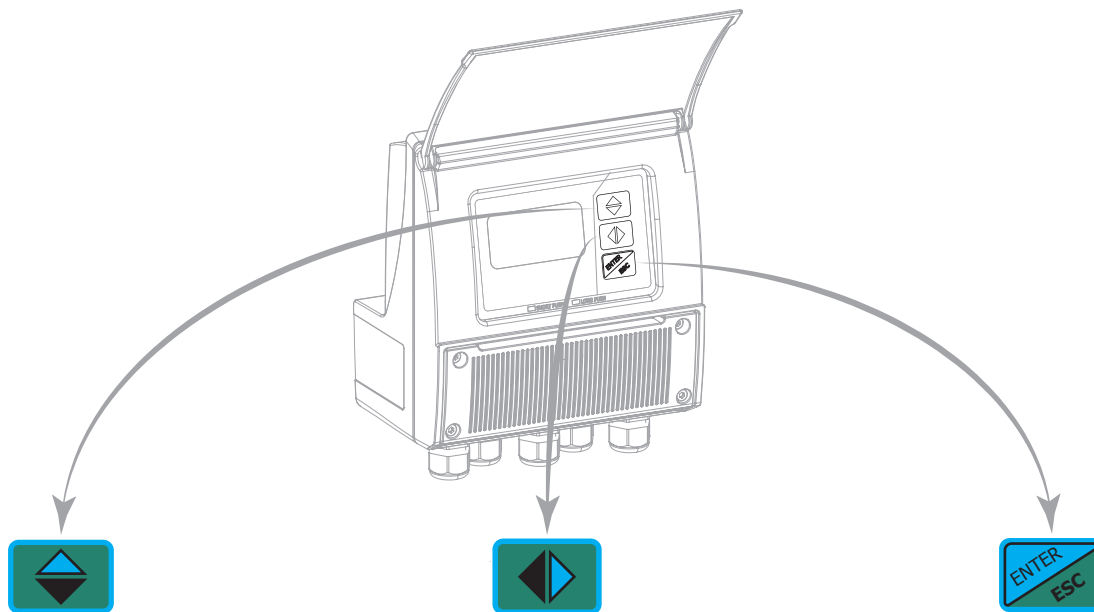

#### SHORT PRESSING (< 1 SECOND):

Increases the numeric figure or the parameter selected by the cursor  
Returns to the previous subject on the menu.

#### LONG PRESSING (> 1 SECOND):

Decreases the numeric figure or the parameter selected by the cursor.  
Proceeds to the next subject on the menu.

#### SHORT PRESSING (< 1 SECOND):

Moves/positions the cursor rightward on the input field. Proceeds to the following subject of the menu.  
Change the display of the process data

#### LONG PRESSING (> 1 SECOND):

Moves/positions the cursor leftward on the input field. Returns to the previous subject on the menu

#### SHORT PRESSING (< 1 SECOND):

Enter /leave the selected function  
Enables the main menu for the instrument configuration  
Cancels the selected function under progress

#### LONG PRESSING (> 1 SECOND):

Leaves the current menu  
Enables the totalizer reset request (when enabled)  
Confirms the selected function.

## ACCESS VIA MCP INTERFACE (VIRTUAL DISPLAY)

MCP is a Windows® software that allows to set all the converter functions and personalize the menu. The MCP program is required for the blind version of the converter. To use MCP interface consult the relevant user manual.

### USB Position for PA6 and aluminium version

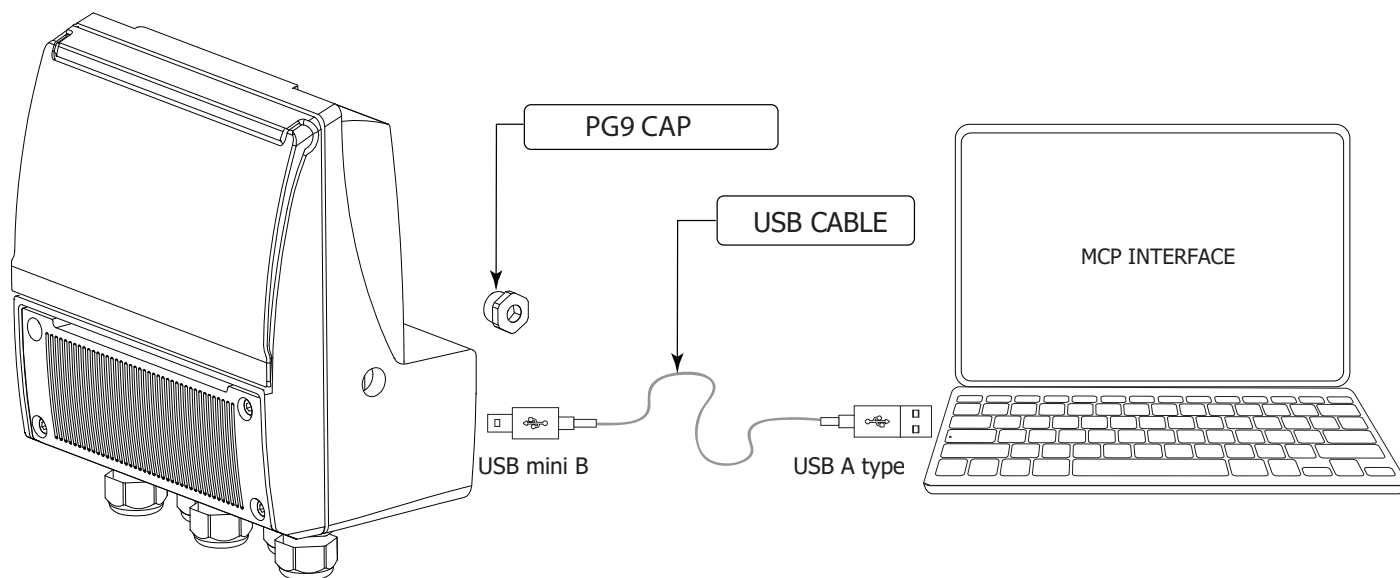

### USB Position for stainless steel version

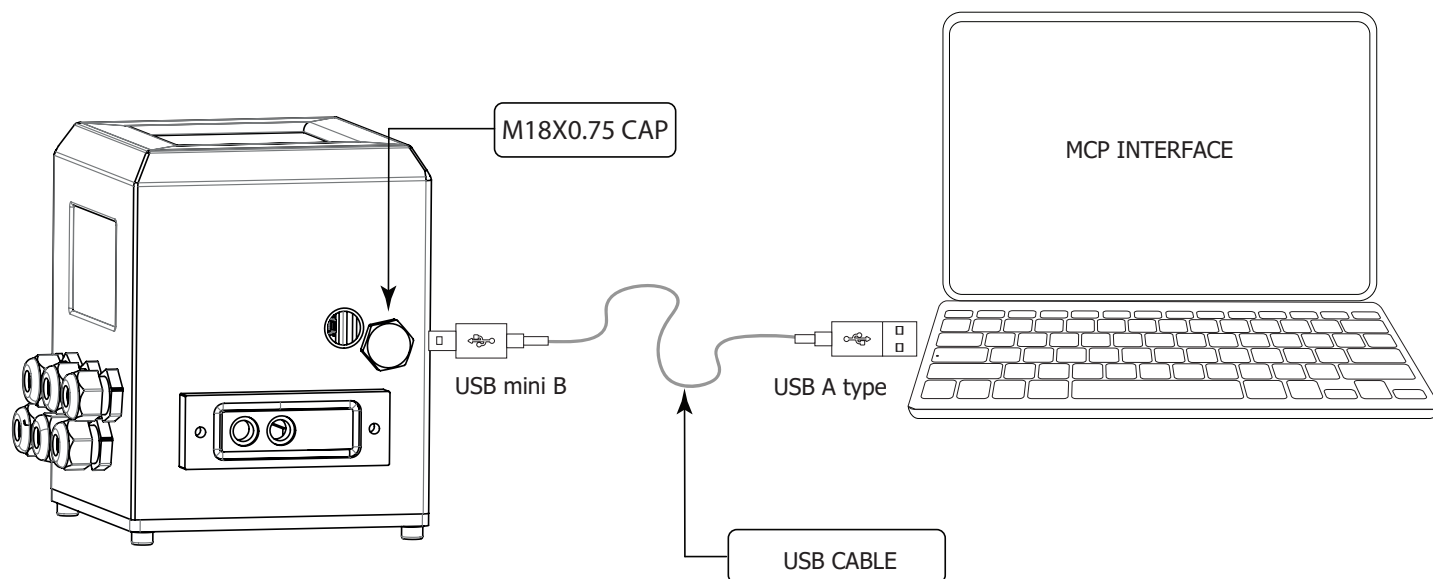

## FLOW RATE VISUALIZATION

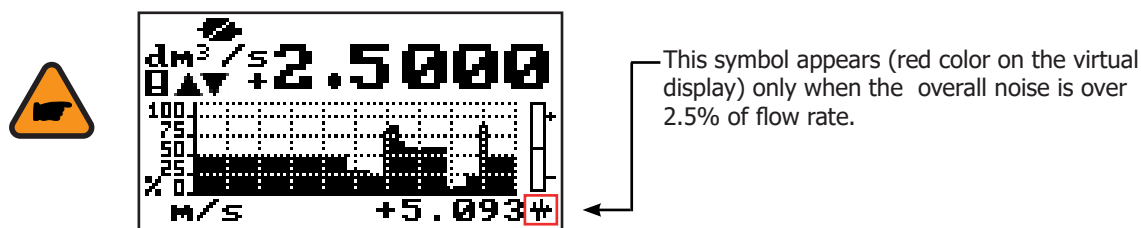

The MV 110 can show a 5 digits display for flow rate units; this mean the maximum flow rate value that can be represented on the display is 99999 (no matter the positioning of the decimal point). The minimum is 0.0025. The representable unit of measure depends on sensor flow rate and diameter; the permitted units are those, that permits the instrument full scale value not exceeding 99999.

Example for DN 300, Full scale value: 3m/s:

- PERMITTED unit of measure** (example): l/s (216.00); m3/h (777.60); m3/s (0.2160)
- NOT PERMITTED unit of measure** (example): l/h (777600)

### Flow rate alert

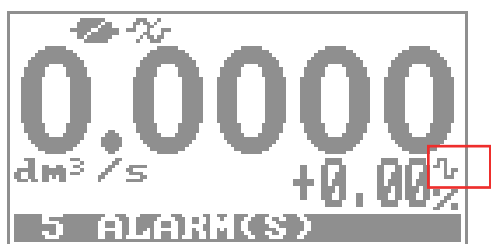

This FLAG becomes active when there is a flow variation (flow rate not stable).

## QUICK START MENU

The QUICK START MENU allows to user immediate access to some of the most commonly used functions; through MCP software it possible customize this menu to make it suitable for the specific application.

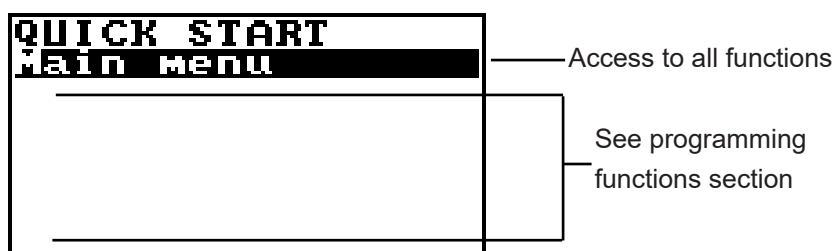

The user has immediate access to the Quick Start menu when the converter is powered up by pressing the Enter key. If access to the quick start menu does not occur, then it could be disabled using the function "9.11" page 36 .

## CONVERTER ACCESS CODE

The access for programming the instrument is regulated by six access levels logically grouped. Every level is protected by a different code.

- Access Level 1-2-3-4 Freely programmable by user

### Access Code Set : Menu 13 System

```

SYSTEM
DEPT. saving= ON
Time zone=h+01.00
2016/04/04-16:07
L1 code=*****
L2 code=*****
L3 code=*****
L4 code=*****
L5 code=*****
L6 code=*****
Restr. access= ON
010.011.012.013
010.011.012.014
255.255.255.000
KI= 0.96469
KS= 1.00000
KR= 1.00000
DAC1 4mA= 02460
DAC1 20mA= 11050
DAC2 4mA= 02460
DAC2 20mA= 11050
Stand-by
FW update
1
1
1
13-System
    
```

```

SYSTEM
L1 code=*****
L2 code=*****
L3 code=*****
L4 code=*****
L5 code=*****
L6 code=*****
0-99999999
    
```

The CODE is Settable by keyboard or MCP interface. Depending on the level of access different display functions will be visible. (See section "FUNCTIONS DESCRIPTION" page 39) These access levels interact with the "Restricted access"

### Restricted Access Set : Menu 13 System

```

SYSTEM
L1 code=*****
L2 code=*****
L3 code=*****
L4 code=*****
L5 code=*****
L6 code=*****
Restr. access= ON
    
```

Settable Values

ON

OFF

**Restrict = ON:** Access permitted only to functions provided for a specific level;

Example: If the operator has a code of access level 3, after having set it, he can change only the functions with level 3 access.

**Restrict = OFF:** It enables to change functions for the selected level and ALL the functions with lower access level.

Example: If the operator has the code of level 3, after having set it, he can change all the functions at level 3 and those at lower levels.

\* WARNING: take careful note of the customized code, since there is no way for the user to retrieve or reset it if lost.

Factory preset access codes:

- L1: 10000000
- L2: 20000000
- L3: 30000000
- L4: 40000000

The following example shows how to change the Full scale by Quick Start menu; the second illustrates how to change the function by the Main menu.

**EXAMPLE: modifying the full scale value from 4dm<sup>3</sup>/s to 5dm<sup>3</sup>/s, from the "Quick start menu"**

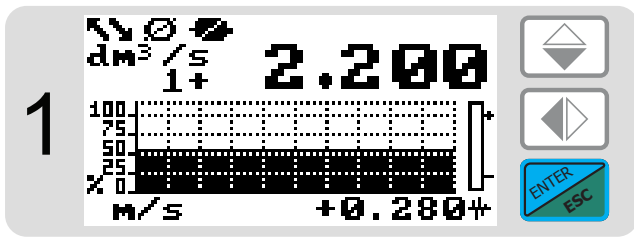

1 Press the ENTER button to access the Quick Start menu

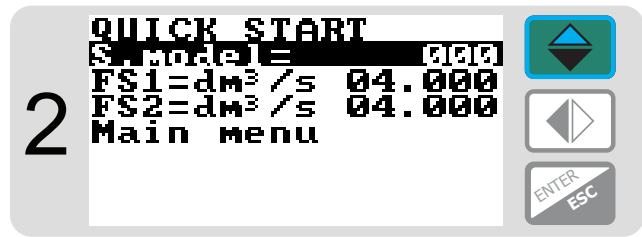

2 Select this function in the list to be edited

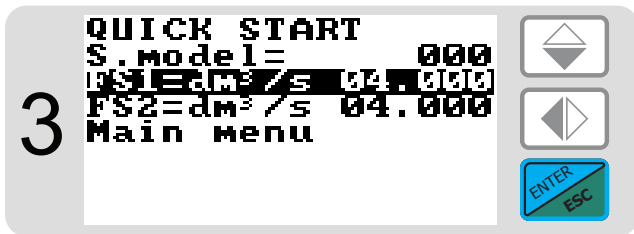

3 Press the ENTER button to select the function.

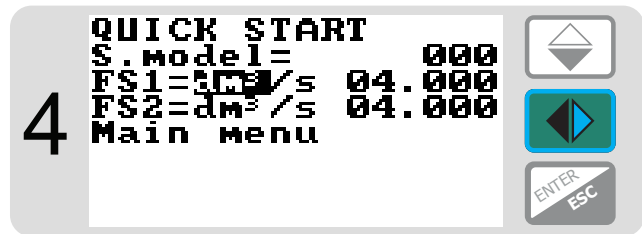

4 Select the value to be changed

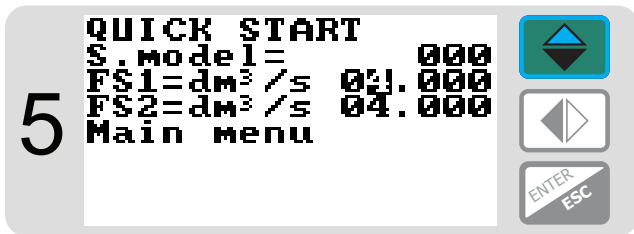

5 Change the value

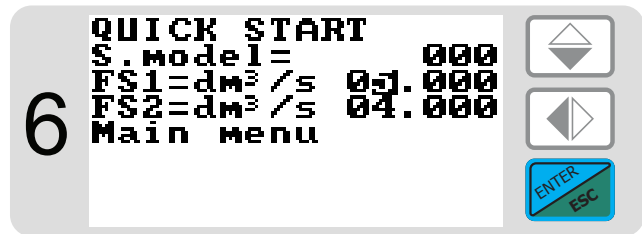

6 Confirm the new value

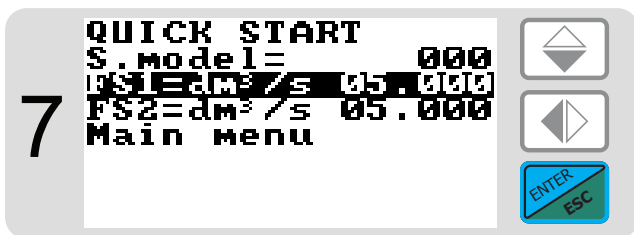

7 Long Push

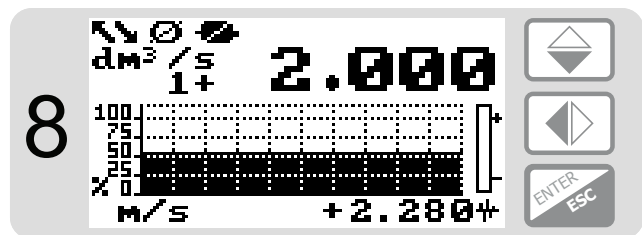

8 Main Page

The manufacturer guarantees only English text available on our web site www.isoil.com

**EXAMPLE: modifying the full scale value from 4dm<sup>3</sup>/s to 5dm<sup>3</sup>/s, from the "Main Menu" (quick start menu enabled)**

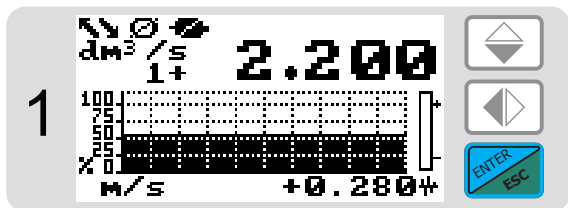

1 Press the ENTER button to access the Quick Start menu

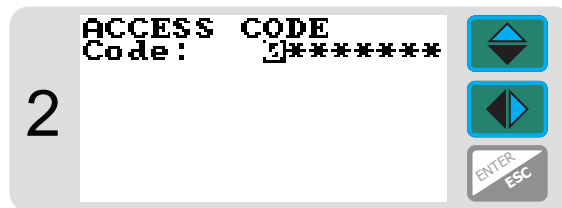

2 Press arrow keys to select the cell in which to insert the number of the access code.

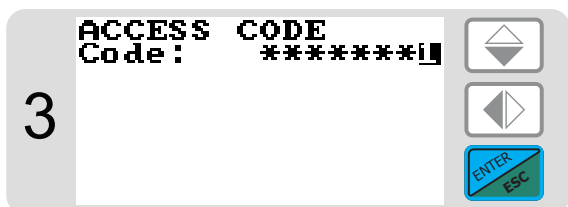

3 Press ENTER button to confirm value.



4 Select "Main Menu"



5 Press the ENTER button to access the Main Menu

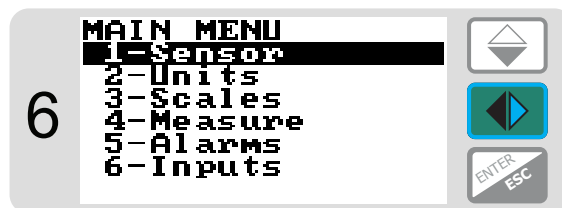

6 Select function



7 Press the ENTER button to access the "Scale Menu"

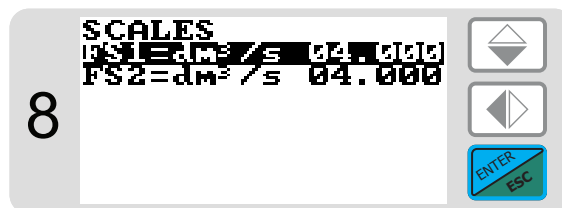

8 Press the ENTER button to access the "Fs1"

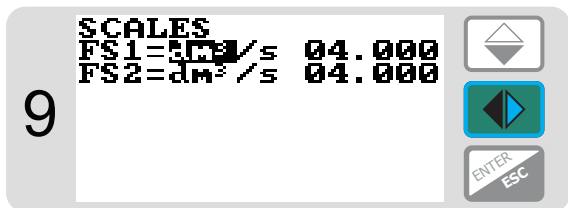

9 Select the value to be changed

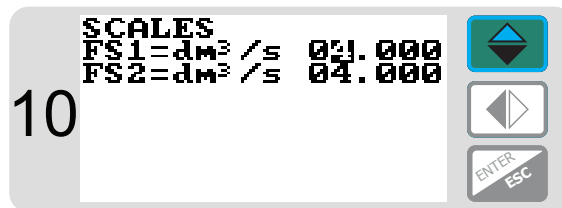

10 Change the value

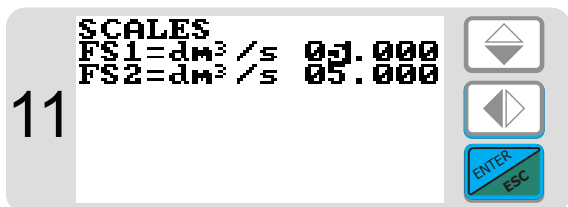

11 Press the ENTER button Confirm the new value

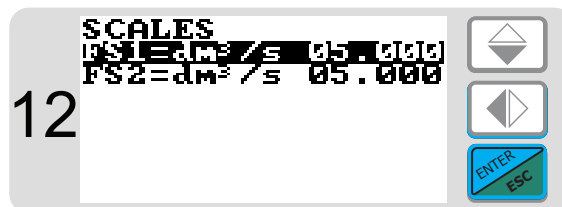

12 Press Esc

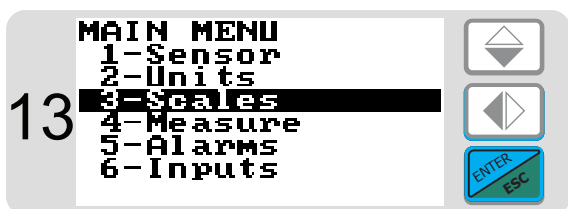

13 Press Esc

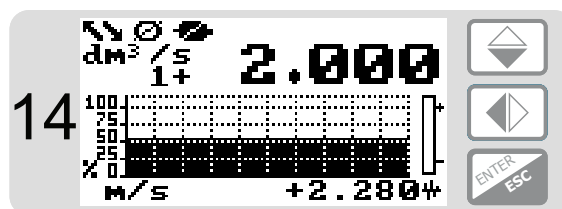

14 Main page

The manufacturer guarantees only English text available on our web site www.isoil.com



SCALES

```

MAIN MENU
1-Sensor
2-Units
3-Scales
4-Measure
5-Alarms
6-Inputs
7-Outputs
SCALES
FS1 g/s          4908.7
FS2 g/s          4908.7
Pls1=g           1000.00
Tpls1=ms         0050.0
Pls2=g           1000.00
Tpls2=g          0050.0
Frq1=Hz          1000.00
Frq2=Hz          1000.00
    
```

- 3.1 Full scale flow rate for range 1
- 3.2 Full scale flow rate for range 2
- 3.3 Output 1 pulse volume value
- 3.4 Output 1 pulse time value
- 3.5 Output 2 pulse volume value
- 3.6 Output 2 pulse time value
- 3.7 Full scale flow rate for range 1
- 3.8 Full scale flow rate for range 2

MEAS.

```

MAIN MENU
1-Sensor
2-Units
3-Scales
4-Measure
5-Alarms
6-Inputs
7-Outputs
MEASURES
Damping          SMART
Cut-off= %       00.1
DT Min.          ON
Autorange        ON
H.imm.inp.       OFF
    
```

- 4.1 Measure damping digital filter
- 4.2 Measure cut-off threshold
- 4.3 Automatic calibration verify
- 4.4 Automatic f.scale range change
- 4.5 High immunity input noise filter

ALARMS

```

MAIN MENU
1-Sensor
2-Units
3-Scales
4-Measure
5-Alarms
6-Inputs
7-Outputs
ALARMS
Max+ = dm3/s     OFF
Max- = dm3/s     OFF
Min+ = dm3/s     OFF
Min- = dm3/s     OFF
Hysteresis=%     03
mA v.alarm=%     000
Hz v.alarm=%     000
    
```

- 5.1 Max.pos.flow r.alarm threshold
- 5.2 Max.neg.flow r.alarm threshold
- 5.3 Min.pos.flow r.alarm threshold
- 5.4 Min.neg.flow r.alarm threshold
- 5.5 Hysteresis on alarm thresholds
- 5.6 Current output value in case of alarm
- 5.7 Frequency value in case of alarm

INPUTS

```

MAIN MENU
1-Sensor
2-Units
3-Scales
4-Measure
5-Alarms
6-Inputs
7-Outputs
INPUTS
T+ reset        OFF
P+ reset        OFF
T- reset        OFF
P- reset        OFF
Count lock      OFF
Meas.lock       OFF
Calibration     OFF
Range change    OFF
    
```

- 6.1 Totaliz.T+ reset input enable
- 6.2 Totaliz.P+ reset input enable
- 6.3 Totaliz.T- reset input enable
- 6.4 Totaliz.P- reset input enable
- 6.5 Totaliz.count lock input enable
- 6.6 Measure zero lock input enable
- 6.7 Calibration func.input enable
- 6.8 Flow rate range change input en.

The manufacturer guarantees only English text available on our web site www.isoil.com

**OUTP.**

```

MAIN MENU
1-Sensor
2-Units
3-Scales
4-Measure
5-Alarms
6-Inputs
7-Outputs
8-Communication
    
```

OUTPUTS			
Out1	PULSES+	7.1	Output 1 function selection
Out2	PULSES-	7.2	Output 2 function selection
Out mA1	4_22 +/-	7.3	Analog current output 1 range
Out mA2	4_22 +/-	7.4	Analog current output 2 range
A1S	4.9087	7.5	Full scale value for analog out1
A2S	4.9087	7.6	Full Scale value for analog out2

```

MAIN MENU
1-Sensor
2-Units
3-Scales
4-Measure
5-Alarms
6-Inputs
7-Outputs
8-Communication
9-Display
10-Data logger
    
```

COMMUNICATION			
HART pr.	05	8.1	HART packet byte preambles
HART O. C.	0N	8.2	HART bus output control
Dev. Addr	001	8.3	Device communication address number
Speed=bps	9600	8.4	MODBUS link speed
Parity=	N0	8.5	MODBUS link parity
Delay=ms	00	8.6	MODBUS reply delay
C. timeout	2	8.7	Maximum delay between chars (frames)
MBUS ID =	220483	8.8	MeterBus Id.Number (Second.Add.)
MBUS Dev.T =	7	8.9	MeterBus Device Type (Media)



**COMM.**

```

MAIN MENU
1-Sensor
2-Units
3-Scales
4-Measure
5-Alarms
6-Inputs
7-Outputs
8-Communication
9-Display
10-Data logger
    
```

DISPLAY			
Language	EN	9.1	Language for all messages
Contrast	5	9.2	Display Contrast adjustment
Disp.time=s	020	9.3	Display/keyboard inactivity time
D.rate=Hz	5	9.4	Display refresh rate
Disp. Fn.	1	9.5	Display function number
Disp.lock	0N	9.6	Display function selection lock
Part. Tot	0N	9.7	Partial totalizer enable
Neg. Tot.	0N	9.8	Negative totalizer enable
Net tot.	0N	9.9	Net totalizer enable
Disp.date	0N	9.10	Time and date display enable
Quick start	0N	9.11	Quick start menu visualization

**DISPLAY**

DATA LOGGER

DATA LOGGER

D.logger en.	ON	10.1	Data logger sampling enable
Meas. units	ON	10.2	Unit of measures recording enable
Field separat.	;	10.3	Field separator character
Decimal separ.	.	10.4	Decimal separator character
Interv.	01:01:00	10.5	Sampling interval
Log T+	ON	10.6	Totaliz.T+ logging enable
Log P+	ON	10.7	Totaliz.P+ logging enable
Log T-	ON	10.8	Totaliz.T- logging enable
Log P-	ON	10.9	Totaliz.P- logging enable
Log TN	ON	10.10	Tot.Net Total logging enable
Log PN	ON	10.11	Tot.Net Partial logging enable
Log Q (UM)	ON	10.12	Flow rate in unit of meas.enable
Log Q (%)	ON	10.13	Flow rate in percentage enable
Log AL.EU	ON	10.14	Alarm events logging enable
Log STR	ON	10.15	Sensor's test results log.enable
Log BTS	ON	10.16	Board temperatures logging en.
Log IBV	ON	10.17	Internal board volt. log.enable
Log EDC	ON	10.18	Electrodes DC voltage log.enable
Log EAC	ON	10.19	Electrodes AC voltage log.enable
Log EIZ	ON	10.20	Electrodes impedance log.enable
Log SCU	ON	10.21	Sensor's coils values log.enable

```

8-Communication
9-Display
10-Data logger
11-Functions
12-Diagnostic
13-System
    
```

FUNCT.

FUNCTIONS

T+ reset		11.1	Totaliz.T+ reset function
P+ reset		11.2	Totaliz.P+ reset function
T- reset		11.3	Totaliz.T- reset function
P- reset		11.4	Totaliz.P- reset function
Load Sens. F. def		11.5	Load sensor factory default val.
Load Conv. F. def		11.6	Load converter factory def. val.
Save Sens. F. def		11.7	Save sensor factory default val.
Save Conv. F. def		11.8	Save converter factory def. val.
Calibration		11.9	Internal circuit calibration

```

7-Display
10-Data logger
11-Functions
12-Diagnostic
13-System
    
```

DIAGN.

DIAGNOSTIC

Self test		12.1	Self test diagnostic function
Test display		12.2	Function tests physical display
Sens. verify		12.3	Sens.verify diagnostic function
Flow sim. =	ON	12.4	Flow rate simulation function
Display measures		12.5	Display internal measured values
Disp. Comm. Vars		12.6	Display comm. diagnostic values
Display graphs		12.7	Display measure as graphs
Gen. sens. set		12.8	Generic sensor parameters set
SD card info		12.9	SD card status informations
Firmware info		12.10	Firmware version information
S/N=	999001	12.11	Board serial number (read only)
WT=	002:21:00 : 22	12.12	Total working time (read only)

```

10-Data logger
11-Functions
12-Diagnostic
13-System
    
```

The manufacturer guarantees only English text available on our web site www.isoil.com

SYSTEM

SYSTEM

```

Dayl. Saving =      ON
Time zone =      h+01:00
                  2016/04/04-16:07
L1 code =      *****
L2 code =      *****
L3 code =      *****
L4 code =      *****
L5 code =      *****
L6 code =      *****
Restr. Access=    ON
                  010.011.012.013
                  010.011.012.014
                  255.255.255.000
RT                0.96469
KS                1.00000
HR                1.00000
DAC1              (°C)
DAC1              (°C)
DAC2              661
DAC2              3327
Stand-by          3453
FW update         14718
    
```

```

M
9-Display
10-Data logger
11-Functions
12-Diagnostic
13-System
    
```

```

13.1 Daylight saving time change
13.2 Localized time zone
13.3 System date and time
13.4 Access level 1 code
13.5 Access level 2 code
13.6 Access level 3 code
13.7 Access level 4 code
13.8 Access level 5 code
13.9 Access level 6 code
13.10 Restricted access level
13.11 Device IP network address
13.12 Client IP network address
13.13 Network mask
13.14 Calibration coefficient KT
13.15 Calibration coefficient KF
13.16 Calibration coefficient KR
13.17 DAC1 out 4mA calibration point
13.18 DAC1 out 20mA calibration point
13.19 DAC2 out 4mA calibration point
13.20 DAC2 out 20mA calibration point
13.21 Stand-by
13.22 firmware update
    
```

The manufacturer guarantees only English text available on our web site www.isoil.com

# FUNCTIONS DESCRIPTION



Here below the explanation on how the rows of menu are described.

Menu visualized on the converter (from 1 to 13)  
**MENU 1 - SENSOR**

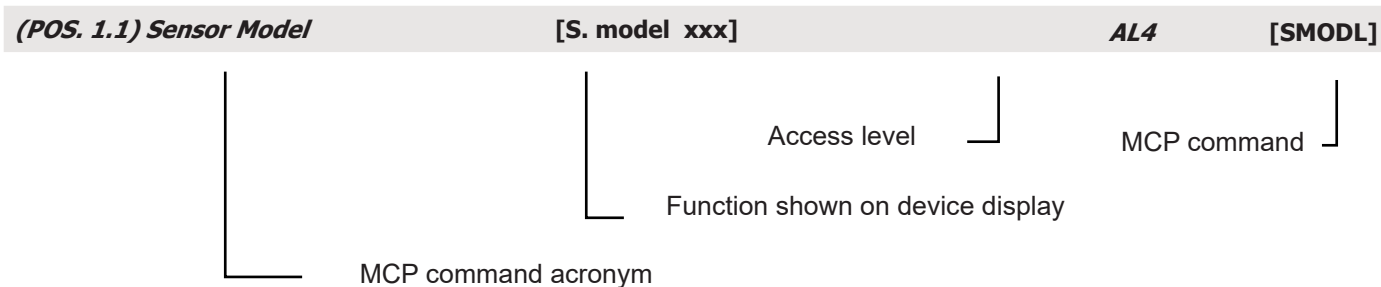

The following picture describes where to find the name of the MCP functions in MCP-software. More info see MCP manual.

The screenshot shows the MCP software interface. On the left, a 'Function list' window displays a tree structure under 'Menu' with items like '[Channel 1 pulse volume value]' and '[Output 1 Pulse Time]'. The main window shows a device display with a graph and numerical values like '0.00' and '+0.00%'. At the bottom, a 'Line editor' window is open, showing 'MCP> OP1PV=' in a text field. A callout box points to this line editor with the text: 'Line editor for the insertion and execution of MCP commands.'

The manufacturer guarantees only English text available on our web site www.isoil.com

## MENU 1 - SENSOR

<b>(POS. 1.1) <i>Sensor MODel</i></b>	<b>[S. model xxx]</b>	<b>AL4</b>	<b>[SMODL]</b>
---------------------------------------	-----------------------	------------	----------------

Enter the first two characters of the serial number of the sensor as on the sensor label.

<b>(POS. 1.2) <i>LIning MAterial Type</i></b>	<b>[Lining= UNSPEC.]</b>	<b>AL4</b>	<b>[LIMAT]</b>
---	--------------------------	------------	----------------

Flow sensor lining material type (PFA; PU-TDI; ALON; PEEK; HR; PP; PA-11; PTFE-HT; PTFE)

<b>(POS. 1.3) <i>Sensor TYPE</i></b>	<b>[S. type= FULL BORE]</b>	<b>AL4</b>	<b>[STYPE]</b>
--------------------------------------	-----------------------------	------------	----------------

Select the sensor type of full-bore or insertion.

<b>(POS. 1.4) <i>Sensor Units TYPE</i></b>	<b>[U.type= METRIC]</b>	<b>AL2</b>	<b>[SUTYP]</b>
--	-------------------------	------------	----------------

Select type of unit of measure of sensor's parameter. Values metric or imperial (inch).

<b>(POS. 1.5) <i>Pipe DIaMeter Value</i></b>	<b>[Diam.= mm xxx]</b>	<b>AL4</b>	<b>[PDIMV]</b>
--	------------------------	------------	----------------

Select the nominal diameter of the sensor (0-2500). ND is written on the sensor label.

<b>(POS. 1.6) <i>CoeFFicient KA</i></b>	<b>[KA= + xx.xxx]</b>	<b>AL4</b>	<b>[CFFKA]</b>
---	-----------------------	------------	----------------

KA factor: calibration coefficient

<b>(POS. 1.7) <i>CoeFFicient KA -</i></b>	<b>[KA= - xx.xxx]</b>	<b>AL4</b>	<b>[CFKAN]</b>
---	-----------------------	------------	----------------

KA factor: calibration coefficient for negative flow. This function is showed only if at least 1 negative KL value is set.

<b>(POS. 1.8) <i>CoeFFicient KZ</i></b>	<b>[KZ= +/- xxxxx]</b>	<b>AL4</b>	<b>[CFFKZ]</b>
---	------------------------	------------	----------------

Calibration Factor. KZ

<b>(POS. 1.9) <i>CoeFFicient KD</i></b>	<b>[KD= +/- xxxxx]</b>	<b>AL4</b>	<b>[CFFKD]</b>
---	------------------------	------------	----------------

Calibration Dynamic Factor.

<b>(POS. 1.10) <i>Sensor Insertion POSition</i></b>	<b>[Ins.position= x]</b>	<b>AL4</b>	<b>[SIPOS]</b>
---	--------------------------	------------	----------------

This function is active with POS.1.3 on "Insertion". See the insertion sensor manual for more details

<b>(POS. 1.11) <i>Sensor Insertion Dynamic KP</i></b>	<b>[KP dynamic= ON/OFF]</b>	<b>AL4</b>	<b>[SIPOS]</b>
---	-----------------------------	------------	----------------

This function is active with POS.POS. 1.3 see page 34 set on insertion. See manual of insertion sensor for more details

<b>(POS. 1.12) <i>CoeFFicient Ki</i></b>	<b>[Ki= +/- xx.xxx]</b>	<b>AL4</b>	<b>[CFFKI]</b>
--	-------------------------	------------	----------------

This function is active with POS. 1.3 see page 34 set on insertion. See manual of insertion sensor for more details

<b>(POS. 1.13) <i>CoeFFicient Kp</i></b>	<b>[Kp dynamic= +/- xxxxx]</b>	<b>AL4</b>	<b>[CFFKP]</b>
--	--------------------------------	------------	----------------

This function is active with POS. 1.3 see page 34 set on insertion. See manual of insertion sensor for more details

**(POS. 1.14) Coefficient *KC*** [KC= +/- xx.xxx] **AL4** [CFFKC]

Calibration Factor. This function is activated if the sensor model is NOT present on the sensors table standard parameters

**(POS. 1.15) Coils *EXCitation Current*** [C.Curr.= mA xxx.x] **AL4** [CEXCC]

Excitation coils current. This function is activated if the sensor model is NOT present on the sensors table standard parameters

**(POS. 1.16) Coils *Regulator PProportional Band*** [C.Reg.PB= xxx] **AL4** [CRPRB]

Proportional band of coils current regulator. This function is activated if the sensor model is NOT present on the sensors table standard parameters

**(POS. 1.17) Coils *Regulator DERivative constant*** [C.Reg. DK = xxx] **AL4** [CRDER]

Derivative constant of coils current regulator. This function is activated if the sensor model is NOT present on the sensors table standard parameters

**(POS. 1.18) *Preamplifier INstalled*** [Preamplif.= ON] **AL4** [PREIN]

This function enable/disable the presence of the preamplifier. The use of the preamplifier inhibit the possibility to use BIV and Empty Pipe Detection.

**(POS. 1.19) *Sampling FREquency*** [S.Freq.= Hz xx] **AL4** [SFREQ]

Measure sampling frequency. This function is activated if the sensor model is NOT present on the sensors table standard parameters

**(POS. 1.20) *Empty Pipe Detection ENable*** [E.P.Detect= ON] **AL3** [EPDEN]

Enables the empty pipe detection function. This function is useful to keep the meter lock to zero when the pipe become empty.

**(POS. 1.21) *Empty Pipe Detection THreshold*** [Z max= Kohm xxxx] **AL4** [EPDTH]

Maximum resistance value at the inputs (electrodes) determine the empty pipe condition. This feature is enabled only if the "13.1" page38 Empty Pipe Detection is ON.

**(POS. 1.22) *Electrodes CLeaNing*** [El.cleaning=OFF] **AL4** [ELCLN]

This function is useful to keep the electrodes clean; the allowed values are: OFF, minimum, average and maximum. It is not recommended to use this function when the liquid has a conductivity less than 100µS/cm (set to OFF).

**(POS. 1.23) *Sensor CAble length Unit of Measure*** [S.cable=m xxx] **AL4** [SCALN]

Lenght of cable between sensor and converter on separate version.

**(POS. 1.24) Signal Error ALarm Time** [S.err.delay=m xxx] **AL4** [SEALT]

Delay before generating error. This function is useful to prevent unexpected lock to zero of measure caused by sporadic events (empty pipe, excitation error, signal error)

**(POS. 1.25) Automatic Sensor VeriFY Enable** [Sens. verify= OFF] **AL3** [ASVFE]

Enable the Automatic sensor verification (see BIV optional function).

**(POS. 1.26) SET KJ values** [KL=XX +/- XXXXXXXXX] **AL4** [SETKJ]

This feature appears only when are met the conditions established by the values assigned to functions DYNRT and DYNST, in detail:

- The flowrate is stable lower the value assigned to the function DYNRT.
- It must have elapsed at least the value assigned to the function DYNST after the last significant change of flow rate above the DYNRT value.

When the above conditions are met, the zero-point calibration function will appear on the display.

ALL THIS FUNCTIONS ARE RESERVED TO THE SERVICE, so the values assigned to these functions are not settable.

**(POS. 1.27) SET KL values** [Zero point cal.] **AL4** [SETKL]

Flow linearization coefficient, reserved to the service. This command is only showed if SMODL = 000.

## MENU 1 - SENSOR: ONLY MCP FUNCTIONS

<b><i>Sensor Coils TiMe A</i></b>	<b>[MCP ONLY]</b>	<b>AL4</b>	<b>[SCTMA]</b>
Reference sensor coil time A			
<b><i>Sensor Coils TiMe B</i></b>	<b>[MCP ONLY]</b>	<b>AL4</b>	<b>[SCTMB]</b>
Reference sensor coil time B			
<b><i>Sensor Coils RESistance</i></b>	<b>[MCP ONLY]</b>	<b>AL4</b>	<b>[SCRES]</b>
Reference sensor coil resistance			
<b><i>Sensor E1 Reference Resistance</i></b>	<b>[MCP ONLY]</b>	<b>AL4</b>	<b>[SE1RR]</b>
Resistance value of E1 electrodes			
<b><i>Sensor E2 Reference Resistance</i></b>	<b>[MCP ONLY]</b>	<b>AL4</b>	<b>[SE2RR]</b>
Resistance value E2 electrodes			
<b><i>Sensor Coils Temperature Reference</i></b>	<b>[MCP ONLY]</b>	<b>AL4</b>	<b>[SCTRF]</b>
sensor data reference temperature. Temperature measured on the coils of the sensor at the time of saving the instrument reference data for B.I.V. function The temperature value in degrees Celsius, which owns the sensor. Note: the temperature must be estimated on the basis of the place of the sensor installation.			

## MENU 2 - UNITS

**WARNING:** The totalizer value is updated and changed depending on the setting of unit value.

The scale change may cause accuracy loss depending of rounding up.

For example, if T +=0,234 liters with 3 decimals, it become T +=0.001 m<sup>3</sup> losing 0.234 liters in rounding up.

<b>(POS. 2.1) <i>Sensor DIameter Unit of Measure</i></b>	<b>[Diam.= mm]</b>	<b>AL2</b>	<b>[SDIUM]</b>
--	--------------------	------------	----------------

Sensor diameter unit of measure (mm or inch)

<b>(POS. 2.2) <i>Sensor CAble LeNght</i></b>	<b>[S.cable= m]</b>	<b>AL2</b>	<b>[SCAUM]</b>
--	---------------------	------------	----------------

Sensor cable length for separate version. Select m or foot.

<b>(POS. 2.3) <i>Flow Rate Unit of Measure Type</i></b>	<b>[FR unit= METRIC]</b>	<b>AL2</b>	<b>[FRMUT]</b>
---	--------------------------	------------	----------------

Flow rate type unit of measure. Select metric or not metric (Imperial units)

<b>(POS. 2.4) <i>PuLse 1 Unit of measure Type</i></b>	<b>[PL1 unit= METRIC]</b>	<b>AL2</b>	<b>[PL1UT]</b>
---	---------------------------	------------	----------------

This function is active with POS. 1.7 see page 34 enable.  
 This function changes the choice of unit of measure POS. 3.3 see page 35  
 Pulse 1 type unit of measure: metric or not metric (Imperial units).

<b>(POS. 2.5) <i>PuLse 2 Unit of measure Type</i></b>	<b>[PL2 unit= METRIC]</b>	<b>AL2</b>	<b>[PL2UT]</b>
---	---------------------------	------------	----------------

This function is active with POS. 7.2 see page 36 enable.  
 This function changes the choice of unit of measure POS. 3.5 see page 35  
 Pulse 2 type unit of measure: metric or not metric Imperial units).

<b>(POS. 2.6) <i>Totalizer Total Positive Unit of measure Type</i></b>	<b>[U.m. T+ = METRIC]</b>	<b>AL2</b>	<b>[TTPUT]</b>
--	---------------------------	------------	----------------

Setting total direct totalizer unit of measure type: metric or not metric Imperial units.  
 This function changes the values unit of measure on POS. 2.7 see page 34

<b>(POS. 2.7) <i>Totalizer Total Positive Unit of Measure</i></b>	<b>[U.m. T+= m<sup>3</sup>]</b>	<b>AL2</b>	<b>[TTPUM]</b>
---	---------------------------------	------------	----------------

Setting total direct totalizer unit of measure.  
 This function is visualized on visualization pages.

<b>(POS. 2.8) <i>Totalizer Total Positive Decimal Point position</i></b>	<b>[N.d.T+= METRIC]</b>	<b>AL2</b>	<b>[TTPDP]</b>
--	-------------------------	------------	----------------

Setting total direct totalizer decimal point position.  
 Example: P+D.P.= 3 visualized value P+ dm<sup>3</sup> 0.000 / P+D.P.= 2 visualized value P+dm<sup>3</sup> 0.00

<b>(POS. 2.8) <i>Totalizer Partial Positive Unit of measure Type</i></b>	<b>[U.m. P+= METRIC]</b>	<b>AL2</b>	<b>[TPPUT]</b>
--	--------------------------	------------	----------------

Setting partial direct totalizer unit of measure type: metric or not metric Imperial units.  
 This function changes the values unit of measure on POS. 2.7 see page 34

<b>(POS. 2.9) <i>Totalizer Partial Positive Unit of Measure</i></b>	<b>[U.m. P+= m<sup>3</sup>]</b>	<b>AL2</b>	<b>[TPPUM]</b>
---	---------------------------------	------------	----------------

Setting partial direct totalizer unit of measure.  
 This function is visualized on visualization pages.

**(POS. 2.10) Totalizer Partial Positive Decimal Point position** [N.d P+= x] AL2 [TPPDP]

Setting partial direct totalizer decimal point position.

Example: P+D.P.= 3 visualized value P+ dm<sup>3</sup> 0.000 / P+D.P.= 2 visualized value P+dm<sup>3</sup> 0.00

**(POS. 2.12) Totalizer Total Negative Unit of measure Type** [U.m T-= METRIC] AL2 [TTNUT]

Setting total reverse totalizer unit of measure type: metric or not metric Imperial units.

This function changes the values unit of measure on POS. 2.7 see page 34

**(POS. 2.13) Totalizer Total Negative Unit of Measure** [U.m T-= dm<sup>3</sup>] AL2 [TTNUM]

Setting total reverse totalizer unit of measure.

This function visualized on visualization pages.

**(POS. 2.14) Totalizer Total Negative Decimal point position** [N.d. T-= x] AL2 [TTNDP]

Setting total reverse totalizer decimal point position.

Example: T- D.P.= 3 visualized value T- dm<sup>3</sup> 0.000 T- D.P.= 2 visualized value T- dm<sup>3</sup> 0.00

**(POS. 2.15) Totalizer Partial Negative Unit of measure Type** [U.m P-= METRIC] AL2 [TPNUT]

This function is active with POS. 9.8 see page 36, enable.

Setting partial reverse totalizer unit of measure type: metric or not metric (Imperial units).

This function changes the values unit of measure on POS. 2.16 see page 34

It is visualized on visualization pages.

**(POS. 2.16) Totalizer Partial Negative Unit of Measure** [U.m P- = dm<sup>3</sup>] AL2 [TPNUM]

Setting partial reverse totalizer unit of measure.

This function visualized on visualization pages.

**(POS. 2.17) Totalizer Partial Negative Decimal Point position** [N.d P- = x] AL2 [TPNDP]

Setting partial reverse totalizer decimal point position.

Example: P- D.P.= 3 visualized value P-dm<sup>3</sup> 0.000  
P- D.P.= 2 visualized value P-dm<sup>3</sup> 0.00

**(POS. 2.18) TeMPerature Unit of Measure** [Temp. unit= C°] AL2 [TMPUT]

Setting temperature unit of measure.

**(POS. 2.19) MaSS Units Enable** [Mass units= ON/OFF] AL2 [MSSUE]

Enable or Disable the selection of mass unit of full scale set.

**(POS. 2.20) Volume to Mass Specific Gravity Coefficient** [Sg= Kg/dm<sup>3</sup> x.xxxx] AL2 [VMSGC]

Setting specific gravity coefficient. This Function is active with POS. 2.19 see page 34, enable.

## MENU 3 - SCALE

(POS. 3.1-2) Flow Rate Full Scale 1-2

[FS1-2= l/s xxxx.x]

AL2

[FRFS1-FRFS2]

The full scale is used to indicate to the maximum meter's flow rate. The full scale should be chosen carefully as it's parameters are used for several other parameters. There are three fields to fill in order to set this parameter, from left to right: 1) unit of measure, 2) time unit of measure and 3) numeric value. The selection is made by positioning the cursor on the field to modify. To change the type unit of measure (metric, Imperial units, mass or volume) see POS. 2.3 see page 34 and POS. 2.19 see page 34 and POS. 2.20 see page 34. The value of Fs1-2 depend nominal diameter POS. 1.4 see page 34. The following tables shown the units of measure available and the conversion factor by comparison with 1dm<sup>3</sup> and 1kg. The converter accepts any kind of combination of units of measure satisfying both the following conditions:

- Numeric field value 99999
- $1/25 \text{ fsmax} \leq \text{numeric field value} \leq \text{fsmax}$ .

Where fsmax is the maximum full scale value corresponding to the sensor, equal to a 10m/s liquid speed. The unit of measures are shown as appear on the display. The Imperial units units are diversified by using capital and small characters.

METRIC	
cm <sup>3</sup>	Cubic centimeter
ml	Milliliter
l	Liter
dm <sup>3</sup>	Cubic decimeter
dal	Decalitre
hl	Hectolitre
m <sup>3</sup>	Cubic meter
ML	Mega Liter

NOT METRIC	
in <sup>3</sup>	Cubic inch
Gal	American gallon
ft <sup>3</sup>	Cubic foot
bbl	Standard barrel
BBL	Oil barrel
hf <sup>3</sup>	Hecto cubic feet
KGL	American Kilo gallon
kf <sup>3</sup>	Kilo cubic feet
ttG	Ten thousand gallons
IGL	Imperial gallon
IKG	Imperial Kilo gallon
Aft	Acre foot
MGL	Mega gallon
IMG	Imperial mega gallon

MASS UNIT NOT METRIC	
Oz	Ounce
Lb	Pound
Ton	Short tons

MASS UNIT METRIC	
g	Gram
kg	Kilogram
t	Ton

When a measure mass unit is set, the specific gravity function is automatically enabled by the system. Please, note that the mass measure is heavily affected by the temperature. With certain liquids this may cause significant measurement errors. The following measure of time units can be selected: s = second, m = minute, h = hour, d = day .

### Double full scale:

The instrument can be configured to have a double full scale: Fs1 and Fs2.

The enabling of double full scale and its selection can be done:

- manually, via input, see function "6.8" page35
- automatically, according to the range, see function "4.4" on page 35

The instrument can indicate the used scale through output (see setting "SCALE" function "7.1" on page 36 and "7.2" on page 36)

### NOTES FOR USING THE MCP INTERFACE

The command FRFS1 =? and command FRS2 = ?, edited by MCP software, return a list of only the unit compatible with the nominal diameter set. If the sensor is insertion type and the diameter is zero, the only possible unit is m/s if the flow rate were chosen metric units, else f/s for the unit of measurement non metric.

**(POS. 3.3-3.5) OutPut 1-2 Pulse Value** **[Pls1-2= dm<sup>3</sup> x.xxxxx]** **AL2** **[OP1PV-OP2PV]**

Pls1 and Pls2 are active when functions "7.1" page 36 and POS. "7.2" page 36 are active and set to "PULSE+"; "PULSE-" or "PULSE+/-". They permit to set pulse value on channel 1 and channel 2. This function allows the user to set a signal (a pulse) to be given from the converter when a defined amount of liquid has passed through the sensor. To set the parameter, complete the 2 fields, from left to right:

1)measure unit, 2) numeric value. The selection is performed by positioning the cursor in the field to be modified.

To change the unit type (metric, British or American, mass or volume) see POS. 2.4 pag. 34 POS. 2.5 pag. 34 and POS. 2.19 pag. 34, POS. 2.20 pag. 34. The value of Pls1-2 depends on nominal diameter POS. 1.4 pag. 34. Only the units described on function POS. 3.1 pag. 35 POS. 3.2 pag. 35 are available to be selected.

**(POS. 3.4-3.6) OutPut1-2 Pulse Time** **[Tpls1-2= ms x.xxxxx]** **AL2** **[OP1PT OP2PT]**

Tpls1 and Tpls2 are active when functions "7.1" page 36 and POS. "7.2" page 36 are active and set to "PULSE+"; "PULSE-" or "PULSE+/-". They permit to set the duration of the pulse generated on channel 1 and 2.

The user must set the corresponding duration of the pulse to be outputed. This value is expressed in milliseconds and has to be between 0,4 and 1250 ms. When the high frequency output is present, then the minimum value can type of device is connected to the converter, the user must verify that the set pulse duration is compatible with the external device processing such pulses. If, for example, an electro-mechanical pulse counter is connected, a minimum pulse time of 0,4 milliseconds can be set.

**ATTENTION:** The converter can not detect problems that may occur; firstly, the pulse is too long the coils may burn out, secondly, if the pulse is too short, the counter may not be able to function, causing damage of the output.

**(POS. 3.7-3.8) Output 1-2 Full scale Frequency** **[Frq1-2= x.xxxxx]** **AL2** **[OU1FF-OU2FF]**

Frq1 and Frq2 are activated with POS. 7.1 see page 36 and POS. 7.2 see page 36 enabled and set to the value freq+/-/+-. Setting duration of the pulse generated on channel 1 and 2.

## MENU 4 - MEASURE

(POS. 4.1) Measure Filter DaMPing

[Damping=OFF/SMART/(TIME)]

AL3

[MFDMP]

This section of manual is extremely important because the correct setting of the filters allows to obtain a proper response of the instrument to the measured flow rate and the specific requirements of use; as a general rule, consider that, starting from Damping = OFF (no filter applied to the measure), successive values, introduce increasing damping. The following diagrams show the instrument's response to changes in flow rate from 0 to 100%, using the different settings of the damping function.

The SMART is an adaptive filter that adapts automatically to most of the processes (recommended value), making the response of the meter very ready to fast changes of flow and at the same time extremely precise and stable for slow variations. It may be convenient to use a constant damping filter time, where there is a pulsating flow (for example generated by peristaltic pumps). With longer times you get a mean value stable, while with short times the measure will closely follow the flow pulses, but consequently more unstable. NOTE: If the rechargeable battery is active, the damping could be set only in "SMART".

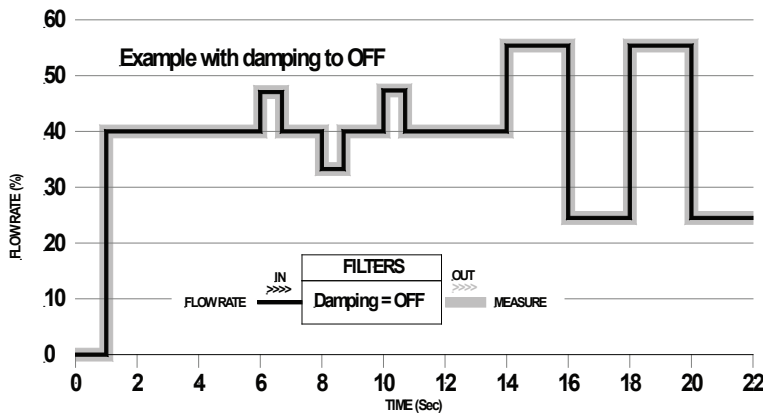

Damping function(OFF). the meter follows the trend of fast changes in flow.

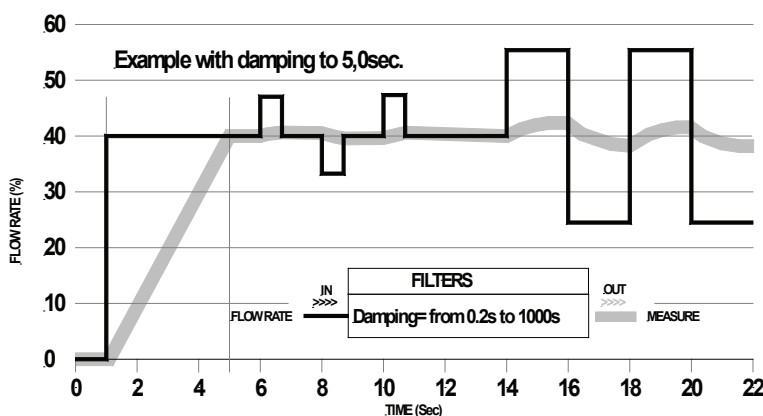

Damping mode based on time (fro 0.2s to 1000s)  
The measure is averaged over a number of samples determined by the value assigned to the dampening function. When the damping parameter is expressed in seconds, the filter works damping the measurement noise and sudden change of flow rate. Increasing the parameter of damping increases the stability of the measurement.

<b>(POS. 4.2) Measure Filter Cut-off Threshold</b>	<b>[Cut-off=% xxx]</b>	<b>AL3</b>	<b>[MFCUT]</b>
--	------------------------	------------	----------------

Setting the low flow cutoff threshold. This function is useful to avoid that flows close to zero, due to the electrical noises from tiny movements of liquid (due for example to vibrations of the pipe) which cause an increasing of the totalizers. The allowed range for this function is 0-25% of full scale set. For most applications a value between 0.5 and 1% is recommended.

<b>(POS. 4.3) Auto CALibration Verify Enable</b>	<b>[Cal.verify=ON]</b>	<b>AL3</b>	<b>[ACAIVE]</b>
--	------------------------	------------	-----------------

This function enables an automatic verification of board's coefficients. As the converter performs continuously a large number of tests, we recommend to use this function only in presence of wide range of temperature. Instead it is NOT recommended to use it when the instrument is used in metering applications (batch).

<b>(POS. 4.4) Auto RaNGE Enable</b>	<b>[Autorange=ON/OFF]</b>	<b>AL3</b>	<b>[ARNGE]</b>
-------------------------------------	---------------------------	------------	----------------

Enables the automatic change of scale. The meter may have two different working ranges in order to suit to the variable process conditions. In order to get the best results out of this function it is important range N.2 (Fs2) if enabled is bigger than N.1 (Fs1). When the flow rate increases and reaches the 100% of the full scale 1, then the meter automatically switches to scale 2. When the flow rate decreases again reaching a value on scale 2 equal to the 90% of full scale N.1, then the active scale is 1 again. Allowed values for this parameter: ON/OFF.

Notice: when the autorange is enabled, is not allow to use the manual range change (POS. 6.6 see page 35 ).

This function does NOT increase the accuracy of the measure; its aim is to increase the resolution of 4/20 mA when the meter work at very low flow rates (typical case the flow rate of water distribution with daytime flow much higher than the night flow).

<b>(POS. 4.5) High immunity INPUTS</b>	<b>[H.imm. inp.]</b>	<b>AL4</b>	<b>[HIINP]</b>
--	----------------------	------------	----------------

The HIINP function (INPut High Immunity filter) introduces a hardware filter to be used ONLY IN CASE OF ABSOLUTE NECESSITY, when the measure is absolutely unstable or it is NOT possible to make the measure, and every possible attempt to reduce or eliminate the noise do not give a positive result, with particular attention of instrument ground connection. When this function is activated (HIINP = ON) the measure will be influenced by an unavoidable error estimated around 1%.

## MENU 4 - measure: ONLY MCP FUNCTIONS

<b>Measure Filter Cut-off Threshold 2</b>	<b>[MCP ONLY]</b>	<b>AL3</b>	<b>[MFCT2]</b>
---	-------------------	------------	----------------

Setting the low flow cutoff threshold, it is similar to the function in 4.2. The value of this function is NOT visible on display but only with MCP command.

<b>DYNamic Sample Analysis</b>	<b>[MCP ONLY]</b>	<b>AL4</b>	<b>[DYNSA]</b>
--------------------------------	-------------------	------------	----------------

Reserved to the service

<b>DYNamic Sample Time</b>	<b>[MCP ONLY]</b>	<b>AL4</b>	<b>[DYNST]</b>
----------------------------	-------------------	------------	----------------

Reserved to the service

<b>DYNamic Range Threshold</b>	<b>[MCP ONLY]</b>	<b>AL4</b>	<b>[DYNRT]</b>
--------------------------------	-------------------	------------	----------------

Reserved to the service

## MENU 5 - ALARMS

**(POS. 5.1) Flow Rate Alarm maX Positive** [Max+=XXXXX] **AL3** [FRAXP]

Maximum value alarm set for direct flow rate set. When the flow rate value exceeds such a threshold, then an alarm message is generated. The value of this parameter is expressed in technical units and can be set from 0 to fmax, with resolution 1/250 of fmax. Setting this parameter to OFF disables the alarm start.

**(POS. 5.2) Flow Rate Alarm maX Negative** [Max-=XXXXX] **AL3** [FRAXN]

Maximum value alarm set for reverse flow rate set. When the flow rate value exceeds such a threshold, then an alarm message is generated. The value of this parameter is expressed in technical units and can be set from 0 to fmax, with resolution 1/250 of fmax. Setting this parameter to OFF disables the alarm start.

**(POS. 5.3) Flow Rate Alarm miN Positive** [Min+=XXXXX] **AL3** [FRANP]

Minimum value alarm set for reverse flow rate set. When the flow rate value falls below such a threshold, then an alarm message is generated. The value of this parameter is expressed in technical units and can be set from 0 to fmax, with resolution 1/250 of fmax. Setting this parameter to OFF disables the alarm start.

**(POS. 5.4) Flow Rate Alarm miN Negative** [Min-=XXXXX] **AL3** [FRANN]

Minimum value alarm set for reverse flow rate set. When the flow rate value falls below such a threshold, then an alarm message is generated. The value of this parameter is expressed in technical units and can be set from 0 to fmax, with resolution 1/250 of fmax. Setting this parameter to OFF disables the alarm start.

**(POS. 5.5) Alarm Thresholds HYSteresis** [Hysteresis=XXXXX] **AL3** [ATHYS]

Hysteresis threshold set for the minimum and maximum flow rate alarms. The value of this parameter is expressed in technical units and can be set from 0 to 1/250 of the fmax at 10 m / s.

**(POS. 5.6) Output Current Alarm Condition Value** [mA V.alarm =% XXX] **AL3** [OCACV]

The output current signal can be specified by the user in case of failure of either, empty pipe, coils interrupted, or ADC error. The signal current is set as a percentage (0 to 125%) of the 0/4-20mA current. 125% corresponds to 24mA and does not depend on the selected range (0-20/4-20mA).

The NAMUR NE43 recommendation asks for a alarms signalling value for the current output lower than 3.6mA (<18%) or bigger than 21mA (>105%). It would then be preferable to set the value of this function at the 10%, so that the current value in case of the a.m. cases would be 2 mA, allowing the following diagnostics:

current < 2mA - 5%: line interrupted, power supply failure or faulty converter;

2mA -5% \* current \* 2mA + 5%: hardware alarm;

4mA \* current \* 20mA: normal working range;

20mA < current \* 22mA: out of range, measure above 100% f.s.

**(POS. 5.7) Output Frequency Alarm Condition Value** [Hz V.alarm=%XXX] **AL3** [OFACV]

This function is active with POS. 7.1 see page 36 and POS. 7.2 see page 36 enable to ( FREQ.+ , FREQ.- , FREQ.± )  
To set the frequency value assigned to the on/off output in one or more of the following failure cases:

Empty pipe; Coils interrupted ; ADC error. Allowable range is from 0 to 125% of the frequency full scale value. Although there are no specific rules regulating cases such as these, it would be convenient to use the failure information as follows:

0% Hz \* frequency \* 100% f.s.: normal working range;

100% f.s. < frequency \* 110% f.s.: overflow, measure above the 100% of the f.s.;

115% f.s. \* frequency \* 125% f.s.: hardware alarm condition.

## MENU 6 - INPUTS

**(POS. 6.1-2) Volume Totalizer Total /Partial Positive reset Enable**      [T/P+/RESET=ON/OFF]      **AL3**      [VTTPE] [VTPPE]

When one of this function is enabled, the related totalizer + may be reset through the on/off input.

**(POS. 6.3-4) Volume Totalizer Total /Partial Negative reset Enable**      [T/P-/RESET=ON/OFF]      **AL3**      [VTTNE] [VTPNE]

When one of this function is enabled, the related totalizer - may be reset through the on/off input.

**(POS. 6.5) Totalizers Count Lock Input Enable**      [COUNT LOCK= ON/OFF]      **AL3**      [TCLIE]

Totalizers counting lock command enable. When this function is active, applying a voltage on the on/off input terminals the system stops the totalizers no matter which is the flow rate.

**(POS. 6.6) MeaSure Lock Input Enable**      [Meas.lock=ON/OFF]      **AL3**      [MSLIE]

When this function is active (ON), applying a voltage on the on input terminals, the measurement is stopped, the meter will display zero flow.

**(POS. 6.7) CALibration Input Enable**      [Calibration=ON/OFF]      **AL3**      [CALIE]

When this function is active, applying a voltage on the on/off input terminals the meter performs a autozero calibration cycle. ATTENTION: If the voltage pulse is less than 1 sec., the meter performs a calibration cycle to compensate possible thermal drifts. If the voltage pulse is more 1 sec, the meter performs a zero calibration measure. To perform the calibration it is absolutely necessary for the sensor to be full of liquid and that the liquid is perfectly still. Even very small movement of the liquid may affect the result of the calibration, and, consequently, the accuracy of the system.

**(POS. 6.8) Scale Range Change Input Enable**      [RANGE CHANGE=ON/OFF]      **AL3**      [SRCIE]

Range change external command enable. When this function is enabled, applying a voltage on the on/off input terminals the meter switches to the second measuring range (Fs2).

N.B.: the autorange doesn't allow to use the manual range change see (POS. 4.4 see page 35).

## MENU 7 - OUTPUTS

### *(POS. 7.1) OUTput 1 Function*

[Out1=XXXXXX]

AL3

[OUT1F]

Function choice corresponding to digital Output 1. The functions are listed in the table below.

### *(POS. 7.2) OUTput 2 Function*

[Out2=XXXXXX]

AL3

[OUT2F]

Function choice corresponding to digital Output 2. The functions are listed in the table below.

## FUNCTIONS FOR OUTPUTS 1 AND 2

- OFF:** DISABLE
- MAX AL. +:** MAX DIRECT FLOW RATE OUTPUT (ENERGIZED = AL. OFF)
- MIN AL. +:** MIN DIRECT FLOW RATE OUTPUT (ENERGIZED = AL. OFF)
- MAX AL.-:** MAX INVERSE FLOW RATE OUTPUT (ENERGIZED = AL. OFF)
- MIN AL.-:** MIN INVERSE FLOW RATE OUTPUT (ENERGIZED = AL. OFF)
- MAX/MIN-:** MAX/MIN INVERSE FLOW RATE OUTPUT (ENERGIZED = AL. OFF)
- MAX/MIN+/-:** MAX/MIN DIRECT FLOW RATE OUTPUT (ENERGIZED = AL. OFF)
- P.EMPTY:** EMPTY PIPE ALLARM OUTPUT (ENERGIZED = AL. OFF)
- AL.SYSTEM:** SUM OF ALL ALARMS "energized interrupted " AND "error input signal "
- OVERFLOW:** OUT OF RANGE ALLARM OUTPUT (ENERGIZED = FLOWRATE OK)
- ALL ALARMS:** SUM OF ALL ALARMS POSSIBLE
- MANUAL:** OUTPUT MAY TAKE A STATE EMPLOYEE FROM AN EXTERNAL CONTROL (MCP,MODBUS, ecc)
- FLOW RATE SIGN.:** FLOW DIRECTION (ENERGIZED WHEN FLOW IS NEGATIVE)
- SCALE:** INDICATION SCALE
- FREQ.+:** FREQUENCY POSITIVE FLOWRATE
- FREQ.-:** FREQUENCY NEGATIVE FLOWRATE
- FREQ.+/-:** FREQUENCY POSITIVE/NEGATIVE FLOWRATE
- PULSES.+:** PULSE POSITIVE FLOW RATE
- PULSES.-:** PULSE NEGATIVE FLOW RATE
- PULSES+/-:** PULSE NEGATIVE/POSITIVE FLOW RATE

### *(POS. 7.3-4) Analog Output 1/2 Configuration*

[Out mA1/2=X\_XX XXX]

AL3

[AO1CF] [AO2CF]

This function sets the current output 1 and 2. This function is optional and will not appear unless the option has been requested. There are three fields to modify for this function:

- Scale zero: 4 or 0mA
- Full scale: 20 or 22mA
- Field: + = positive, - = negative, blank = both, -0+ = central zero scale

The values corresponding to the scale points are shown in the following chart:

CURRENT VALUES IN mA ASSOCIATE TO THE % FULL SCALE VALUE					
POSSIBLE FIELD	REVERSE FLOW VALUE		ZERO	DIRECT FLOW VALUE	
	≤-110%	-100%	0%	+100%	≥+110%
Out.mA = 0 ÷ 20 +	0	0	0	20	20
Out.mA = 0 ÷ 22 +	0	0	0	20	22
Out.mA = 4 ÷ 20 +	4	4	4	20	20
*Out.mA = 4 ÷ 22 +	4	4	4	20	21.6
Out.mA = 0 ÷ 20 -	20	20	0	0	0
Out.mA = 0 ÷ 22 -	22	20	0	0	0
Out.mA = 4 ÷ 20 -	20	20	4	4	4
Out.mA = 4 ÷ 22 -	21.6	20	4	4	4
Out.mA = 0 ÷ 20	20	20	0	20	20
Out.mA = 0 ÷ 22	22	20	0	20	22
Out.mA = 4 ÷ 20	20	20	4	20	20
Out.mA = 4 ÷ 22	21.6	20	4	20	21.6
Out.mA = 0 ÷ 20 -0+	0	0	10	20	20
Out.mA = 0 ÷ 22 -0+	0	1	11	21	22
**Out.mA = 4 ÷ 20 -0+	4	4	12	20	20
Out.mA = 4 ÷ 22 -0+	2	4	12	20	22

In hardware alarm conditions "HARDW AL." (interrupted coils, empty pipe, measure error) the current value is programmed by the function "mA v.fault" (pos. 5.6) and it is expressed as percentage of a fixed current range, where: 0% = 0mA and 110% = 22mA.

\* Example 1: out 4-22 +

\*\* Example 2: out 4-20 -0+

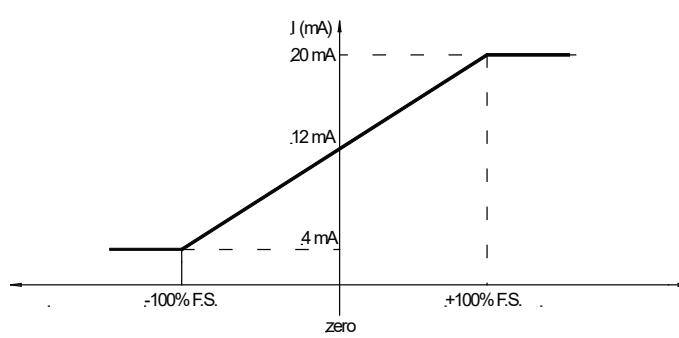
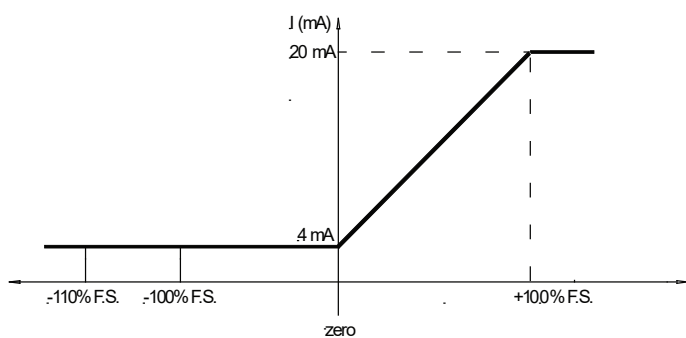

**(POS. 7.5) Analog Output 1 Full Scale**

[A1S= dm/s x.xxxxx]

AL3

[A01FS]

It allows to set the full scale value for analog output 1 independently from the main scale of the instrument.

**(POS. 7.6) Analog Output 2 Full Scale**

[A2S= dm/s x.xxxxx]

AL3

[A02FS]

It allows to set the full scale value for analog output 2 independently from the main scale of the instrument.

## MENU 8 - COMMUNICATION

<b>(POS. 8.1) HART Preambles</b>	<b>[HART pr.=XXXXXX]</b>	<b>AL3</b>	<b>[HARTP]</b>
----------------------------------	--------------------------	------------	----------------

Number of preamble (Hart function)

<b>(POS. 8.2) HaRT Output Control</b>	<b>[HART O.C=ON/OFF]</b>	<b>AL3</b>	<b>[HRTOC]</b>
---------------------------------------	--------------------------	------------	----------------

Hart bus output control 4-20mA.



<b>(POS. 8.3) DeVice ADDRESS</b>	<b>[Dev. Addr=XXXXXX]</b>	<b>AL3</b>	<b>[DVADD]</b>
----------------------------------	---------------------------	------------	----------------

Device communication address number.

<b>(POS. 8.4) MoDbus Speed</b>	<b>[Speed=XXXXXX]</b>	<b>AL3</b>	<b>[MDBSP]</b>
--------------------------------	-----------------------	------------	----------------

Modbus link speed.

<b>(POS. 8.5) Modbus Parity</b>	<b>[Parity=XXXXXX]</b>	<b>AL3</b>	<b>[MDBPA]</b>
---------------------------------	------------------------	------------	----------------

Modbus link parity.

<b>(POS. 8.6) Modbus Delay</b>	<b>[Delay=XXXXXX]</b>	<b>AL3</b>	<b>[MDBDL]</b>
--------------------------------	-----------------------	------------	----------------

Modbus replay delay.

<b>(POS. 8.7) Modbus chars Timeout</b>	<b>[C. timeout=X]</b>	<b>AL3</b>	<b>[MDBCT]</b>
--	-----------------------	------------	----------------

Maximun delay between chars (frames).

<b>(POS. 8.8) MeTerbus Identifier Number</b>	<b>[MBUS ID=220483]</b>	<b>AL3</b>	<b>[MTINR]</b>
--	-------------------------	------------	----------------

MeterBus Identifier Number (Secondary.Address)

<b>(POS. 8.9) MeTerbus Device TYpe</b>	<b>[MBUS Dev.T=7]</b>	<b>AL3</b>	<b>[MTDTY]</b>
--	-----------------------	------------	----------------

MeterBus Device Type (Media)

## MENU 9 - DISPLAY

<b>(POS. 9.1) Layout LANGuage</b>	<b>[Language= ITA/EN]</b>	<b>AL1</b>	<b>[LLANG]</b>
Choice of the language. There are 8 languages available: <b>GB</b> = English, <b>IT</b> = Italian, <b>TR</b> = Turkish, <b>PL</b> = Polish, <b>DE</b> = German, <b>FR</b> = French, <b>PT</b> = Portuguese, <b>ES</b> = Spanish.			
<b>(POS. 9.2) Display CoNTRast</b>	<b>[Contrast= x]</b>	<b>AL1</b>	<b>[DCNTR]</b>
Display contrast set. The contrast can change according to the room temperature. The allowed range is from 0 to 9.			
<b>(POS. 9.3) KeyBoard TiMeout Time</b>	<b>[Disp. time=s xxx]</b>	<b>AL1</b>	<b>[KBTMT]</b>
This function set display/keyboard inactivity. The set values are from 020 to 255 second.			
<b>(POS. 9.4) DISplay Refresh Frequency</b>	<b>[D.rate=Hz xx]</b>	<b>AL1</b>	<b>[DISRF]</b>
Frequency of the display data update. This parameter effects only the display layout and not the response time of the meter itself. The possible choices are: 1/2/5/10 Hz.			
<b>(POS. 9.5) DISplay Function Number</b>	<b>[Disp.fn= x]</b>	<b>AL2</b>	<b>[DISFN]</b>
This function sets the display of the page making it visible when you start the display. For each display page is associated with a number that corresponds to the position.			
<b>(POS. 9.6) Display function LOck Enable</b>	<b>[Disp.lock= x]</b>	<b>AL2</b>	<b>[DLOKE]</b>
This function locks the scrolling of the display pages selected by the setting. POS. 9.5 see page 36 function.			
<b>(POS. 9.7) Partial TOTalizers Enable</b>	<b>[Part. tot= ON]</b>	<b>AL2</b>	<b>[PTOTE]</b>
This function enables the display of partial totalizer in visualization pages			
<b>(POS. 9.8) NEGative value Totalizers Enable</b>	<b>[Neg. tot= ON]</b>	<b>AL2</b>	<b>[NEGTE]</b>
This function enables the display of negative totalizer in visualization pages			
<b>(POS. 9.9) Net Value ToTalizers Enable</b>	<b>[Net. tot= ON]</b>	<b>AL2</b>	<b>[NVTTE]</b>
This function enables the display of net totalizer in visualization pages			
<b>(POS. 9.10) Date And Time Display Enable</b>	<b>[Disp.Date= ON]</b>	<b>AL2</b>	<b>[DATDE]</b>
This function enables the display of date and time in visualization pages			
<b>(POS. 9.11) Quick STart Menu Enable</b>	<b>[Quick start= ON]</b>	<b>AL2</b>	<b>[QSTME]</b>
This function enables the quick start menu.			

## MENU 10 - DATA LOGGER

<b><i>(POS. 10.1) Data LOGger Enable</i></b>	<b>[D.logger en= /OFF]</b>	<b>AL3</b>	<b>[DLOGE]</b>
--	----------------------------	------------	----------------

This function enables data logger.

The following functions are activated by [D.loger en= ON]

<b><i>(POS. 10.2) Data Logger Units of Measure Enable</i></b>	<b>[Meas. units= ON]</b>	<b>AL3</b>	<b>[DLUME]</b>
---	--------------------------	------------	----------------

Unit of measure recording enable

<b><i>(POS. 10.3) Data Logger Field Separator Character</i></b>	<b>[Field separ.= ;]</b>	<b>AL3</b>	<b>[DLFSC]</b>
---	--------------------------	------------	----------------

This function will set the separator character between data logger data.

<b><i>(POS. 10.4) Data Logger Decimal Separator Character</i></b>	<b>[Decim.separ.= .]</b>	<b>AL3</b>	<b>[DLDSC]</b>
---	--------------------------	------------	----------------

This function will set the separator character between data logger number value.

<b><i>(POS. 10.5) Data Logger Sample Interval</i></b>	<b>[Interv.= xx:xx:xx]</b>	<b>AL3</b>	<b>[DLGSI]</b>
---	----------------------------	------------	----------------

Sampling interval. This function set the log frequency. [Interv.= Hours : Minutes: Seconds]

<b><i>(POS. 10.6) Data logger Totalizer Total Positive Enable</i></b>	<b>[Log T+= ON]</b>	<b>AL3</b>	<b>[DTTPE]</b>
---	---------------------	------------	----------------

Enable logging of total direct totalizer.

<b><i>(POS. 10.7) Data logger Totalizer Partial Positive Enable</i></b>	<b>[Log P+= ON]</b>	<b>AL3</b>	<b>[DTPPE]</b>
---	---------------------	------------	----------------

Enable logging of partial direct totalizer.

<b><i>(POS. 10.8) Data logger Totalizer Total Negative Enable</i></b>	<b>[Log T-= ON]</b>	<b>AL3</b>	<b>[DTTNE]</b>
---	---------------------	------------	----------------

Enable logging of total reverse totalizer

<b><i>(POS. 10.9) Data logger Totalizer Partial Negative Enable</i></b>	<b>[Log P-= ON]</b>	<b>AL3</b>	<b>[DTPNE]</b>
---	---------------------	------------	----------------

Enable logging of partial reverse totalizer

<b><i>(POS. 10.10) Data Logger totalizer Total Net Enable</i></b>	<b>[Log TN= ON]</b>	<b>AL3</b>	<b>[DLTNE]</b>
---	---------------------	------------	----------------

Enable logging of total net totalizer

<b><i>(POS. 10.11) Data Logger totalizer Partial Net Enable</i></b>	<b>[Log PN= ON]</b>	<b>AL3</b>	<b>[DLPNE]</b>
---	---------------------	------------	----------------

Enable logging of partial net totalizer

<b><i>(POS. 10.12) Data logger Flow rate in Technical Units Enable</i></b>	<b>[Log Q(UM)= ON]</b>	<b>AL3</b>	<b>[DFTUE]</b>
--	------------------------	------------	----------------

Enable logging of flow rate in unit of measure

<b><i>(POS. 10.13) Data logger Flow rate in PerCentage Enable</i></b>	<b>[Log Q(%)= ON]</b>	<b>AL3</b>	<b>[DFPCE]</b>
---	-----------------------	------------	----------------

Enable recording of the flow rate as a percentage of full scale value set.

<b><i>(POS. 10.14) Data logger ALarm Events Enable</i></b>	<b>[Log AL.EV= ON]</b>	<b>AL3</b>	<b>[DALEE]</b>
--	------------------------	------------	----------------

Enable logging of alarm events

<b><i>(POS. 10.15) Data logger Sensor Test Results Enable</i></b>	<b>[Log STR= ON]</b>	<b>AL6</b>	<b>[DSTRE]</b>
Enable logging of sensor test results			
<b><i>(POS. 10.16) Data logger Board TemperatureS Enable</i></b>	<b>[Log BTS= ON]</b>	<b>AL6</b>	<b>[DBTSE]</b>
Enable logging of board temperature			
<b><i>(POS. 10.17) Data logger Internal Board Voltages</i></b>	<b>[Log IBV= ON]</b>	<b>AL6</b>	<b>[DIBVE]</b>
Enable logging of internal board voltage			
<b><i>(POS. 10.18) Data logger Electrodes DC Voltages Enable</i></b>	<b>[Log EDC= ON]</b>	<b>AL6</b>	<b>[DEDVE]</b>
Enable logging of electrodes DC voltage			
<b><i>(POS. 10.19) Data logger Electrodes AC voltages Enable</i></b>	<b>[Log AEC= ON]</b>	<b>AL6</b>	<b>[DEAVE]</b>
Enable logging of electrodes AC voltage			
<b><i>(POS. 10.20) Data logger Electrodes Source Impedance Enable</i></b>	<b>[Log EIZ= ON]</b>	<b>AL6</b>	<b>[DESIE]</b>
Enable logging of electrodes impedance			
<b><i>(POS. 10.21) Data logger Sensor Coils Values Enable</i></b>	<b>[Log SCV= ON]</b>	<b>AL6</b>	<b>[DSCVE]</b>
Enable logging of sensor coils value			

## MENU 10 - DATA LOGGER: ONLY MCP FUNCTIONS

<b><i>LoG All Information Enable</i></b>	<b>[MCP ONLY]</b>	<b>AL6</b>	<b>[LGAIE]</b>
Log all events information. This function save in the event file all MCP commands.			

## USING DATA LOGGER BY MCP INTERFACE

Data are stored on micro SD card; the organization is based on “tree-structure”: the system create a daily folder where it save events and data logger . The data can be downloaded by MCP interface.

### MCP Interface

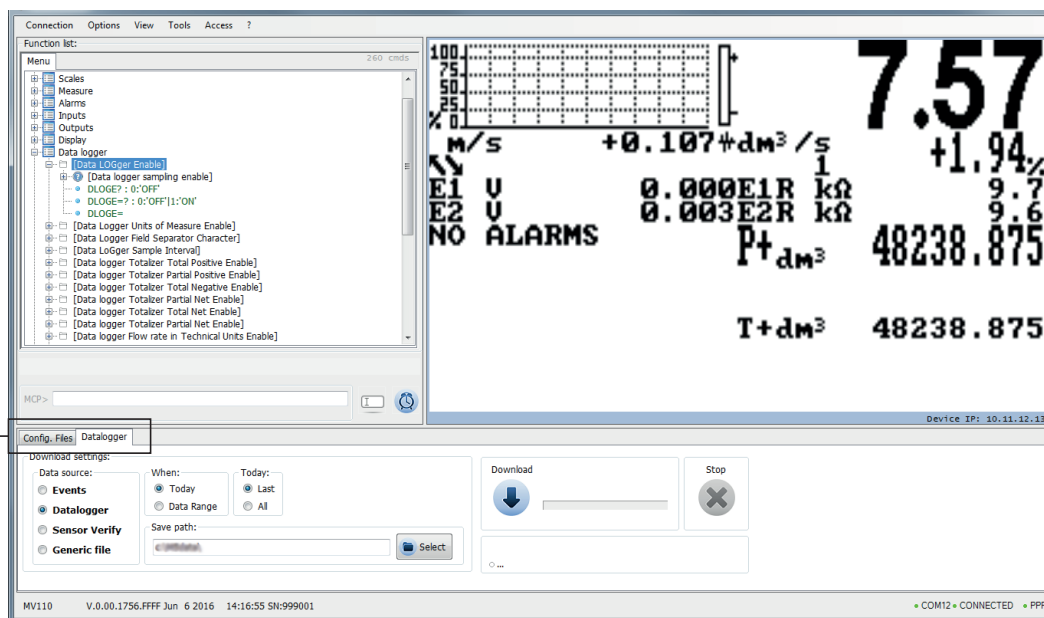

Click tab-control data logger to view files.

The sampling data backup depends on the value set by the POS function 10.4 page 25.

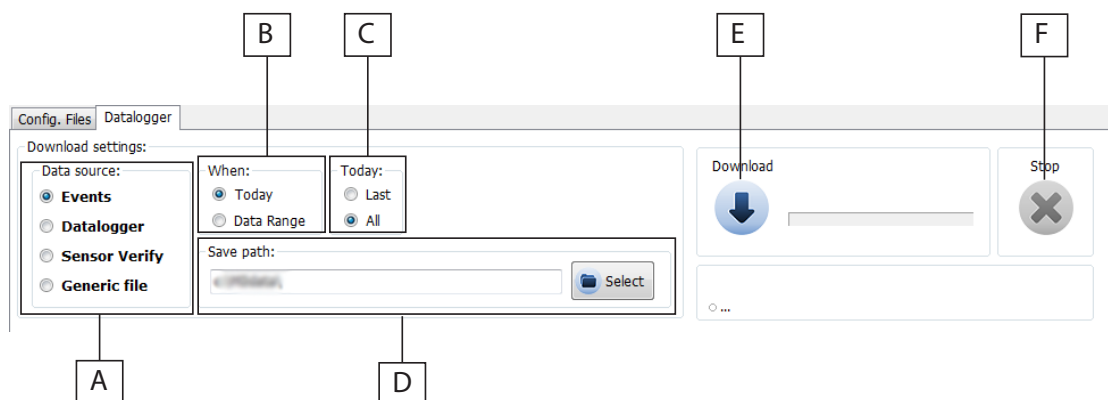

**A=Data source**

**Events:** Save the file system events (Example F-RAM hardware data [WORKING AREA] [SUCCESSFULLY LOADED])

**Data logger:** Save files of the enabled data logger function.

**Sensor Verify:** data logged by BIV function

**Generic file:**

**B=When**

Today; It indicates the download file for the current day

Data range; this option allows you to select the date range for download.

### C=Today

Last; this option allows to download the latest files, recorded after the last download  
 All; this option allows the download of all the current day of the file

### D=Save path:

This option allows you to save files to the folder on your PC

### E=Download:

Button to start the download process

### F=Stop:

Button to stop the download process

### Example: Download Events

To download all the events of the current day in a specific folder, set the below parameters as follows:  
**Data source:** Events  
**When:** Today  
**Today:** All  
**Save path:** C: / .....  
 The parameters are set then click the Download button.

Once the download is completed, a window containing the list of today's events appears. The file is saved in the specified folder in .txt format .

### Example: Download Data Logger

**Note:** it is recommended the date synchronization between converter and PC to perform correctly the events and logger reading operations.

To download all the data of the current day in a specific folder, set the below parameters as follows:  
**Data source:** DATALOGGER  
**When:** Today  
**Today:** All  
**Save path:** C: / .....  
 The parameters are set then click the Download button.

View downloaded files setting download data logger.

Note: The fields are in a fixed position, regardless if the above fields are active or not. The disabled fields are empty (delimited by the separator but without data).

Visualization of downloaded file. Access Level 2 (diagnostic level) is required in order to download this type of file.

A	N°RECORD n° n° n°	<b>N°Record:</b> View progressively the number of registered records.
B	DATE dd/mm/yy dd/mm/yy dd/mm/yy	<b>Date:</b> The recording date viewing for each record.
C	HOURS 00:00:00 00:00:00 00:00:00	<b>Hours:</b> Time recording viewing for each record.
D	U.M dm3 dm3 dm3	<b>Total positive totalizer value:</b> Form Fields when the send flag is active on the totalizer T+.
E	T+ 0 0 0	
F	U.M dm3 dm3 dm3	<b>Partial positive totalizer value:</b> Form Fields when the send flag is active on the totalizer P+.
G	P+ 0 0 0	
H	U.M dm3 dm3 dm3	<b>Total negative totalizer value:</b> Form Fields when the send flag is active on the totalizer T-.
I	T- 0 0 0	
J	U.M dm3 dm3 dm3	<b>Partial negative totalizer value:</b> Form Fields when the send flag is active on the totalizer P-.
K	P- 0 0 0	
L	U.M dm3 dm3 dm3	<b>Total net totalizer value:</b> Form Fields when the send flag is active on the totalizer TN.
M	TN 0 0 0	
N	U.M dm3 dm3 dm3	<b>Partial net totalizer value:</b> Form Fields when the send flag is active on the totalizer PN
O	PN 0 0 0	
P	U.M dm3/s dm3/s dm3/s	<b>Flow rate:</b> Form Fields present when the send flag is on the flow in units of measurement.
Q	F. RATE 0 0 0	
R	Value % % %	<b>Flow rate %:</b> value of the flow expressed in percent of the full scale.
S	FRATE % 0 0 0	Fields present when the percentage flow send flag is active.
T	ALARMS AL AL AL	<b>N° active alarms:</b> form fields present when the flag of alarm recording is active (only n° of present total alarms)
U	N° 0 0 0	
V	U.M mA mA mA	<b>Loss of current measured during insulation test:</b> available value when recording the sensor test data is active.
W	CPTI 0 0 0	
X	U.M ms ms ms	
Y	TRISEA 0 0 0	<b>Time rise A:</b> Available value when recording the sensor test data is active.
Z	U.M ms ms ms	
AA	TRISEB 0 0 0	<b>Time rise B:</b> Available value when recording the sensor test data is active.
AB	ERROR ERR ERR ERR	<b>Sensor test error code:</b> Available value when recording the sensor test data is active.
AC	N° 0 0 0	
AD	U.M V V V	<b>Voltage measured on electrode E1:</b> Form fields when is active the recording of data on the input voltage (diagnostic value).
AE	E1V 0 0 0	
AF	U.M V V V	<b>Voltage measured on electrode E2:</b> Form fields when is active the recording of data on the input voltage (diagnostic value).
AG	E2V 0.023 0.023 0.023	

AH	U,M	V	V	V	<b>Differential voltage between the two electrodes <math>VD=E1-E2</math>:</b>
AI	Value	0	0	0	Form fields when is active the recording of data on the input voltage (diagnostic value)
AJ	U,M	V	V	V	<b>Common mode voltage in the electrodes <math>VC=E1+E2/2</math>:</b>
AK	Value	0	0	0	Form fields when is active the recording of data on the input voltage (diagnostic value).
AL	U,M	V	V	V	<b>Noise at low frequency measured on the electrodes:</b>
AM	Value	0	0	0	Form fields when is active the recording of data on the input signal noise levels (diagnostic value).
AN	U,M	V	V	V	<b>Differential low frequency noise measured on the electrodes:</b>
AO	Value	0	0	0	Form fields when is active the recording of data on the input signal noise levels (diagnostic values).
AP	U,M	mV	mV	mV	<b>Low-frequency noise measured input ADC:</b>
AQ	Value	0	0	0	Form fields when is active the recording of data on the input signal noise levels (diagnostic values).
AR	U,M	mV	mV	mV	<b>High frequency noise measured input ADC:</b>
AS	Value	0	0	0	Form fields when is active the recording of data on the input signal noise levels (diagnostic values).
AT	U,M	kohm	kohm	kohm	<b>Measured equivalent resistance on the electrode 1:</b>
AU	E,IR	0	0	0	Form fields when is active the recording of data on the electrode resistance measurements (diagnostic values).
AV	U,M	kohm	kohm	kohm	<b>Measured equivalent resistance on the electrode 2:</b>
AW	E,IR	0	0	0	Form fields when is active the recording of data on the electrode resistance measurements (diagnostic values).
AX	U,M	mA	mA	mA	<b>Coils excitation current:</b>
AY	EXC.CURR.	0	0	0	Form fields when is active the recording of data related to the sensor excitation circuit measures (diagnostic value)
AZ	U,M	ohm	ohm	ohm	<b>Measured resistance of the excitation circuit (coil + cable):</b>
BA	R,COILS	0	0	0	Form fields when is active the recording of data relative to the sensor excitation circuit measures (diagnostic values).
BB	U,M	C°	C°	C°	<b>Temperature measured on the sensor coils (indirect measurement):</b> Form fields when the data transmission flag is active relative to the sensor excitation circuit measures (diagnostic values).
BC	T,COILS	0	0	0	
BD	U,M	C°	C°	C°	<b>Temperature T1 (sheet sensor 1):</b> Form fields when the data transmission flag on board the internal temperature measurement is active (diagnostic values).
BE	T1	0	0	0	
BF	U,M	C°	C°	C°	<b>Temperature T2 (sheet sensor 2):</b> Form fields when the data transmission flag on board the internal temperature measurement is active (diagnostic values).
BG	T2	0	0	0	
BH	U,M	C°	C°	C°	<b>CPU temperature:</b> Form fields when the data on the card's internal power supply voltage measurements flag is ON (diagnostic value).
BI	T,CPU	0	0	0	
BJ	U,M	V	V	V	<b>Primary power supply of CPU:</b> Form fields when the data on the card's internal power supply voltage measurements flag is ON (diagnostic value).
BK	V,CPU	0	0	0	
BL	U,M	V	V	V	<b>Positive supply voltage of analog circuits:</b> Form fields when the data on the card's internal power supply voltage measurements flag is ON (diagnostic values).
BM	Value	0	0	0	
BN	U,M	V	V	V	<b>Negative supply voltage of the analog circuits:</b> Form fields when the data on the card's internal power supply voltage measurements flag is ON (diagnostic values).
BO	Value	0	0	0	
BQ	BP	/	/	/	<b>Not available value</b>
BR	U,M	V	V	V	<b>Unit of measure and Voltage value of rechargeable battery.</b> Form fields when the data on the card's internal power supply voltage measurements flag is ON (diagnostic values).
BS	BATT	0	0	0	
BT	Value	%	%	%	<b>% Battery charge:</b> Form fields when the data on the card's internal power supply voltage measurements flag is ON (diagnostic values).
BU	BATT %	0	0	0	
BV	HEX 0x8A97 0xD1D8 0x3754				<b>Checksum</b>

The manufacturer guarantees only English text available on our web site www.isomag.com

### Example: Sensor Verify

The function “Sensor Verify” creates the “STESTLOG.CSV” file, according to the following conditions:

- 1) Activate the SDC / RTC option in group “HW Config” (by factory see the order code)
- 2) Activate the “BIV” in the group “PRODUCT CODE” (by factory see the order code)
- 3) Activate the “Sens.verify” function in the “Sensor” menu

Activated such conditions, the converter will perform every hour a measure of sensor’s parameters and record a line of the file “STESTLOG.CSV”; it is possible even a manual verification by the command “sens.verify” on the menu “Diagnostic” or through the MCP command “SVERC”.

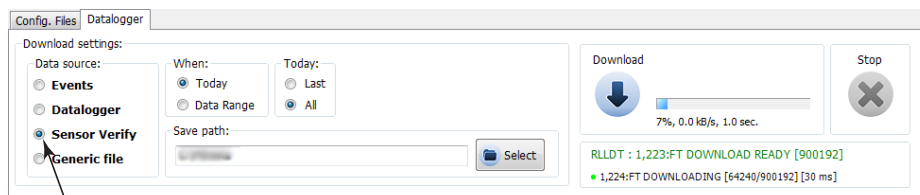

To download all the sensor measure for the current day in a specific folder, set the below parameters as follows:

**Data source:** Sensor Verify

**When:** Today

**Today:** All

**Save path:** C: / .....

The parameters are set then click the Download button.

### Example: Generic File

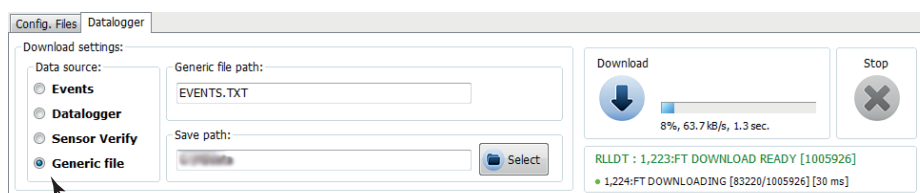

This function allows to select a file in the SD memory and download it. In the “Generic file path” specify the file name contained in the SD and indicate “Save path” where to save the file. Set these values to proceed with the download by clicking the “download”.

## MENU 11 - FUNCTION

The following functions are activated by first pressing the “ENTER” and then the “ESC” when the screen appears “confirm” to start the function.

<b><i>(POS. 11.1) Volume Totalizer Total Positive Reset</i></b>	<b>[T+ RESET= ON]</b>	<b>AL3</b>	<b>[VTTPR]</b>
---	-----------------------	------------	----------------

Reset total direct totalizer for direct flow rate (+)

<b><i>(POS. 11.2) Volume Totalizer Partial Positive Reset</i></b>	<b>[P+ RESET= ON]</b>	<b>AL3</b>	<b>[VTPPR]</b>
---	-----------------------	------------	----------------

Reset total partial totalizer for direct flow rate (+)

<b><i>(POS. 11.3) Volume Totalizer Total Negative Reset</i></b>	<b>[T- RESET= ON]</b>	<b>AL3</b>	<b>[VTTNR]</b>
---	-----------------------	------------	----------------

Reset total reverse totalizer for direct flow rate (-)

<b><i>(POS. 11.4) Volume Totalizer Partial Negative Reset</i></b>	<b>[P- RESET= ON]</b>	<b>AL3</b>	<b>[VTPNR]</b>
---	-----------------------	------------	----------------

Reset partial reverse totalizer for direct flow rate (-)

<b><i>(POS. 11.5) Load Factory Default Sensor Data</i></b>	<b>[Load sens.f.def= ON]</b>	<b>AL3</b>	<b>[LFSDS]</b>
--	------------------------------	------------	----------------

This function resets the parameters of the sensor factory default. To Load the saved files see function (11.7).

<b><i>(POS. 11.6) Load Factory Default Converter Data</i></b>	<b>[Load conv.f.def= ON]</b>	<b>AL3</b>	<b>[LFDSD]</b>
---	------------------------------	------------	----------------

This function resets the parameters of the converter factory default. o Load the saved files see function (11.8).

<b><i>(POS. 11.7) Save Factory Default Sensor Data</i></b>	<b>[Save sens.f.def= ON]</b>	<b>AL6</b>	<b>[SFSDS]</b>
--	------------------------------	------------	----------------

This function save the parameters of the sensor factory default.

<b><i>(POS. 11.8) Save Factory Default Converter Data</i></b>	<b>[Save conv.f.def= ON]</b>	<b>AL6</b>	<b>[SFDCD]</b>
---	------------------------------	------------	----------------

This function loads the data from a converter to another.

<b><i>(POS. 11.9) CALibration Immediate Command</i></b>	<b>[Calibration]</b>	<b>AL5</b>	<b>[CALIC]</b>
---	----------------------	------------	----------------

Perform manually a board’s calibration. Press Enter and the message “EXECUTE?” will be visualized on the display then press long the key Enter to proceed. Press any other key to delete the operation.

If the sensor table is valid, the calibration is performed also when one of the following parameter has been change:

- SENSOR DIAMETER -> Menu Sensor1
- SENSOR MODEL -> Menu Sensor1
- Exc. CURRENT -> Menu Sensor1
- S. Freq. -> Menu Sensor1

To check the calibration status, active or inactive, type the command MCP Calic? and check as follows:

- CALIC = 1 calibration in progress
- CALIC = 0 calibration terminated

## MENU 11 - Function: ONLY MCP FUNCTIONS

<b><i>Sensor ReFERENCE Data Save</i></b>	<b>[MCP ONLY]</b>	<b>AL4</b>	<b>[SRFDS]</b>
--	-------------------	------------	----------------

Save conv.f.def= ON. "meter data" page 77

## MENU 12 - DIAGNOSTIC

**(POS. 12.1) AutoTeSt Immediate Command** [Self Test] **AL3** [ATSIC]

Meter auto-test function. This function stops the normal functions of the meter and performs a complete test cycle on the measure input circuits and on the excitation generator. To activate this function, after select it, push key Enter, at the question: "CONFIRM EXEC.?" Long Push the same key to start auto-test, or any other key for delete operation. At the end of operation the converter will revert to one of the initial visualization pages. This function is automatically performed when switching on the device. This function restarts the converter.

**(POS. 12.2) Test display** [ Test display ] **AL1 NO MCP COMMAND**

This function allows to do a physical test the graphic display. During this operation, 4 sequences are displayed to test the correct functioning of the device.

**(POS. 12.3) Sensor VERify Command** [ Sens. verify ] **AL3** [SVERC]

This function perform a manual sensor verification ( if BIV is active)

**(POS. 12.4) Measure SIMulation ENable** [Flow sim=ON] **AL3** [MSIEN]

Flow rate simulation enabling. With this function it is possible to generate an internal signal that simulates the flow rate, allowing the outputs and all the connected instruments test.

After enabling it, a '▲▼' appears in the top left of the screen and the flow rate simulation can be:

- set:** by pushing the key Enter from one of visualization pages, to set the required % flow rate (FI.rate=%) and the same key to confirm the value;
- finished:** by pushing the key Enter from visualization pages and then by long pushing the same key.

**(POS. 12.5) Diagnostic Measure VaLueS** [Display measures] **AL5** [DMVLS]

This Function shows the values of the various internal parameters as listed below:

```

UCPU:U          5.01  LFN_COM:U      0.0000
UPS:U           5.41  LFN_DIF:U      0.0000
UUSB:U          4.53  LFN_ADC:MU     0.0000
+AUCC:U        +10.1  LFN_ADC:MU     0.0001
-AUCC:U         -9.9  MEAS_NB:      0.0000
UBATT:U         0.000  CAL_I:MU       16.5033
IBATT:A        -0.000  CAL_U:MU      320.7788
VIN1:U         -8.071  CAL_G:MU      -0.16222
VIN2:U         -8.065  CAL_O:MA      -0.05555
VIN_C:U        -8.068  CAL_C:MA      1.0000000
VIN_D:U        -0.006  CAL_R0:       1.0000000
C_C:MA         25.00  CAL_R1:       1.0000000
C_U:U          5.0   CAL_R2:       1.0000000
C_VPK:U        5.5   CAL_R3:       1.0000000
C_R:Ω          201.9  SVS_F:MHz     50.0512
C_PWR:W        0.126  CURR_K:       0.00000
C_T:°C         -.-   PROC1:%%      46.4
C_RI:ms        0.00  PROC2:%%      7.4
C_LK:MA        0.000  PROC3:%%      2.2
C_ST:          1     PROC4:%%      1.2
S_UER_RSLT:    0000  PROC5:%%      16.4
E1R:kΩ         0.0   CPU_T:°C      +33.12
E2R:kΩ         0.0
    
```

**(POS. 12.6) Diagnostic Communication VaLueS** [ Disp. comm. vars ] **AL5** [DCVLS]

Create a list of diagnostic values on the instrument communication.

```

PPP link status ——— PPP_STATUS: NETW E_IP_HDR5: 3
MCPI socket status ——— MCPI_S: ESTABLISH E_IP_HDR6: 0
RxCNT: 1477149 E_IP_HDR7: 0
TxCNT: 6515456 E_IP_HDR8: 0
E_SR_LINK: 0 E_IP_HDR9: 0
E_PAKTLEN: 0 E_ICPHDR1: 0
E_NETLAYR: 0 E_ICPHDR2: 0
E_TSPLAYR: 0 E_UDPHDR1: 0
E_ARPHDR1: 0 E_UDPHDR2: 0
E_ARPHDR2: 0 E_UDPHDR3: 92
E_IP_HDR1: 0 E_ICMPHDR: 0
E_IP_HDR2: 0
E_IP_HDR3: 0
E_IP_HDR4: 0
    
```

Following are the states for the PPP link and MCPI to connect the device.

**PPP link status:**

- “UNDT” = undetermined
- “DEAD” = dead, link down, persistent condition
- “LCP” = LCP phase, transition condition
- “AUTH” = Authentication phase, transition condition
- “IPCP” = IP and DNS addressess assign phase, transition condition
- “NETW” = network established (normal persistent condition when the link is UP)
- “TERM” = link termination request, transition condition

**MCPI link status:**

- “CLOSED” = socket closed
- “ACCEPT” = socket awaiting for new connection
- “ESTABLISH” = link established
- “CLS\_WAIT” = waiting for closure
- “LAST\_ACK” = lask ACK sent
- “FIN\_WAIT” = (see TCP/IP RFC documentation)
- “TIME\_WAIT” = (see TCP/IP RFC documentation)

The manufacturer guarantees only English text available on our web site www.isom.com

**(POS. 12.7) OscilloSCOPE function** [ Display graphs ] **AL5 NO MCP COMMAND**

This function displays graphs of input Z, C. current, C. Volt, C.Load, Input 1, Input 2, Input1-Input 2, Analog to Digital Converter.

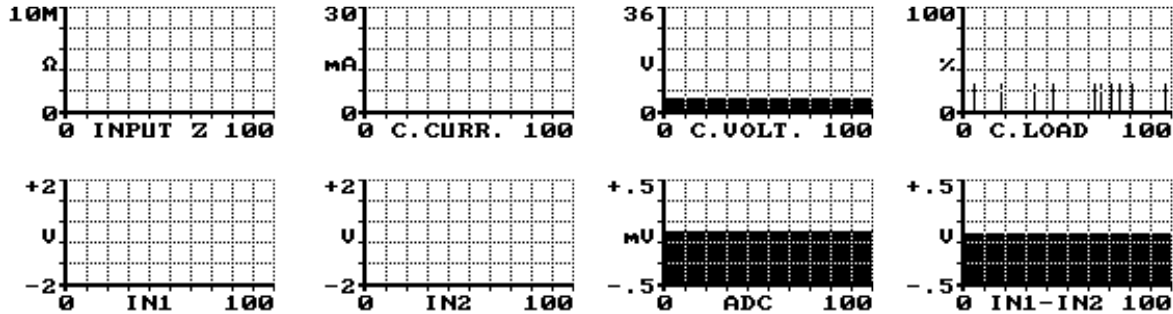

**(POS. 12.8) Generic sensor set** [ Gen.sens. set ] **AL5 NO MCP COMMAND**

Automatic finding of a parameter set for a generic sensor.

**(POS. 12.9) SD memory STATus** [SD card info] **AL0 [SDSTA]**

This function shows the status of the SD card as shown in the following figure.

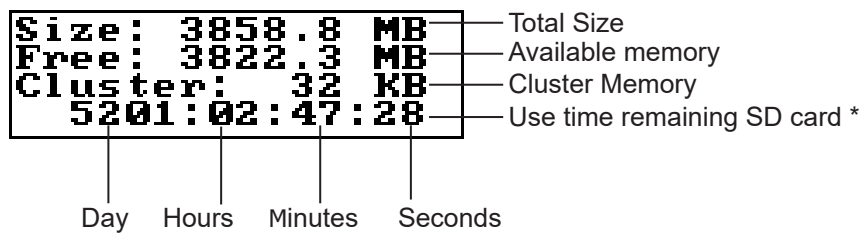

The statistical calculation is performed every time the command SDSTA is invoked. The statistical data are updated AUTOMATICALLY every day (24 hours) or manually each time the function is called to display or send the SDSTA command. However, given that for the detection is necessary a minimum of one hour, the data will not be recomputed before this time interval.

<pre> Size: 3858.8 MB Free: 3822.3 MB Cluster: 32 KB 5201:02:47:28                 </pre>	<pre> Size: 3858.8 MB Free: 3822.3 MB Cluster: 32 KB 0158:21:23:13                 </pre>
---	---

minimum time of 1 hour for the new data update

The SD card must be replaced only by the service. The use of commercial cards could disable some functionality of the instrument.

**(POS. 12.10) Model and Software Version** [Firmware info] *ALO* [MODSV]

Firmware info version/revision

```

MV110
U.0.00.1403.FFFF
Apr 22 2016
12:35:47
    
```

**(POS. 12.11) Serial Number** [ S/N= xxxxxx ] *ALO* [SRNUM?]

View Board serial number. (read only)

**(POS. 12.12) Total Working Time** [ WT= xxxx: xx: xx: xx ] *ALO* [TWKTM?]

View Total working time instrument. (read only)

The manufacturer guarantees only English text available on our web site www.isoil.com

## MENU 13 - SYSTEM

<b>(POS. 13.1) DaYlight Saving Time Enable</b>	<b>[Dayl. Saving= ON]</b>	<b>AL2</b>	<b>[DYSTE]</b>
--	---------------------------	------------	----------------

Daylight saving time change.

<b>(POS. 13.2) Time ZONE</b>	<b>[Time zone=h+xx.xx]</b>	<b>AL2</b>	<b>[TZONE]</b>
------------------------------	----------------------------	------------	----------------

Set time for geographic area

<b>(POS. 13.3) Date and TIME</b>	<b>[xxxx/xx/xx-xx:xx]</b>	<b>AL2</b>	<b>[DTIME]</b>
----------------------------------	---------------------------	------------	----------------

Set to system date and time

<b>(POS. 13.4-5-6-7-8-9) Level n° Access CoDe</b>	<b>[Ln xxxxxxxx]</b>	<b>---</b>	<b>[L1ACD]-&gt; [L6ACD]</b>
---	----------------------	------------	-----------------------------

This function enables or disables, for each access level code, the main menu functions.

Each level unlocks the functionality of the lower level. (Function 1.19 see page 34 )

L1 code= \*\*\*\*\* Access level value code 1    L4 code= \*\*\*\*\* Access level value code 4

L2 code= \*\*\*\*\* Access level value code 2    L5 code= \*\*\*\*\* Access level value code 5

L3 code= \*\*\*\*\* Access level value code 3    L6 code= \*\*\*\*\* Access level value code 6

<b>(POS. 13.10) ReStricted Access Rule Enable</b>	<b>[Restr. access= ON]</b>	<b>AL6</b>	<b>[RSARE]</b>
---	----------------------------	------------	----------------

Enable Or disable access level code. If active displays only the functions related to the level entered access.

### IP ADDRESS SETTING (13.11-12-13)

<b>(POS. 13.11) Device IP address</b>	<b>[XXX.XXX.XXX.XXX]</b>	<b>AL3</b>	<b>[DIPAD]</b>
---------------------------------------	--------------------------	------------	----------------

Device IP network address

<b>(POS. 13.12) Client IP address</b>	<b>[XXX.XXX.XXX.XXX]</b>	<b>AL3</b>	<b>[CIPAD]</b>
---------------------------------------	--------------------------	------------	----------------

Client IP network address

<b>(POS. 13.13) Network mask</b>	<b>[XXX.XXX.XXX.XXX]</b>	<b>AL3</b>	<b>[NETMS]</b>
----------------------------------	--------------------------	------------	----------------

Network mask.

Caution: Changes to the functions of the points 13.11-13.12-13.13 are enabled after the drive device restart (see function 12.1 Self test for restart converter).

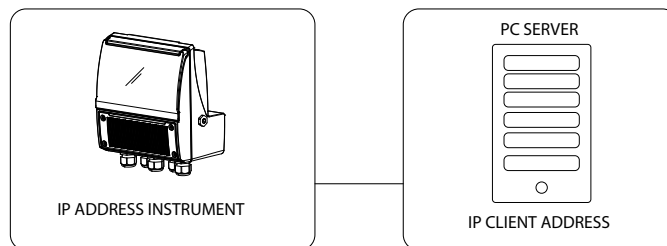

<b>(POS. 13.14) CoeFFicient KT</b>	<b>[KF=X.XXXXXX]</b>	<b>AL6</b>	<b>[CFFKT]</b>
------------------------------------	----------------------	------------	----------------

Gain correction coefficient (calculated automatically)

<b>(POS. 13.15) CoeFFicient KS</b>	<b>[KF=X.XXXXXX]</b>	<b>AL5</b>	<b>[CFFKS]</b>
------------------------------------	----------------------	------------	----------------

Correction coefficient constant instrumental

**(POS. 13.16) Coefficient KR** [KR=X.XXXXX] **AL5** [CFFKR]  
 Correction coefficient constant instrumental

**DIGITAL ANALOG CONVERTER (Correction Parameters)(13.17-18-19-20)**

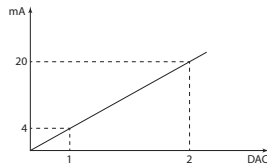

The diagram shows how the DAC4-20mA parameters are setup. The DAC1 value corresponds to 4 mA corresponding to a zero flow rate, while the value of 20mA corresponds to a 100% of the flow rate.

**(POS. 13.17) Current output 1 Calibration Point 1** [DAC1 4mA =XXXXX] **AL5** [C1CP1]  
 DAC1 out 4mA calibration point. (current output1 calibration point 1)

**(POS. 13.18) Current output 1 Calibration Point 2** [DAC1 20mA=XXXXX] **AL5** [C1CP2]  
 DAC1 out 20mA calibration point. (current output1 calibration point 2)

**(POS. 13.19) Current output 2 Calibration Point 1** [DAC1 20mA=XXXXX] **AL5** [C2CP1]  
 DAC2 out 4mA calibration point. (current output2 calibration point 1)

**(POS. 13.20) Current output 2 Calibration Point 2** [DAC2 20mA=XXXXX] **AL5** [C2CP2]  
 DAC2 out 20mA calibration point (current output2 calibration point 2)

**(POS. 13.21) Stand-BY** [STAND-BY] **AL3** [SSTBY]  
 Enable the converter standby state. It is enable by selecting chargeable battery in hw confing.

**(POS. 13.22) FirmWare UPDate** [FW update] **AL4** [FWUPD]  
 Enable firmware update. The firmware can be upload to the SD card (name.file).  
 MCP interface is activated by the command FWUPD = name.file

The manufacturer guarantees only English text available on our web site www.isoil.com

## MENU 13 - SYSTEM: only MCP functions

<b>Unique Identity KEY</b>	[MCP ONLY]	AL0	[UIKEY]
Device Unique Identity key			
<b>HardWare SET</b>	[MCP ONLY]	AL0	[HWSET]
Device hardware configuration			
<b>HardWare CODE</b>	[MCP ONLY]	AL0	[HWCOD]
Device hardware code			
<b>CALibration eXecution status Memory</b>	[MCP ONLY]	AL6	[CALXM]
Calibration Execution status Memory. This function checks the instrument's internal calibration status. CALXM=1 instrument calibrated correctly CALXM=0 Invalid calibration / Calibration not completed (invalid calibration (if the function is zero, start the calibration function, MCP CALIC command).			
<b>RTC Adjustment Coefficient</b>	[MCP ONLY]	AL2	[RTCAC]
RTC is used to set a correction factor for the internal clock. For setting the correction date and time with MCP press 			
<b>Function CODE Selection</b>	[MCP ONLY]	AL0	[FCODS]
Select the function code			
<b>FuNction Enable State Selection</b>	[MCP ONLY]	AL6	[FNESS]
Select the enable state of function			
<b>All FuNctions State Selection</b>	[MCP ONLY]	AL6	[AFNSS]
Select enable state of ALL function			
<b>Quick Start FuNction Selection</b>	[MCP ONLY]	AL6	[QSFNS]
Select function for quick start menu			
<b>Quick Start All Functions Selection</b>	[MCP ONLY]	AL6	[QSAFS]
Select ALL function converter for quick start menu.			
<b>Quick start function Status LiST</b>	[MCP ONLY]	AL6	[QSLST]
List quick start group functions			
<b>Function enable Status LiST</b>	[MCP ONLY]	AL6	[FSLST]
List enable status of functions			

<b>Access CODE</b>	[MCP ONLY]	ALO	[ACODE]
--------------------	------------	-----	---------

Input the right access code

Example set quick start menu function for mcp.

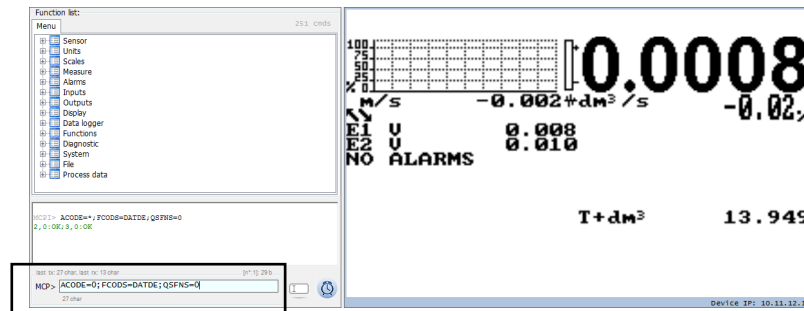

ACODE=0; FCODS=[MCP COMMAND]; QSFNS=1

Access Code

INSERT MCP Command of the function to be activated in the QS menu.

Quick Start Function Selection

<b>LINK Terminate</b>	[MCP ONLY]	ALO	[LTERM]
-----------------------	------------	-----	---------

Terminate the PPP data link

<b>MCPI session QUIT</b>	[MCP ONLY]	ALO	[MQUIT]
--------------------------	------------	-----	---------

Quit the MCPI connection

<b>Functions LIST</b>	[MCP ONLY]	ALO	[FLIST]
-----------------------	------------	-----	---------

View list of all available converter functions.

<b>Functions LIST Compact</b>	[MCP ONLY]	ALO	[FLISC]
-------------------------------	------------	-----	---------

View compact list of all available converter functions.

<b>Functions Menu SElection</b>	[MCP ONLY]	ALO	[FMSEL]
---------------------------------	------------	-----	---------

Select menu for functions list

<b>Configuration LiST</b>	[MCP ONLY]	ALO	[CFLST]
---------------------------	------------	-----	---------

Configuration parameter list. The list with the status / values of the converter parameter.

<b>Volume Totalizer Total Positive Set</b>	[MCP ONLY]	AL4	[VTTPS]
--	------------	-----	---------

Totalizer T+ value set

<b>Volume Totalizer Partial Positive Set</b>	[MCP ONLY]	AL4	[VTPPS]
--	------------	-----	---------

Totalizer P+ value set

The manufacturer guarantees only English text available on our web site www.isoil.com

<b><i>Volume Totalizer Total Negative Set</i></b>	<b>[MCP ONLY]</b>	<b>AL4</b>	<b>[VTNS]</b>
Totalizer T- value set			
<b><i>Volume Totalizer Partial Negative Set</i></b>	<b>[MCP ONLY]</b>	<b>AL4</b>	<b>[VTPNS]</b>
Totalizer P- value set			
<b><i>Volume Total Positive Overflow Set</i></b>	<b>[MCP ONLY]</b>	<b>AL4</b>	<b>[VTPOS]</b>
Totalizer T+ overflow value set			
<b><i>Volume Partial Positive Overflow Set</i></b>	<b>[MCP ONLY]</b>	<b>AL4</b>	<b>[VPPOS]</b>
Totalizer P+ overflow value set			
<b><i>Volume Total Negative Overflow Set</i></b>	<b>[MCP ONLY]</b>	<b>AL4</b>	<b>[VTNOS]</b>
Totalizer T- overflow value set			
<b><i>Volume Partial Negative Overflow Set</i></b>	<b>[MCP ONLY]</b>	<b>AL4</b>	<b>[VPNOS]</b>
Totalizer P- overflow value set			
<b><i>CPU MaX.recorded temperature</i></b>	<b>[MCP ONLY]</b>	<b>AL6</b>	<b>[CPUMX]</b>
CPU max.recorded temperature			
<b><i>CPU MiN.recorded temperature</i></b>	<b>[MCP ONLY]</b>	<b>AL6</b>	<b>[CPUMN]</b>
CPU min.recorded temperature			
<b><i>Board T1 MaX.recorded temperature</i></b>	<b>[MCP ONLY]</b>	<b>AL6</b>	<b>[BT1MX]</b>
T1 max.recorded temperature			
<b><i>Board T1 MiN.recorded temperature</i></b>	<b>[MCP ONLY]</b>	<b>AL6</b>	<b>[BT1MN]</b>
T1 min.recorded temperature			
<b><i>Board T2 MaX.recorded temperature</i></b>	<b>[MCP ONLY]</b>	<b>AL6</b>	<b>[BT2MX]</b>
T2 max.recorded temperature			
<b><i>Board T2 MiN.recorded temperature</i></b>	<b>[MCP ONLY]</b>	<b>AL6</b>	<b>[BT2MN]</b>
T2 min.recorded temperature			
<b><i>Calibration Offset Register 0</i></b>	<b>[MCP ONLY]</b>	<b>AL6</b>	<b>[COFR0]</b>
Calibration offset register 0			
<b><i>Calibration Offset Register 1</i></b>	<b>[MCP ONLY]</b>	<b>AL6</b>	<b>[COFR1]</b>
Calibration offset register 1			

<b>Calibration GAin Register 0</b>	<b>[MCP ONLY]</b>	<b>AL6</b>	<b>[CGAR0]</b>
Calibration gain register 0			
<b>Calibration GAin Register 1</b>	<b>[MCP ONLY]</b>	<b>AL6</b>	<b>[CGAR1]</b>
Calibration gain register 1			
<b>Calibration GAin Register 2</b>	<b>[MCP ONLY]</b>	<b>AL6</b>	<b>[CGAR2]</b>
Calibration gain register 2			
<b>Calibration GAin Register 3</b>	<b>[MCP ONLY]</b>	<b>AL6</b>	<b>[CGAR3]</b>
Calibration gain register 3			
<b>Calibration GAin Register C</b>	<b>[MCP ONLY]</b>	<b>AL6</b>	<b>[CGARC]</b>
Calibration gain register C			

## MENU 14 - FILE (ONLY MCP)

<b><i>File Transfer ABoRt</i></b>	[MCP ONLY]	AL2	[FTABR]
Abort the current File Transfer			
<b><i>File Transfer STAtE</i></b>	[MCP ONLY]	AL0	[FTSTA]
Show the File Transfer state			
<b><i>Read Last EVenTs</i></b>	[MCP ONLY]	AL2	[RLEVT]
Read the latest system events			
<b><i>Read All EVenTs</i></b>	[MCP ONLY]	AL2	[RAEVT]
Read all current system events			
<b><i>Read Last Logged DaTa</i></b>	[MCP ONLY]	AL2	[RLLDT]
Read the latest logged data			
<b><i>Read All Logged DaTa</i></b>	[MCP ONLY]	AL2	[RALDT]
Read all current logged data			
<b><i>Read Last Sensor Verify Data</i></b>	[MCP ONLY]	AL2	[RLSVD]
Read the latest sensor ver. data			
<b><i>Read All Sensor Verify Data</i></b>	[MCP ONLY]	AL2	[RASVD]
Read all sensor verify data			
<b><i>File SEND</i></b>	[MCP ONLY]	AL2	[FSEND]
Set file name for read operation			
<b><i>File ReCeIVE</i></b>	[MCP ONLY]	AL5	[FRCVE]
Set file name for write operation			
<b><i>File ReCeive APpend mode</i></b>	[MCP ONLY]	AL5	[FRCAP]
Set file name for write-append			
<b><i>File OFFSet position</i></b>	[MCP ONLY]	AL2	[FOFFS]
Set file offset position			
<b><i>ConFiGuration file WRite</i></b>	[MCP ONLY]	AL2	[CFGWR]
Save the configuration to a file			
<b><i>ConFiGuration file ReaD</i></b>	[MCP ONLY]	AL2	[CFGRD]
Read the configuration from file			

<b><i>FuNction list file WRite</i></b>	[MCP ONLY]	<b><i>AL2</i></b>	[FNCWR]
Save the functions list to file			
<b><i>Function Enable Status WRite</i></b>	[MCP ONLY]	<b><i>AL6</i></b>	[FESWR]
Save function enable status to file			
<b><i>Quick Start function Status WRite</i></b>	[MCP ONLY]	<b><i>AL6</i></b>	[QSSWR]
Save quick start function enable			

## MENU 15 - PROCESS DATA (ONLY MCP)

<b><i>OUTput 1 Set</i></b>	[MCP ONLY]	<b><i>AL0</i></b>	[OUT1S]
Set value for digital output 1			
<b><i>OUTput 2 Set</i></b>	[MCP ONLY]	<b><i>AL0</i></b>	[OUT2S]
Set value for digital output 2			
<b><i>Digital INput 1 Status</i></b>	[MCP ONLY]	<b><i>AL0</i></b>	[DIN1S]
Digital input 1 status read			
<b><i>Flow Rate Full Scale in chosen Units</i></b>	[MCP ONLY]	<b><i>AL0</i></b>	[FRFSU]
Flow rate full scale in chosen units			
<b><i>Flow Rate Scale Range Number</i></b>	[MCP ONLY]	<b><i>AL0</i></b>	[FRFSN]
Full scale active range			
<b><i>Flow Rate Value PerCentage</i></b>	[MCP ONLY]	<b><i>AL0</i></b>	[FRVPC]
Flow rate value in percentage			
<b><i>Flow Rate Value Percentage without cut-off</i></b>	[MCP ONLY]	<b><i>AL0</i></b>	[FRVPX]
Flow rate in percentage without cut-off			
<b><i>Flow Rate Value Binary without cut-off</i></b>	[MCP ONLY]	<b><i>AL0</i></b>	[FRVBX]
Flow rate in binary without cut-off			
<b><i>Flow Rate Value Technical Unit</i></b>	[MCP ONLY]	<b><i>AL0</i></b>	[FRVTU]
Flow rate value in unit of measure			
<b><i>Volume Totalizer Total Positive Value</i></b>	[MCP ONLY]	<b><i>AL0</i></b>	[VTTPV]
Totalizer T+ read value			
<b><i>Volume Totalizer Partial Positive Value</i></b>	[MCP ONLY]	<b><i>AL0</i></b>	[VTPPV]
Totalizer P+ read value			

<b><i>Volume Totalizer Total Negative Value</i></b>	<b>[MCP ONLY]</b>	<b><i>ALO</i></b>	<b>[VTTNV]</b>
Totalizer T- read value			
<b><i>Volume Totalizer Partial Negative Value</i></b>	<b>[MCP ONLY]</b>	<b><i>ALO</i></b>	<b>[VTPNV]</b>
Totalizer P- read value			
<b><i>Volume Totalizer Total Positive Overflow</i></b>	<b>[MCP ONLY]</b>	<b><i>ALO</i></b>	<b>[VTTPO]</b>
Totalizer T+ number of overflows			
<b><i>Volume Totalizer Partial Positive Overflow</i></b>	<b>[MCP ONLY]</b>	<b><i>ALO</i></b>	<b>[VTPPO]</b>
Totalizer P+ number of overflows			
<b><i>Volume Totalizer Total Negative Overflow</i></b>	<b>[MCP ONLY]</b>	<b><i>ALO</i></b>	<b>[VTTNO]</b>
Totalizer T- number of overflows			
<b><i>Volume Totalizer Partial Negative Overflow</i></b>	<b>[MCP ONLY]</b>	<b><i>ALO</i></b>	<b>[VTPNO]</b>
Totalizer P- number of overflows			
<b><i>Board TeMPeratures</i></b>	<b>[MCP ONLY]</b>	<b><i>ALO</i></b>	<b>[BTMPS]</b>
Board temperatures			
<b><i>CPU temperature</i></b>	<b>[MCP ONLY]</b>	<b><i>ALO</i></b>	<b>[CPUTP]</b>
CPU temperature			
<b><i>Sensor CoILs TeMPerature</i></b>	<b>[MCP ONLY]</b>	<b><i>ALO</i></b>	<b>[SCLTP]</b>
Sensor's coils temperature			
<b><i>LiQuid VELOCITY</i></b>	<b>[MCP ONLY]</b>	<b><i>ALO</i></b>	<b>[LQVEL]</b>
Liquid velocity			
<b><i>AVerAGe process data Samples Number</i></b>	<b>[MCP ONLY]</b>	<b><i>ALO</i></b>	<b>[AVGSN]</b>
Number of samples for averaged values			
<b><i>ALARM status</i></b>	<b>[MCP ONLY]</b>	<b><i>ALO</i></b>	<b>[ALARM]</b>
Active alarm(s) status			
<b><i>Sensor TeSt Result Code</i></b>	<b>[MCP ONLY]</b>	<b><i>ALO</i></b>	<b>[STSRC]</b>
Sensor test result code			
<b><i>Main power status</i></b>	<b>[MCP ONLY]</b>	<b><i>ALO</i></b>	<b>[MPWRS]</b>
Status of main power supply			
<b><i>INput RESistance</i></b>	<b>[MCP ONLY]</b>	<b><i>ALO</i></b>	<b>[INRES]</b>
Equivalent Input resistance			

<b><i>INput Voltages</i></b>	[MCP ONLY]	<b><i>ALO</i></b>	[INVLS]
Electrodes input voltages			
<b><i>System Battery Voltage</i></b>	[MCP ONLY]	<b><i>ALO</i></b>	[SBVLT?]
View battery voltage			
<b><i>System Battery Charge Status</i></b>	[MCP ONLY]	<b><i>ALO</i></b>	[SBCHS?]
View system battery charge status			
<b><i>Measure BUFFers</i></b>	[MCP ONLY]	<b><i>ALO</i></b>	[MBUFF]
Measure buffers data read			
<b><i>SEquence NumBer</i></b>	[MCP ONLY]	<b><i>ALO</i></b>	[SEQNB]
Sequence number			
<b><i>Sensor TaBLe Version</i></b>	[MCP ONLY]	<b><i>ALO</i></b>	[STBLV]
Sensor's table version			

## METER DATA

The "METER DATA" system allows the import of data up to level 4, included, (working and factory parameters of the card) of the converter to another device and the restoration of the data of a meter in case the electronic card needs to be replaced .

**Operation:** during normal operation the meter saves all data, including the dynamic data of the totalizers, every hour, on a specific file on the SD card. The file is incremental, so its length increases linearly over the time. Each recording is time-stamped for future use. Currently, automatic data recovery uses only the last valid recording in chronological order.

**Data reset:** The reset is done manually, after inserting the SD card taken from the meter to be replaced, on the new electronics to be used as a replacement. This operation must be done strictly with the electronics off. Once the SD card has been replaced, wait for the device to restart and connect the MCP interface via the USB connection. Then select the "Data recovery" function on the "Functions" menu and confirm. Wait for the device to restart (the time required will depend on the configuration and the presence or absence of operations with the modem, if installed).

**Consequences of restoring data on the SD card:** the new electronic card will acquire all the existing data from the old meter. The root directory of the old card will be renamed with the serial number of the new card and no existing data will be altered. The data that belonged to the new card that may have been created during the recovery (data logger or events) are stored in a root directory with the name "<new card series number> .OLD". In any case, no data will be overwritten or deleted.

**Limits of data saving and retrieval: Data recovery is possible with the following limitations:**

- The new board to be used as a replacement must have the same hardware configuration as the one to be replaced.
- If the device to be replaced is MID, the new board to be used as a replacement must already be preconfigured as MID, with the appropriate functions locked and the CRC comparison value set correctly.
- It is NOT possible to recover any passwords saved for internet connection services (email, FTP, etc.). These will need to be re-entered manually or via a separate configuration file. Restoring data does NOT involve resetting any passwords that may have been pre-configured in the new card.
- It is NOT possible to recover the passwords relating to the access levels of the instrument. Also in this case they will be re-set manually or pre-configured in the new board.
- The data relating to the hardware calibrations of the board are NOT transferred, therefore those stored in the new board remain valid.

**The following data are NOT recoverable:**

- Function parameters accessible with level 5 and 6 (typically hardware calibration data)
- Passwords and others encrypted data
- Hardware configuration parameters
- Enable status of the functions selected for the "quick-start" menu
- System function enable status

The recovered data are also saved simultaneously in the "FACTORY DEFAULTS" memory and they become the new factory standard values of the board.

## OPERATING PROCEDURE TO CHANGE THE CONVERTER BOARD



Remove the 4 screws (see "MV110 construction (ALUMINIUM AND PA6 VERSIONS)" page14) to remove the main housing. Attention of any electrical cables.

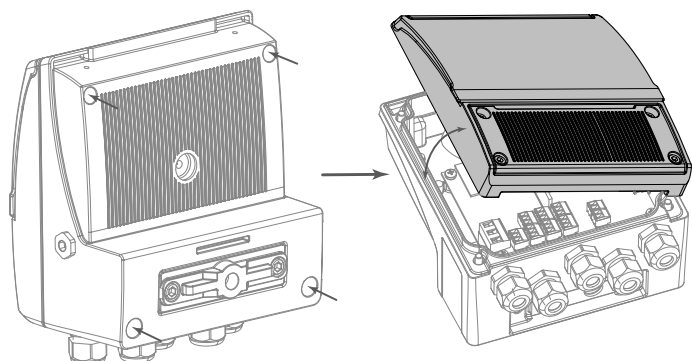

Remove the 4 screws(see "MV110 construction (ALUMINIUM AND PA6 VERSIONS)" to remove the MV110 board. Attention of any electrical cables. Remove the SD card and insert the new MV110 board.

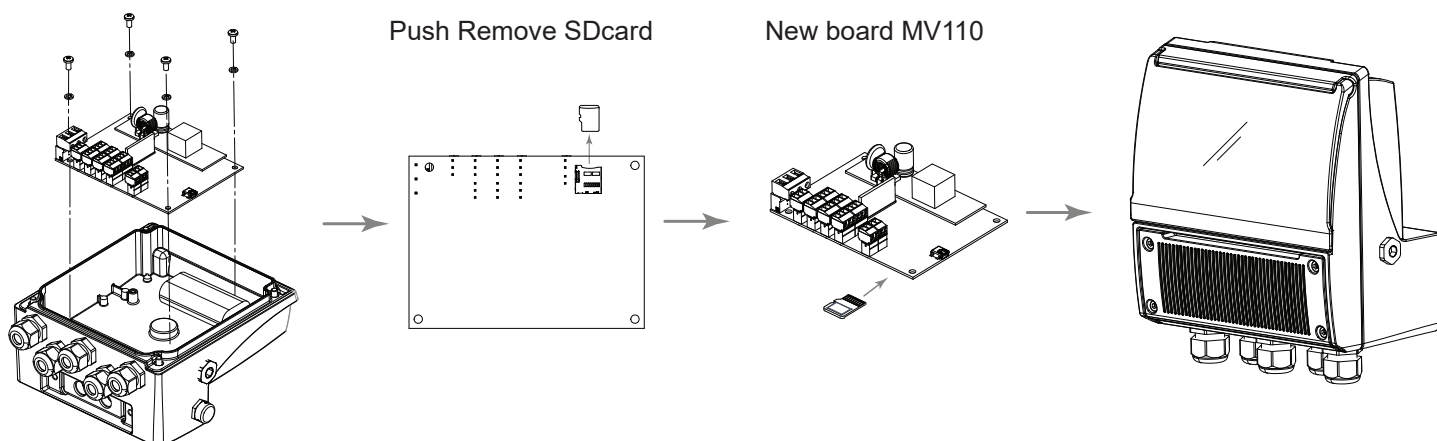

When the board is assembled, turn on the converter and enable [Save Conv. F. def.] function to restore data.

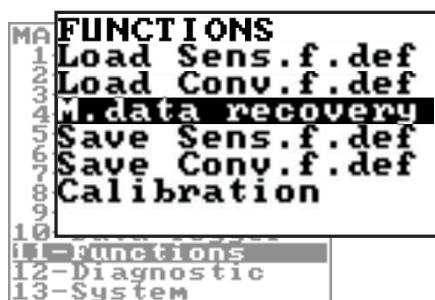

## B.I.V. (BUILT-IN VERIFICATOR)

BIV, abbreviation for Built In Verificator, is available as option for MV110 converters and must be enabled by the manufacturer. It is also necessary that the SD card is activated to store saved data. The analysis of collected data performed by a dedicated IsoBIV software running on another device (PC).

The simplicity of test procedures minimize the risk of handling errors; maximum safety and reliability thanks to the traceable factory calibration and internal references complement the safety by design principle with minimal failure rates. IsoBIV allows to create and print a report as validation of device functionality/measure error.

### Operation and Conditions of Use.

The system is based on periodic measurements performed every hour or using a manual command (MCP command = SVERC). The sensor parameters are measured and compared with previously measured and stored reference values. Each time the system performs a series of measurements on the sensor and records them in a file called "STESTLOG.CSV", which resides in the main directory of the SD memory of the converter.

The sensor test can also be carried out without the active BIV system, but in this case only the presence of isolation losses and the overall good functioning of the sensor such the coil resistance, the excitation current and the rising times of the current within the generic limits that guarantee operation.

Instead if BIV is active, the measurements are deeper and the measured values are tested by comparing them with a set of characteristic sensor parameters measured at the time of installation.

### Saving Reference Values (Characteristic Parameters)

After sensor installation, the parameters that will be used as reference for the BIV system and the IsoBIV data analysis software must to be measured.

The characteristic values of the coil circuits are saved in the converter memory at the factory before to ship the instrument. For the reference measure of the electrodes circuits, there is a specific function that perform the measures of voltage and resistance at the installation site. This function is managed ONLY by the IsoBIV program, which through a simple wizard will set the converter to perform the measures in the specific measurement point where the meter is installed.

To activate BIV, these functions must be verified:

- [ASVFE=1]** : It enable the sensor's automatic test every hour. The ASVFE function in Menu 1 with access level 3 can be also activated using the instrument's display.

This feature can be enabled even if the SD card is not installed and if the BIV function is not active; in such a case the sensor file is NOT created and any alarms will be generated either if the data deviation from the reference data is outside the sensor's limits.

Practically, in the absence of the necessary hardware permissions, this function is useful to test the insulation of the coils.

## Opening and reading manually the files STESTLOG.CSV

The list below describes the steps for saving and reading STESTLOG.CSV file.

❑ OPEN INTERFACE STARTING THE PROGRAM MCP



❑ FOLLOW THE STEPS HERE BELOW

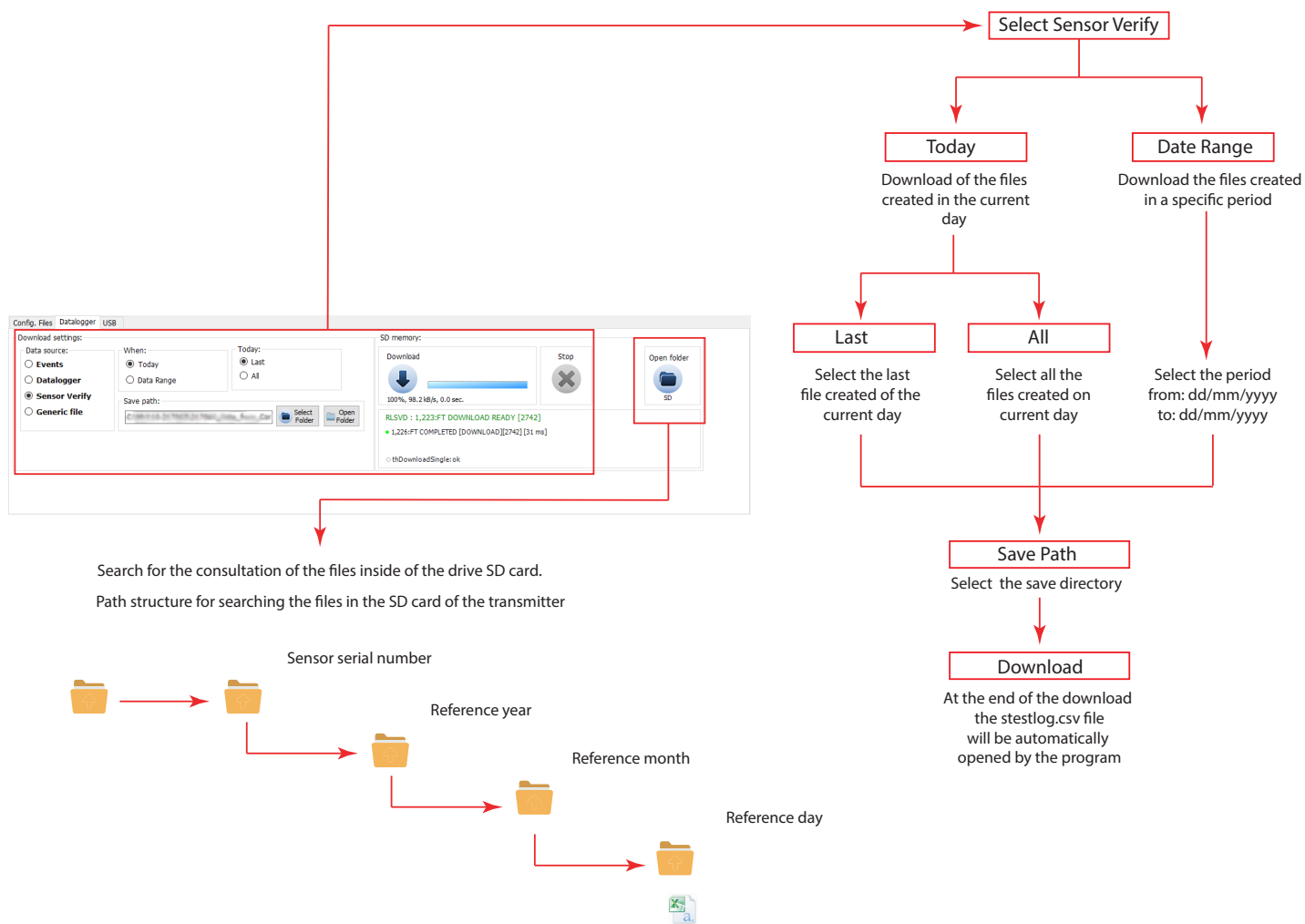

The manufacturer guarantees only English text available on our web site: www.isoil.com

□ READING AND MEANING OF FILE STESTLOG.CSV



A	Registration Number
B	Data
C	Hour
D	Error code in hexadecimal format (0 = no error)
E	The temperature unit (degrees F or C) (#) (*)
F	CPU temperature
G	The unit of voltage CPU (V) (#)
H	Voltage measured on the electrode E1
I	The unit of voltage E1 (V) (#)
J	Reference voltage electrode E2
K	The unit of voltage E2 (V) (#)
L	Differential voltage E1-E2
M	The unit of voltage (V) (#)
N	Common mode voltage (E1 + E2) / 2
O	The unit of resistance (ohm) (#)
P	Resistance measured between E1 and the common
Q	The unit of resistance (ohm) (#)
R	Resistance measured between E2 and the common
S	The unit of voltage (V) (#)
T	Common mode noise at low frequency
U	The unit of voltage (V) (#)
V	Differential mode noise at low frequency
W	The unit of voltage (mV) (#)
X	Mode ADC noise at low frequency differential
Y	The unit of voltage (mV) (#)
Z	Mode ADC noise high frequency differential
AA	The unit of voltage (V) (#)
AB	Analog circuitry positive supply voltage
AC	The unit of voltage (V) (#)
AD	Negative supply voltage analog circuits
AE	The unit of current (mA) (#)
AF	Excitation current of the coils
AG	The unit of resistance (ohm) (#)
AH	Measurement of the sensor coil resistance
AI	The temperature unit (degrees F or C) (#) (*)
AJ	Temperature of the sensor coils
AK	The unit of current (mA) (#)
AL	The coil leakage current (insulation fault)
AM	Unit of measure of time (ms) (#)
AN	Rise time current phase A
AO	Unit of measure of time (ms) (#)
AP	Rise time current phase B

**NOTE:**

(#): The units are registered only if the appropriate function of the DATA LOGGER is active. Otherwise the field is empty.

(\*): The temperature values can be expressed in degrees F or C, depending on the drive configuration

## Standard and internal check to the instrument limits

The measured data are compared with the reference values previously stored. The variation of different variable measured, shall be within the following range:

- ❑ Coil temperature (using resistance reading): within limits compatible with the lining material
- ❑ Current up times: change% detected resistance coils + 10% (tolerance range)
- ❑ Resistance between electrodes and common: between 0.3 and 3.0 times the reference early strength
- ❑ Leakage current (insulation test): less than 0.1 mA

If the values deviate beyond these limits it is generated and displayed a coded alarm.

The alarm remains active and visible on the display until next test (max. 1 hour).

## SOFTWARE ISOBIV

The IsoBiv software allows analysis and processing of STESTLOG.CSV file data.

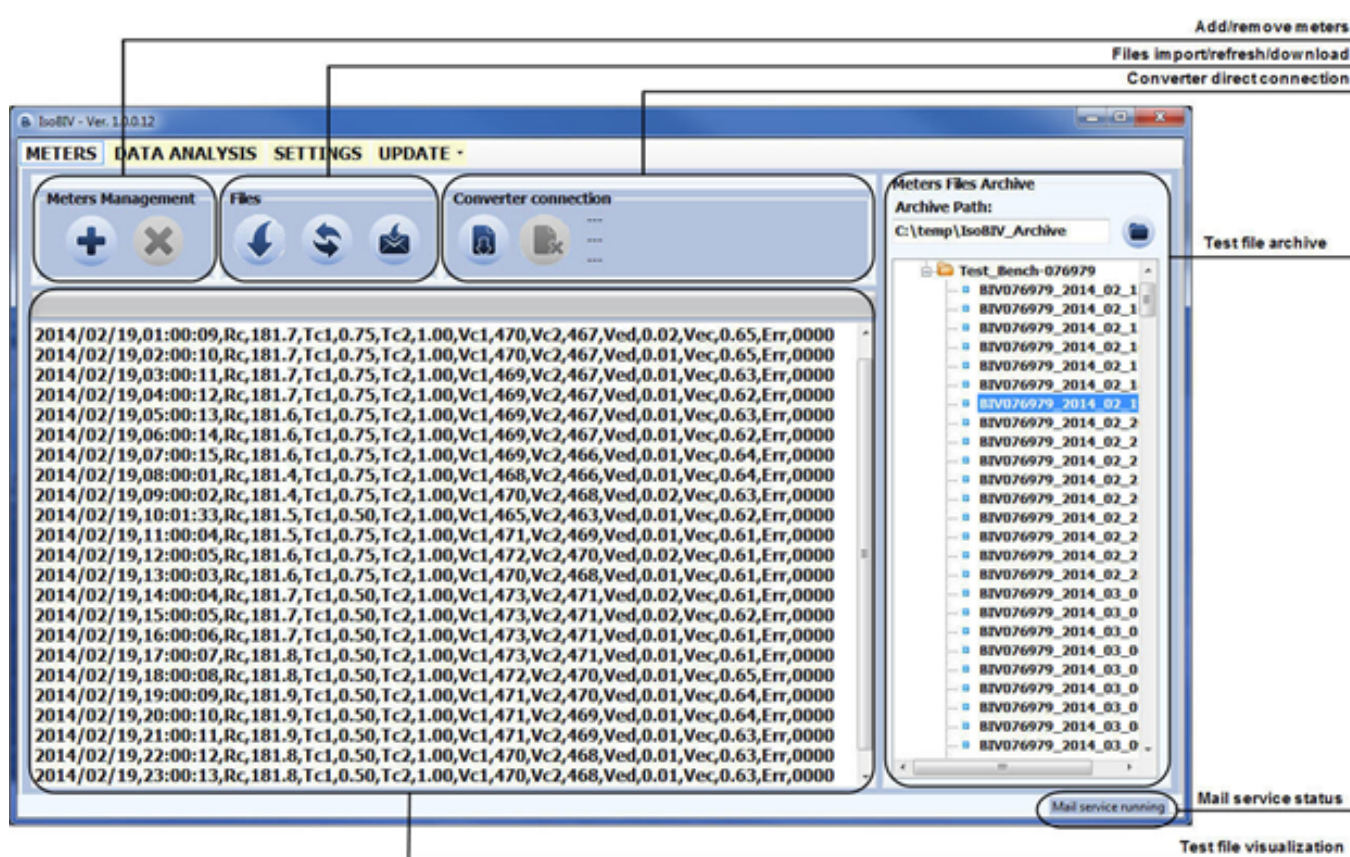

For further information, refer to the manual of ISOBIV software.

## ALARM MESSAGES (CAUSES AND ACTIONS TO BE TAKEN)

MESSAGE	CAUSES	ACTION TO TAKE
NO ALARMS	All works regularly	---
[000] SYSTEM RESTART	---	---
[001] INTERNAL PS FAIL	Internal supply voltage error	Contact the service
[002] CLOCK NOT SET	System Clock not set	Set the system clock from the converter menu 13 (see also MCP function ).
[003] SD CARD FAILURE	SD card not found or unreadable	check and/or replace SD card
[005] F-RAM ERROR	Error writing / reading Flash-RAM	Contact the service
[006] EXCITATION ERROR	The excitation of the sensor coils resulting from cable is interrupted	Check the connecting cables to the sensor.
[007] SIGNAL ERROR	The measure is strongly effected by external noise or the cable connecting the converter to the sensor is broken.	Check the status of the cables connecting the sensor, the grounding connections of the devices and the possible presence of noise sources.
[008] PIPE EMPTY	The measuring pipe is empty or the detection system has not been properly calibrated.	Check whether the pipe is empty or repeat the empty pipe calibration procedure.
[009] FLOW>MAX+	The flow rate is higher than the maximum positive threshold set.	Check the maximum positive flow rate threshold set and the process conditions.
[010] FLOW>MAX-	The flow rate is higher than the maximum negative threshold set.	Check the maximum negative flow rate threshold set and the process conditions.
[011] FLOW<MIN+	The flow rate is lower than the minimum positive threshold set.	Check the minimum positive flow rate threshold set and the process conditions.
[012] FLOW<MIN-	The flow rate is lower than the minimum negative threshold set.	Check the minimum negative flow rate threshold set and the process conditions.
[013] FLOW>FULL SCALE+	The flow rate is higher than the full scale positive value set on the instrument.	Check the full scale positive value set on the instrument and the process conditions.
[014] FLOW>FULL SCALE-	The flow rate is higher than the full scale negative value set on the instrument.	Check the full scale negative value set on the instrument and the process conditions.
[015] PULSE1>RANGE	The pulse generation output 1 of the device is saturated and cannot generate the sufficient number of impulses.	Set a bigger unit of volume or, if the connected counting device allows it, reduce the pulse duration value.
[016] PULSE2>RANGE	The pulse generation output 2 of the device is saturated and cannot generate the sufficient number of impulses.	Set a bigger unit of volume or, if the connected counting device allows it, reduce the pulse duration value.
[017] CALIBR.ERROR	Calibration Error	Contact the service
[018] SYSTEM FREQ. ERR	System Freq. Error	Contact the service
[019] B.DATA NOT INIT	Uninitialized data system	Contact the service
[020] FL.SENSOR ERROR	Flow rate sensor error	Contact the service
[021] BATTERY LOW	(Rechargeable) battery depleted	Contact the service to Replace the battery
[022] BATTERY V>MAX	Battery voltage (rechargeable)> max. Allowed	Contact the service to Replace the battery
[023] BATTERY I>MAX	Battery charge current> max. allowed	Contact the service to Replace the battery
[024] MAIN PS V.ERR	Main supply voltage (+ 5V) out of tolerance.	Contact the service

[025] USB VOLTAGE ERR	Voltage of USB connection out of tolerance.	Contact the service
[026] SDC ALMOST FULL	SD card space <500 MB.	For more information see function "12.9" page37.
[027] SDC FULL	SD card out of memory	Memory Full. You can not save logger. Contact the service to replace the SD memory.
[028] BATT.TEMP.CRIT	The battery can not be charged. The temperature is out of range ( detected temperature <0 C° or temperature >50°)	Wait for the normal temperature reset. See Environmental Use Conditions "Environmental Use Conditions" page5.
[032] SYS.PROT.FAULT	MID verification fault.	Contact the service
[033] ISOCALMASTER DETECTED	IsocalMaster module installed	—

## ERROR CODE TEST SYSTEM OF SENSOR

The codes are in hexadecimal format, the meaning is given for each bit. There are several possible error simultaneous combinations (more bits active) then that will give the combined numerical codes.

CODE	ANOMALIES DESCRIPTION	ACTION TO TAKE
0000	NO ERROR	---
0001	SENSOR TEST INSULATION: Generator power too low	Contact the service
0002	SENSOR TEST INSULATION: Generator power too high	
0004	SENSOR TEST INSULATION: Phase 1 generator voltage too low	
0008	SENSOR TEST INSULATION: Phase 1 generator voltage too high	
0010	SENSOR TEST INSULATION: Phase 1 terminal voltage coils 1 too low	
0020	SENSOR TEST INSULATION: Phase 1 terminal voltage coils 2 too low	
0040	SENSOR TEST INSULATION: Phase 2 generator voltage too low	
0080	SENSOR TEST INSULATION: Phase 2 generator voltage too high	
0100	SENSOR TEST INSULATION: Phase 2 terminal voltage coils 1 too low	
0200	SENSOR TEST INSULATION: Phase 2 terminal voltage coils 2 too low	
0400	SENSOR TEST INSULATION: Insulation loss, leakage current out of tolerance	
0800	TEST TEMPERATURE (RESISTANCE) COILS: Temperature (resistance) out of tolerance	
1000	TEST TIME GETTING ON CURRENT PHASE (A): Value out of tolerance	
2000	TEST TIME GETTING ON CURRENT PHASE (B): Value out of tolerance	
4000	TEST RESISTANCE INPUTS ELECTRODES: Input value 1 out of tolerance	
8000	TEST RESISTANCE INPUTS ELECTRODES: Input value 2 out of tolerance	Contact the service
10000	SENSOR EXCITATION TEST: Invalid sensor driving conditions	
20000	REFERENCE VALUES TEST: Invalid reference values	
40000	ELECTRODES INPUT RESISTANCE TEST: Empty pipe, test not possible	

The manufacturer guarantees only English text available on our web site [www.isoil.com](http://www.isoil.com)

At the end of its lifetime, this product shall be disposed of in full compliance with the environmental regulations of the state in which it is located.

## MANUAL REVIEWS

REVIEW	DATE	DESCRIPTION
110_EN_IT_R0_1.00.0	15/09/2016	First edition
110_EN_IT_R1_1.00.0	6/02/2017	Insert meter BIV interface
110_EN_IT_R2_1.00.0	09/03/2017	Inserted logos HART certification
110_EN_IT_R3_1.00.0	21/06/2017	Updated the layout
110_EN_IT_R4_1.00.0	08/03/2019	Function description alignment
110_EN_IT_R5_1.00.0	27/03/2019	Internal lithium battery information added
110_EN_IT_R6_1.00.0	12/04/2019	Updated the data in the Modbus command table 8
110_EN_IT_R7_1.00.0	16/03/2020	Error codes test system of sensor added
110_EN_IT_R8_1.00.0	12/06/2020	MODbus notes implementation
110_EN_IT_R9_1.02.0	17/07/2020	Software update
MAN_MV110_EN_IT_IS_R10_1.02.0	15/03/2021	Added stainless steel case option, added meter data technical specifications, changes to the function description list, correction of Tpls 1-2 value range
MAN_MV110_EN_IT_IS_R11_1.04.XXXX	16/08/2021	Graphics and nomenclature update. Update for electrical safety certification. Firmware update for adding Mbus protocol (separate manual)
MAN_MV110_EN_IT_IS_R12_1.04.XXXX	07/10/2021	Changes to data relating to digital output
MAN_MV110_EN_IT_IS_R13_1.04.XXXX	20/12/2021	Correction of grammatical errors and description of 1.16 and 1.17 functions
MAN_MV110_EN_IT_IS_R14_1.04.XXXX	02/02/2022	Changes on alarms table
MAN_MV110_EN_IT_IS_R15_1.04.XXXX	19/05/2022	Changes on menu alarms
MAN_MV110_EN_IT_IS_R16_1.04.XXXX	18/10/2022	Corrections on download datalogger table
MAN_MV110_EN_IT_IS_R17_1.04.XXXX	18/01/2023	Corrections on some functions description
MAN_MV110_EN_IT_IS_R18_1.05.XXXX	16/02/2023	Update visualitation pages
MAN_MV110_EN_IT_IS_R19_1.05.XXXX	15/06/2023	Added measurement tolerance

## ISOIL INDUSTRIA S.p.A.

HEAD OFFICE	SERVICE
Via Fratelli Gracchi, 27 20092 Cinisello Balsamo (MI) Tel +39 02 66027.1 sales@isoil.it	service@isoil.it

If you want to find the complete list of our distributors access at the following link:  
<http://www.isoil.it/en>



Due to the constant technical development and improvement of its products, the manufacturer reserves the right to make changes and/or modify the information contained in this document without notice.